

Caratteristiche - Specifications - Caractéristiques - Características

IN	Ø	3/4 BSP
	Press. Min.	-0,1 bar (-1.5 PSI)
	Press. Max.	6 bar (87 PSI)
	Temp. Max.	74°C (165°F)
OUT	Ø	3/8 BSP
SHAFT	Ø	24 mm
OIL	SAE 75W 90	1,3l (0.34 U.S.gal.)
WEIGHT	kg (lbs)	15,7 kg (34.5 lbs)

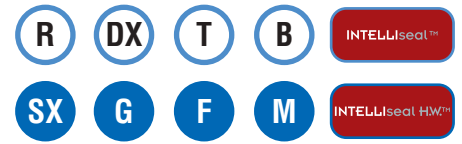

Carter simmetrico con doppio fissaggio per conversione rapida dell'uscita albero (destra o sinistra).  
Symmetrical crankcase with double fixing for quick conversion of the shaft drive (right or left).

Codice Code	Modello Model	Press. Max Max Pressure		950 RPM				1450 RPM				1725 RPM				Pistone Plunger Ø mm	Corsa Stroke mm
		bar	PSI	l/min	GPM	kW	hp	l/min	GPM	kW	hp	l/min	GPM	kW	hp		
06.2066.97.GU	<b>TTK 2130</b>	300	4350	14	3,7	8,1	10,9	21	5,5	12,3	16,4	25	6,6	14,4	19,4	20	16,4
06.2067.97.GU	<b>TTK 2521</b>	210	3045	17	4,5	6,9	9,2	25	6,6	10,4	13,9	30	7,9	12,2	16,4	22	16,4
06.2068.97.GU	<b>TTK 3021</b>	210	3045	19	5,0	8,0	10,7	29	7,7	12,0	16,1	-	-	-	-	22	19

TTK

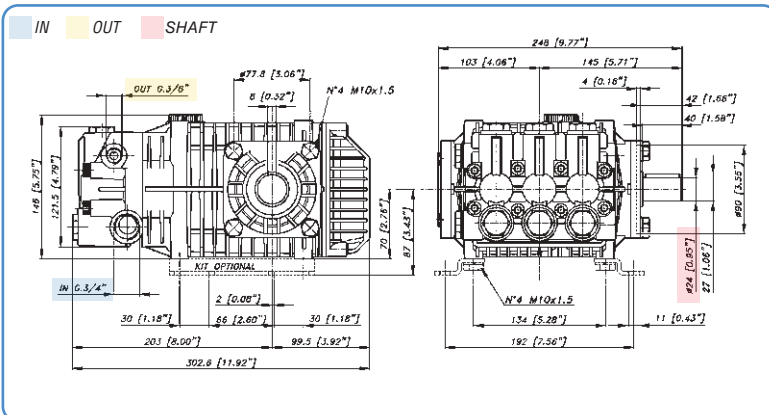

Guarnizioni - Seals  
Joints - Juntas

Anteriori - Front	Super "U"
Posteriori - Rear	"U"



GRAFICO PRESTAZIONI - PERFORMANCE CHART

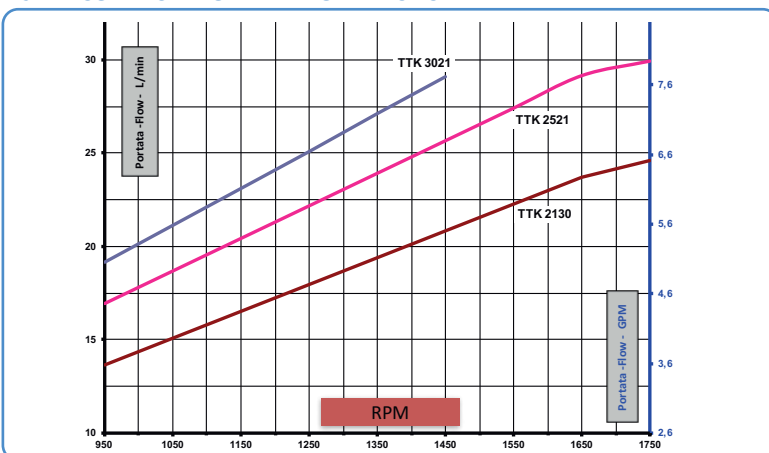

Accessori di completamento - Complementary accessories  
Accessoires complémentaires - Accesorios complementarios

