

Caratteristiche - Specifications - Caractéristiques - Características

IN	Ø	1/2 BSP
	Press. Min.	1 bar (15 PSI)
	Press. Max.	6 bar (87 PSI)
	Temp. Max.	60°C (140°F)
OUT	Ø	3/8 BSP
SHAFT	Ø	Hollow 1"
OIL	SAE 75W 90	0,7l (0.18 U.S.gal.)
WEIGHT	kg (lbs)	10,8 kg (23.7 lbs)
ENGINE	Type	SAE J609-1"



		3450 RPM								
Codice Code	Modello Model	Press. Max Max Pres.		Portata Flow		Potenza Power			Pistone Plunger	Corsa Stroke
		bar	PSI	l/min	GPM	kW	hp	hp Engine	Ø mm	mm
07.1600.97.A	TMG 3535	240	3500	13	3,4	6,3	8,5	11	15	8,6
07.1601.97.A	TMG 4035	280	4000	13	3,4	7	9,5	13	15	8,6
07.1602.97.A	TMG 3540	240	3500	15	4,0	7	9,6	13	15	9,8
07.1603.97.A	TMG 4040	280	4000	15	4,0	8,1	11	14,5	15	9,8
07.1604.97.A	TMG 3545	240	3500	17	4,5	6	8,1	14	15	11,2
07.1605.97.A	TMG 4045	280	4000	17	4,5	9,2	12,5	16	15	11,2
07.1606.97.A	TMG 3550	240	3500	19	5,0	8,8	12	16	15	12,4
07.1607.97.A	TMG 4050	280	4000	19	5,0	9,9	13,5	18	15	12,4
07.1608.97.A	TMG 3555	240	3500	21	5,5	9,9	13,5	18	15	14

Guarnizioni - Seals
Joints - Juntas

Anteriori - Front	"V"
Posteriori - Rear	"U"

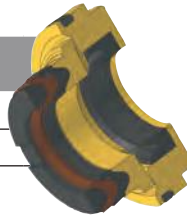

TMG 1"

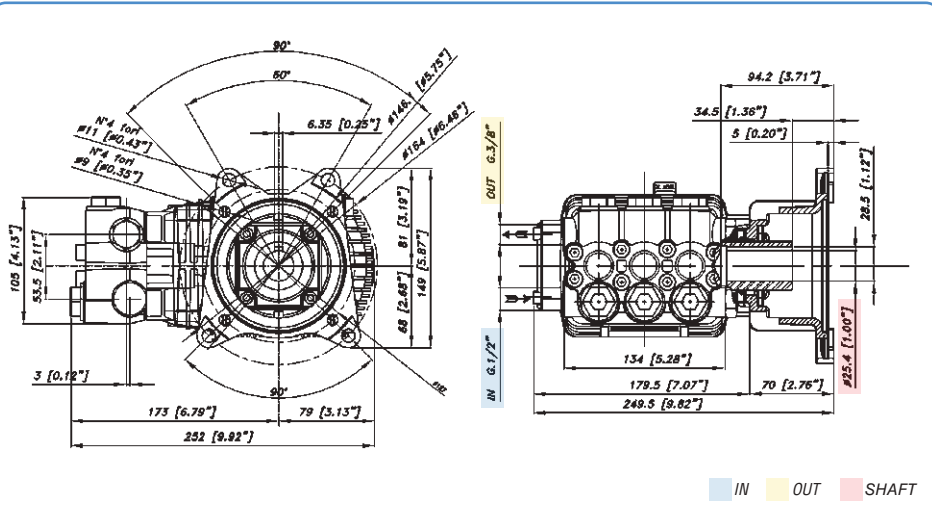

Accessori di completamento - Complementary accessories
Accessoires complémentaires - Accesorios complementarios



pag.115