

TAM 316

SERIES 316

Caratteristiche - Specifications - Caractéristiques - Características

IN	Ø	1/2 BSP
	Press. Min.	-0,1 bar (-1.5 PSI)
	Press. Max.	6 bar (87 PSI)
	Temp. Max.	85°C (185°F)
OUT	Ø	3/8 BSP
SHAFT	Ø	24 mm
OIL	SAE 75W 90	0,71 (0.18 U.S.gal.)
WEIGHT	kg (lbs)	10,6 kg (23.3 lbs)



Codice Code	Modello Model	Press. Max Max Pressure		950 RPM				1450 RPM				1725 RPM				Pistone Plunger	Corsa Stroke
		bar	PSI	l/min	GPM	KW	hp	l/min	GPM	KW	hp	l/min	GPM	KW	hp		
07.1018.97.A	TAM 1215	150	2175	8	2,1	2,3	3,1	12	3,2	3,4	4,6	14	3,7	4,0	5,4	18	11,2
07.1024.97.A	TAM 1315	150	2175	9	2,4	2,5	3,4	13	3,4	3,8	5,1	15	4,0	4,5	6,0	18	12,4
07.1025.97.A	TAM 1515	150	2175	10	2,6	2,9	3,9	15	4,0	4,4	5,9	18	4,8	5,2	7,0	18	14,4
07.1026.97.A	TAM 1715	150	2175	11	2,9	3,2	4,3	17	4,5	4,9	6,6	20	5,3	5,8	7,8	18	16
07.1027.97.A	TAM 2015	150	2175	13	3,4	3,8	5,1	20	5,3	5,7	7,6	23	6,1	6,7	9,0	18	18,7

TAM 316

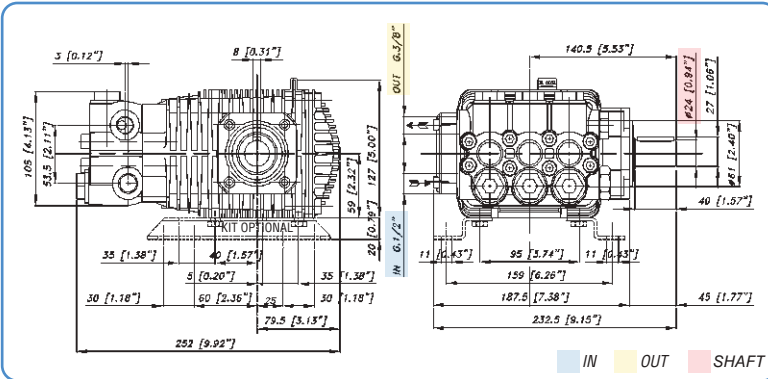

Guarnizioni - Seals
Joints - Juntas

Anteriori - Front Super "U"
Posteriori - Rear "U" PTFE - 85°C (185°F)



GRAFICO PRESTAZIONI - PERFORMANCE CHART



Accessori di completamento - Complementary accessories
Accessoires complémentaires - Accesorios complementarios

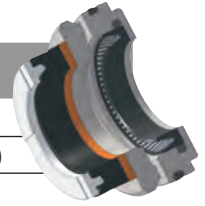
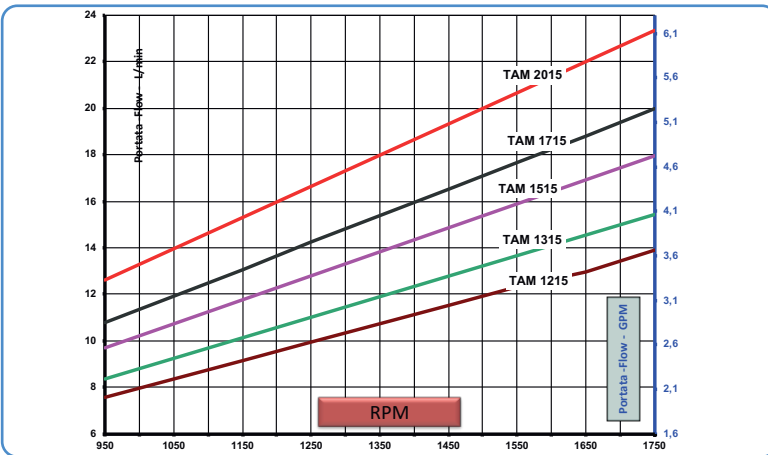