

Caratteristiche - Specifications - Caractéristiques - Características

IN	Ø	1" BSP
	Press. Min.	-0,1 bar (-1.5 PSI)
	Press. Max.	6 bar (87 PSI)
	Temp. Max.	74°C (165°F)
OUT	Ø	1/2 BSP
SHAFT	Ø	30 mm
OIL	SAE 75W 90	1,5l (0.4 U.S.gal.)
WEIGHT	kg (lbs)	23 kg (50.7 lbs)

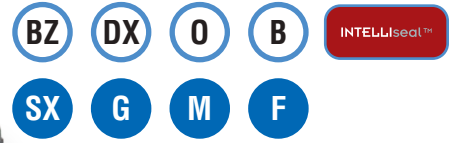

Codice Code	Modello Model	Press. Max Max Pressure		950 RPM				1200 RPM				1450 RPM				Pistone Plunger	Corsa Stroke
		bar	PSI	l/min	GPM	kW	hp	l/min	GPM	kW	hp	l/min	GPM	kW	hp		
08.1086.97.3	RD 6315	150	2175	41	10,8	12,1	16,2	51	13,5	15,1	20,2	61	16,1	18,1	24,2	30	21
08.1085.97.3	RD 7515	150	2175	49	12,9	14,4	19,3	61	16,1	18,0	24,1	73	19,3	21,5	28,8	30	25

RD

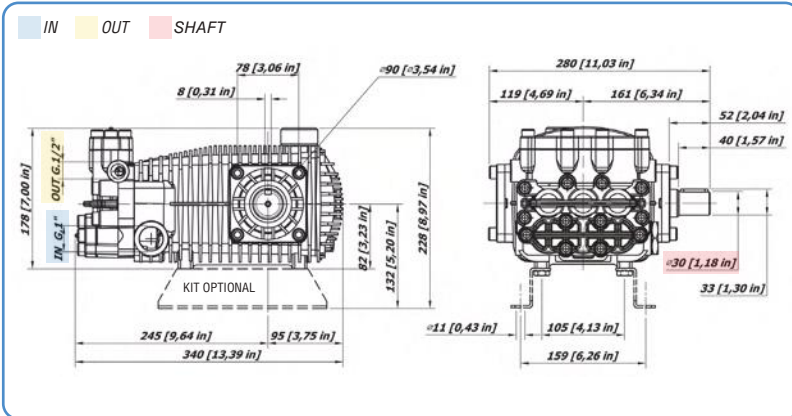

Guarnizioni - Seals
Joints - Juntas

Anteriori - Front Super "U"
Posteriori - Rear "U"

GRAFICO PRESTAZIONI - PERFORMANCE CHART

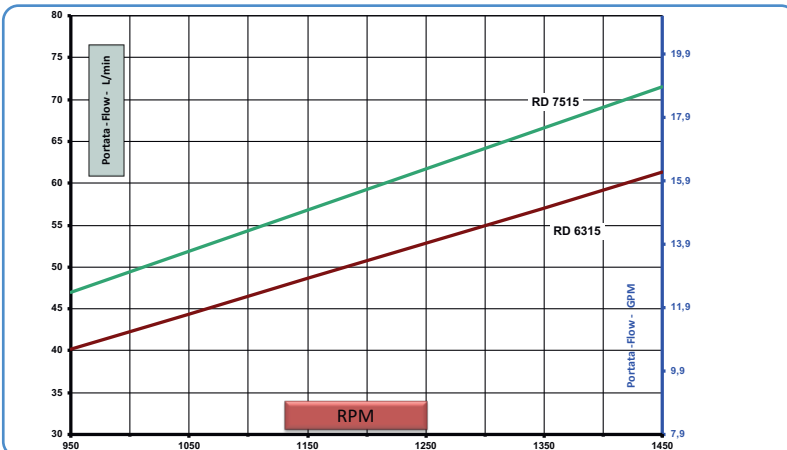

Accessori di completamento - Complementary accessories
Accessoires complémentaires - Accesorios complementarios

