

COMPACT Series

C 40.1

40.5 l/m
10.7 USGPM

max 50 BAR
725 P.S.I.

APPLICAZIONI - APPLICATIONS



ATOMIZZATORI
ATOMIZERS



CLEANING
CLEANING



NEBULIZZAZIONE
SPRAYING

SPECIAL TRADEMARK

El EASYlube™

Sc SMARTcase™

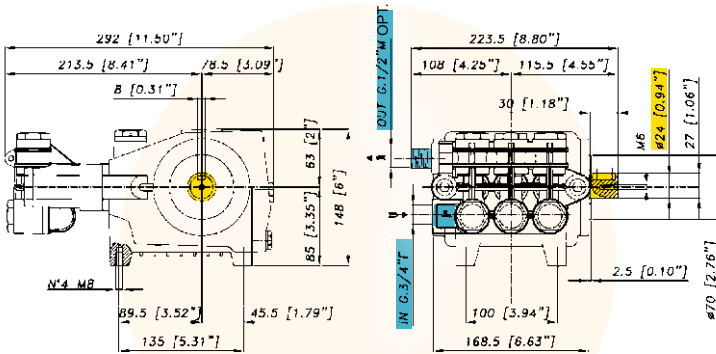

P

CARATTERISTICHE TECNICHE SPECIFICATIONS	1450 g/min. 1450 R.P.M.	
Potenza - Power	3,8 KW	5.1 HP
Peso - Weight	12 Kg	24,6 lb
IN	G 1/2	
Pressione Min - Min Pressure	-0,15 BAR	- 2.17 P.S.I.
	-0,3 BAR (servizio discontinuo)	-0.435 P.S.I. (discontinuous service)
Pressione Max - Max Pressure	1 BAR	14.5 P.S.I.
OUT	G 1/2	
Max. Temperatura - Max. Temperature	60 °C	140 °F
Tipo olio - Oil type	SAE 30	
Capacità olio - Oil capacity	0,95 lt	0.25 U.S.G.

TABELLA RENDIMENTI PERFORMANCE CHART								
g/min R.P.M.	800		1000		1200		1450	
BAR P.S.I.	L/min USGPM	KW HP	L/min USGPM	KW HP	L/min USGPM	KW HP	L/min USGPM	KW HP
2 29	22,3 5,9	0,1 0,1	27,9 7,4	0,1 0,1	33,5 8,9	0,1 0,2	40,5 10,7	0,2 0,2
20 290	22,1 5,8	1,3 1,7	27,6 7,3	1,6 2,2	33,1 8,7	2,0 2,6	40,0 10,6	2,4 3,1
40 580	21,8 5,8	1,7 2,3	27,2 7,2	2,1 2,9	32,7 8,6	2,6 3,4	39,5 10,4	3,1 4,1
50 725	21,5 5,7	2,1 2,8	26,9 7,1	2,6 3,5	32,3 8,5	3,2 4,2	39,0 10,3	3,8 5,1

Versioni Versions

38.9906.97.3



COMPACT Series

C 53.3

50.6 l/m
13.4 USGPM

max 50 BAR
725 P.S.I.

APPLICAZIONI - APPLICATIONS

ATOMIZZATORI
ATOMIZERS

CLEANING
CLEANING

NEBULIZZAZIONE
SPRAYING

SPECIAL TRADEMARK

EL EASYlube™

SCs SUPERCOOLINGsystem™

Sc SMARTcase™

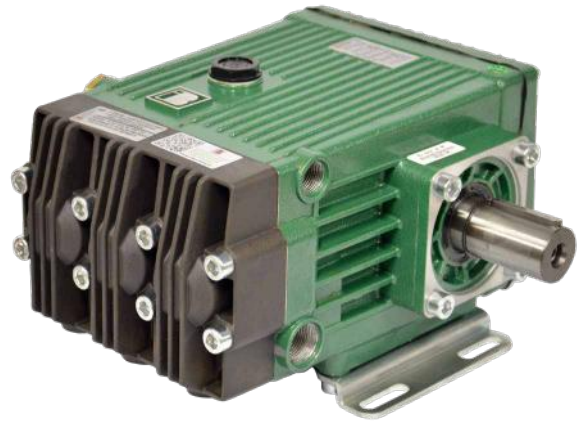
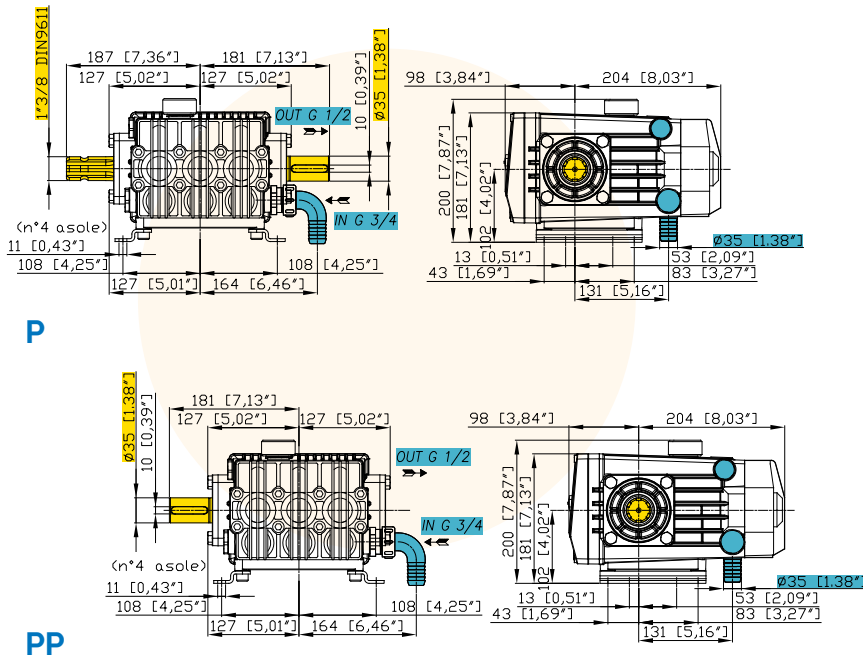

CARATTERISTICHE TECNICHE SPECIFICATIONS

550 g/min.
550 R.P.M.

Potenza - Power	4,9 KW	6.6 HP
Peso - Weight	20 Kg	44 lb
IN	25 mm	1" in
Pressione Min - Min Pressure	-0,15 BAR	- 2.17 P.S.I.
	-0,3 BAR (servizio discontinuo)	-0.435 P.S.I. (discontinuous service)
Pressione Max - Max Pressure	1 BAR	14.5 P.S.I.
OUT	G 1/2	
Max. Temperatura - Max. Temperature	60 °C	140 °F
Tipo olio - Oil type	SAE 30	
Capacità olio - Oil capacity	1,9 lt	0.5 U.S.G.

TABELLA RENDIMENTI PERFORMANCE CHART

g/min R.P.M.	400		450		500		550	
	BAR P.S.I.	L/min USGPM	KW HP	L/min USGPM	KW HP	L/min USGPM	KW HP	L/min USGPM
2 29	36,8	0,1	41,4	0,1	46,0	0,1	50,6	0,2
	9,7	0,2	10,9	0,2	12,2	0,2	13,4	0,3
30 435	36,7	2,2	41,2	2,4	45,8	2,7	50,4	3,0
	9,7	2,9	10,9	3,2	12,1	3,6	13,3	4,0
40 580	36,5	2,9	41,1	3,2	45,6	3,6	50,2	3,9
	9,6	3,8	10,9	4,3	12,1	4,8	13,3	5,3
50 725	36,4	3,6	40,9	4,0	45,5	4,5	50,0	4,9
	9,6	4,8	10,8	5,4	12,0	6,0	13,2	6,6

Versioni Versions

53.6000.97.A - P

53.6004.97.A - PP



Destro/Right

Sinistro/Left

Sinistro/Left

COMPACT Series

C 75.1

67 L/m
17.4 USGPM

max 50 BAR
725 P.S.I.

APPLICAZIONI - APPLICATIONS

ATOMIZZATORI
ATOMIZERS

CLEANING
CLEANING

SPECIAL TRADEMARK

EL EASYlube™

SCs SUPERCOOLINGsystem™

Sc SMARTcase™

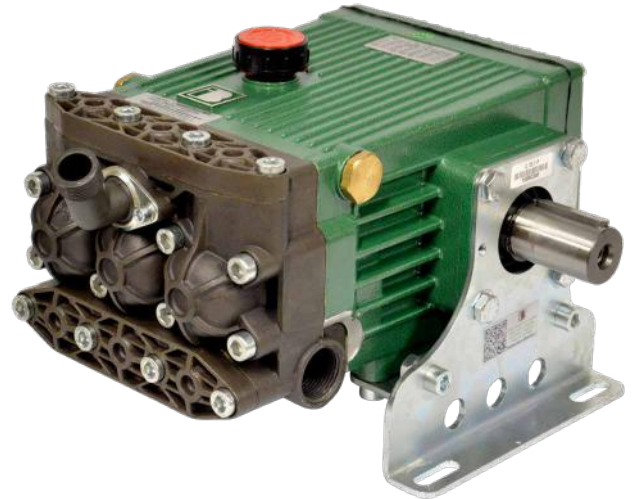
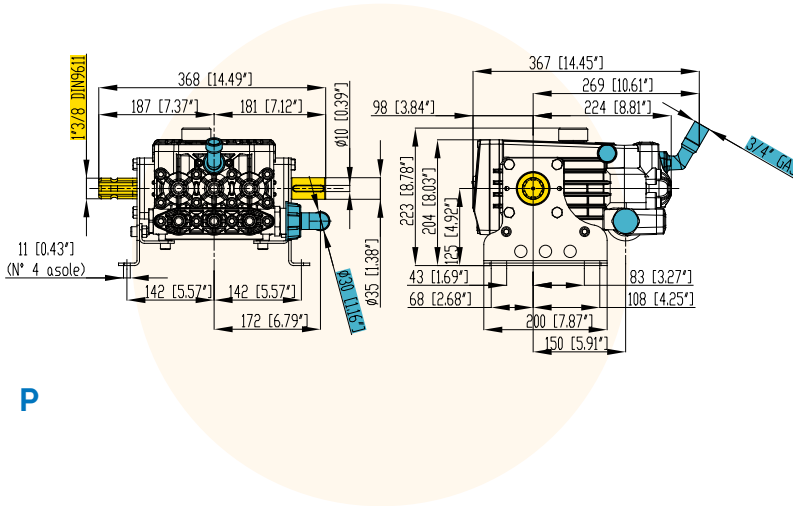

CARATTERISTICHE TECNICHE SPECIFICATIONS	550 g/min. 550 R.P.M.	
Potenza - Power	6,3 KW	8.4 HP
Peso - Weight	21 Kg	46.2 lb
IN	30 mm	1"3/16 in
Pressione Min - Min Pressure	-0,15 BAR	- 2.17 P.S.I.
	-0,3 BAR (servizio discontinuo)	-0.435 P.S.I. (discontinuous service)
Pressione Max - Max Pressure	1 BAR	14.5 P.S.I.
OUT	G 3/4	
Max. Temperatura - Max. Temperature	60 °C	140 °F
Tipo olio - Oil type	SAE 30	
Capacità olio - Oil capacity	2 lt	0.53 U.S.G.

TABELLA RENDIMENTI PERFORMANCE CHART								
g/min R.P.M.	400		450		500		550	
BAR P.S.I.	L/min USGPM	KW HP	L/min USGPM	KW HP	L/min USGPM	KW HP	L/min USGPM	KW HP
2 29	48,7 12,9	0,2 0,3	54,8 14,5	0,2 0,3	60,9 16,1	0,2 0,3	67,0 17,7	0,3 0,4
30 435	48,0 12,7	2,8 3,8	54,0 14,3	3,2 4,3	60,0 15,9	3,5 4,7	66,0 17,4	3,9 5,2
40 580	47,3 12,5	3,7 5,0	53,2 14,1	4,2 5,6	59,1 15,6	4,6 6,2	65,0 17,2	5,1 6,8
50 725	46,5 12,3	4,6 6,1	52,4 13,8	5,1 6,9	58,2 15,4	5,7 7,6	64,0 16,9	6,3 8,4

Versioni Versions

53.6000.97.A - P

53.6004.97.A - PP



Destro/Right

Sinistro/Left

Sinistro/Left

COMPACT Series

CK 73.1

72 L/m
19 USGPM

max 70 BAR
1015 P.S.I.

APPLICAZIONI - APPLICATIONS

 ATOMIZZATORI
ATOMIZERS

 CLEANING
CLEANING

SPECIAL TRADEMARK

 EL EASYlube™

 IS INTELLiseal™

 Sc SMARTcase™

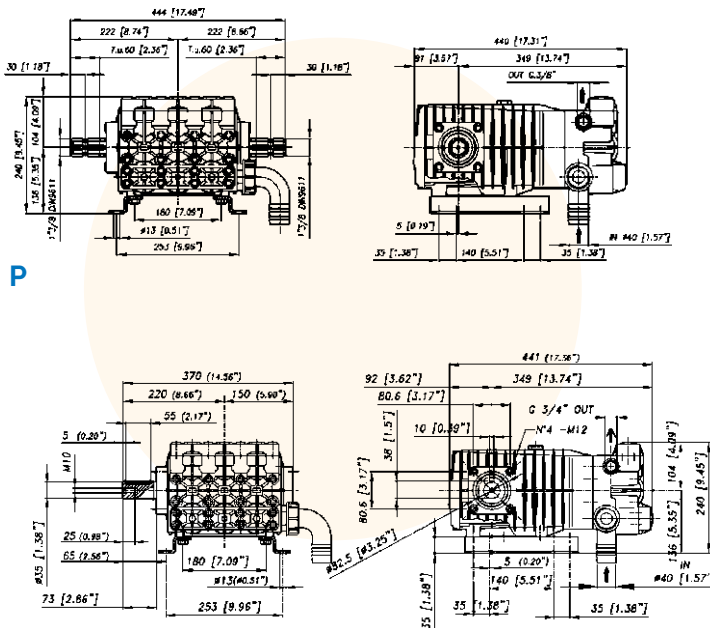

PP

CARATTERISTICHE TECNICHE SPECIFICATIONS	550 g/min. 550 R.P.M.	
Potenza - Power	9,6 KW	12.9 HP
Peso - Weight	32 Kg	70.4 lb
IN	40 mm	1"9/16 in
Pressione Min - Min Pressure	-0,15 BAR	- 2.17 P.S.I.
	-0,3 BAR (servizio discontinuo)	-0.435 P.S.I. (discontinuous service)
Pressione Max - Max Pressure	1 BAR	14.5 P.S.I.
OUT	G 3/4 mm	
Max. Temperatura - Max. Temperature	60 °C	140 °F
Tipo olio - Oil type	SAE 30	
Capacità olio - Oil capacity	2,8 lt	0.74 U.S.G.

TABELLA RENDIMENTI PERFORMANCE CHART								
g/min R.P.M.	400		450		500		550	
BAR P.S.I.	L/min USGPM	KW HP	L/min USGPM	KW HP	L/min USGPM	KW HP	L/min USGPM	KW HP
2 29	52,4 13,8	0,2 0,3	58,9 15,6	0,2 0,3	65,5 17,3	0,2 0,3	72,0 19,0	0,3 0,4
30 435	51,3 13,5	3,0 4,0	57,7 15,2	3,4 4,5	64,1 16,9	3,8 5,0	70,5 18,6	4,2 5,5
50 725	52,0 13,7	5,1 6,8	58,5 15,5	5,7 7,7	65,0 17,2	6,4 8,5	71,5 18,9	7,0 9,4
70 1015	50,9 13,5	7,0 9,3	57,3 15,1	7,9 10,5	63,6 16,8	8,7 11,7	70,0 18,5	9,6 12,9

Versioni Versions

73.5107.97.A - P

73.5108.97.A - PP



Destro/Right

Sinistro/Left

Sinistro/Left

COMPACT Series

BERTOLINI
pumps

COMPACT Series CK 120.1

115 l/m
30.4 USGPM

max 70 BAR
1015 P.S.I.

APPLICAZIONI - APPLICATIONS

ATOMIZZATORI
ATOMIZERS

CLEANING
CLEANING

SPECIAL TRADEMARK

EL EASYtube™

Is INTELLiseal™

Sc SMARTcase™

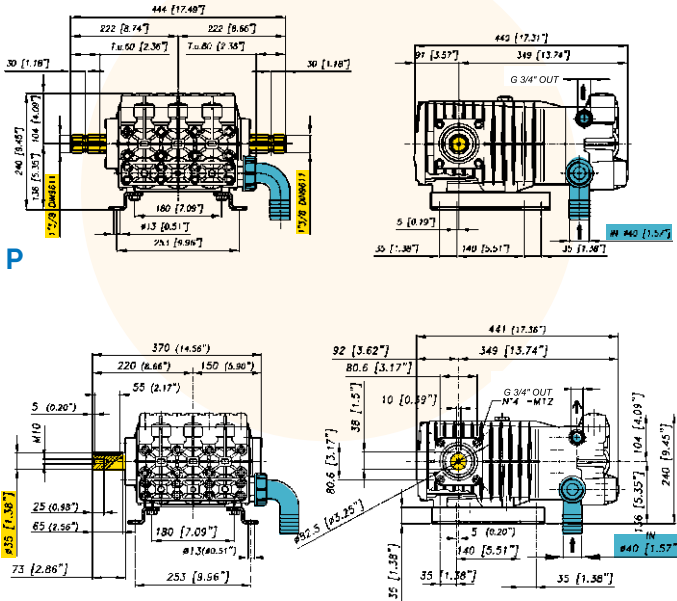

CARATTERISTICHE TECNICHE SPECIFICATIONS	550 g/min. 550 R.P.M.	
Potenza - Power	15,3 KW	20.4 HP
Peso - Weight	33 Kg	72,6 lb
IN	40 mm	1"9/16 in
Pressione Min - Min Pressure	-0,15 BAR	- 2.17 P.S.I.
	-0,3 BAR (servizio discontinuo)	-0.435 P.S.I. (discontinuous service)
Pressione Max - Max Pressure	1 BAR	14.5 P.S.I.
OUT	G 3/4	
Max. Temperatura - Max. Temperature	60 °C	140 °F
Tipo olio - Oil type	SAE 30	
Capacità olio - Oil capacity	2,8 lt	0.74 U.S.G.

TABELLA RENDIMENTI PERFORMANCE CHART								
g/min R.P.M.	400		450		500		550	
BAR P.S.I.	L/min USGPM	KW HP	L/min USGPM	KW HP	L/min USGPM	KW HP	L/min USGPM	KW HP
2 29	83,6 22,1	0,3 0,4	94,1 24,9	0,4 0,5	104,5 27,6	0,4 0,5	115 30,4	0,5 0,6
30 435	82,4 21,8	4,9 6,5	92,7 24,5	5,5 7,3	103 27,2	6,1 8,1	113,3 29,9	6,7 8,9
50 725	81,5 21,5	8,0 10,7	91,6 24,2	9,0 12	101,8 26,9	10,0 13,4	112 29,6	11,0 14,7
70 1015	80,8 21,3	11,1 14,8	90,9 24	12,5 16,7	101 26,7	13,9 18,5	111,1 29,4	15,3 20,4

Versioni Versions

73.5002.97.A - P

73.5102.97.A - PP



Destro/Right

Sinistro/Left

Sinistro/Left

COMPACT Series

BERTOLINI
pumps

CK Series CK 146



144 l/m
38.1 USGPM



max 60 BAR
870 P.S.I.

APPLICAZIONI - APPLICATIONS



ATOMIZZATORI
ATOMIZERS



CLEANING
CLEANING

SPECIAL TRADEMARK



EASylube™



INTELLiseal™



SMARTcase™

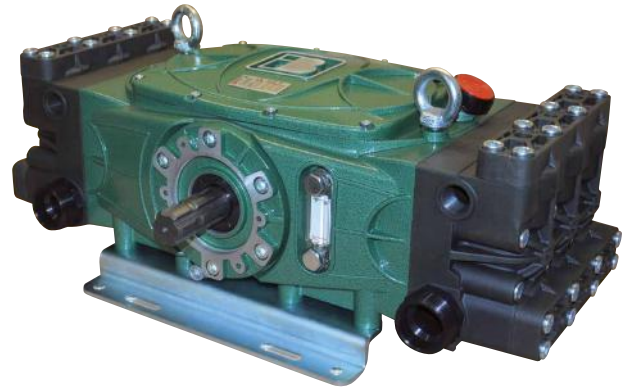
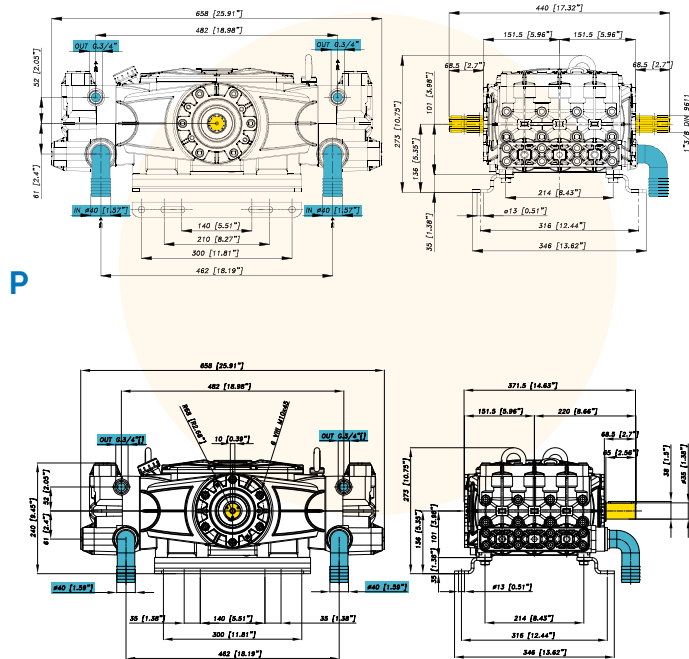

CARATTERISTICHE TECNICHE SPECIFICATIONS

550 g/min.
550 R.P.M.

Potenza - Power	16,6 KW	22.2 HP
Peso - Weight	39 Kg	85.8 lb
IN	2x40 mm	1"9/16 in
Pressione Min - Min Pressure	-0,15 BAR	- 2,17 P.S.I.
	-0,3 BAR (servizio discontinuo)	-0,435 P.S.I. (discontinuous service)
Pressione Max - Max Pressure	1 BAR	14.5 P.S.I.
OUT	G. 3/4	
Max. Temperatura - Max. Temperature	60 °C	140 °F
Tipo olio - Oil type	SAE 30	
Capacità olio - Oil capacity	2,8 lt	0.74 U.S.G.

TABELLA RENDIMENTI PERFORMANCE CHART

g/min R.P.M.	400		450		500		550		
	BAR P.S.I.	L/min USGPM	KW HP	L/min USGPM	KW HP	L/min USGPM	KW HP	L/min USGPM	KW HP
29	2	103,1	0,4	113,4	0,4	123,7	0,5	144,3	0,6
	29	27,2	0,5	30,0	0,6	32,7	0,6	38,1	0,8
290	20	102,1	4,0	112,4	4,4	122,6	4,8	143,0	5,6
	290	27,0	5,4	29,7	5,9	32,4	6,4	37,8	7,5
580	40	101,4	8,0	111,6	8,8	121,7	9,6	142,0	11,2
	580	26,8	10,6	29,5	11,7	32,2	12,8	37,5	14,9
870	60	100,7	11,9	110,8	13,1	120,9	14,2	141,0	16,6
	870	26,6	15,9	29,3	17,4	31,9	19,0	37,3	22,2

Versioni Versions

76.7310.97.3 - P

76.7311.97.3 - PP



Anteriore/Front

Posteriore/Rear

Anteriore/Front

CK Series CK 170



174 l/m
60 USGPM



max 60 BAR
870 P.S.I.

APPLICAZIONI - APPLICATIONS



ATOMIZZATORI
ATOMIZERS



CLEANING
CLEANING

SPECIAL TRADEMARK



EASYlube™



INTELLiseal™



SMARTcase™



SUPERCoolingSystem™

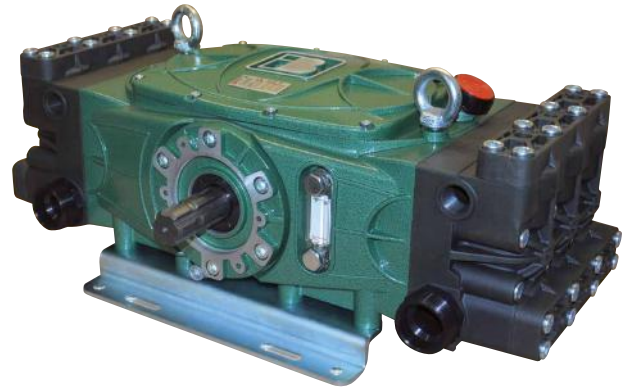
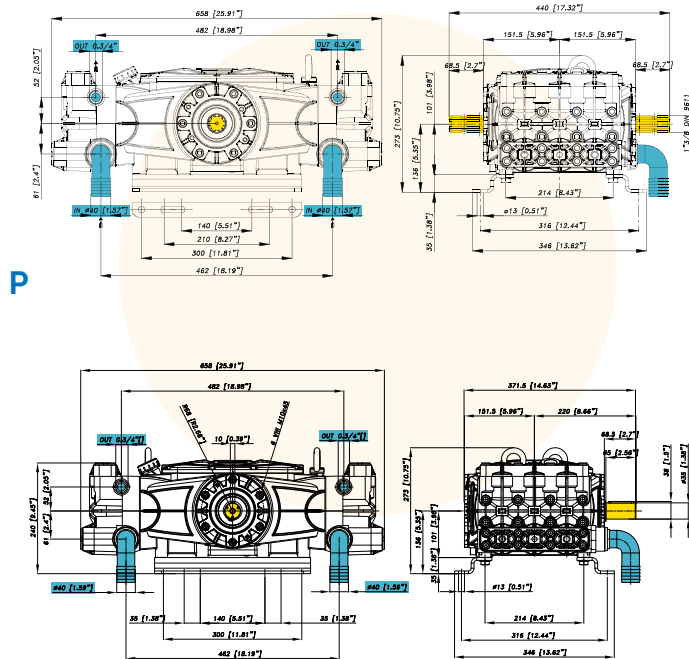

CARATTERISTICHE TECNICHE SPECIFICATIONS

550 g/min.
550 R.P.M.

Potenza - Power	20,1 KW	26.9 HP
Peso - Weight	39 Kg	85.8 lb
IN	2x40 mm	1"9/16 in
Pressione Min - Min Pressure	-0,15 BAR	- 2.17 P.S.I.
	-0,3 BAR (servizio discontinuo)	-0.435 P.S.I. (discontinuous service)
Pressione Max - Max Pressure	1 BAR	14.5 P.S.I.
OUT	G 3/4	
Max. Temperatura - Max. Temperature	60 °C	140 °F
Tipo olio - Oil type	SAE 30	
Capacità olio - Oil capacity	2,8 lt	0.74 U.S.G.

TABELLA RENDIMENTI PERFORMANCE CHART

g/min R.P.M.	400		450		500		550	
	L/min USGPM	KW HP	L/min USGPM	KW HP	L/min USGPM	KW HP	L/min USGPM	KW HP
2 29	126,5 33,4	0,5 0,7	142,4 37,6	0,6 0,7	158,2 41,8	0,6 0,8	174,0 46,0	0,7 0,9
20 290	125,8 33,2	4,9 6,6	141,5 37,4	5,6 7,4	157,3 41,6	6,2 8,3	173,0 45,7	6,8 9,1
40 580	125,1 33,0	9,8 13,1	140,7 37,2	11,1 14,8	156,4 41,3	12,3 16,4	172,0 45,4	13,5 18,0
60 870	124,4 32,9	14,7 19,6	139,9 37,0	16,5 22,0	155,5 41,1	18,3 24,5	171,0 45,2	20,1 26,9

Versioni Versions

76.7310.97.3 - P

76.7311.97.3 - PP



Anteriore/Front

Posteriore/Rear

Anteriore/Front

CK Series CK 180

177 l/m
46.8 USGPM

max 60 BAR
870 P.S.I.

APPLICAZIONI - APPLICATIONS



ATOMIZZATORI
ATOMIZERS



CLEANING
CLEANING

SPECIAL TRADEMARK

EL EASYlube™

Is INTELLiseal™

Sc SMARTcase™

SCs SUPERCoolingSystem™

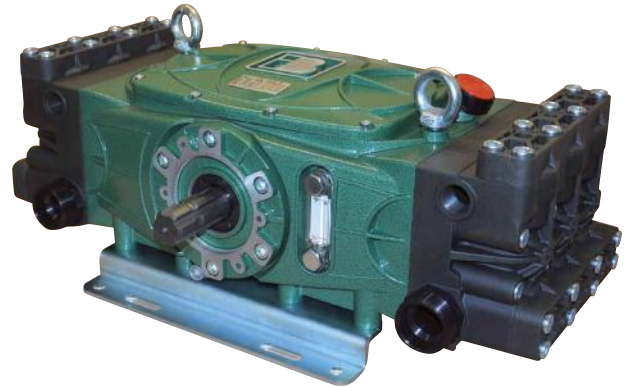
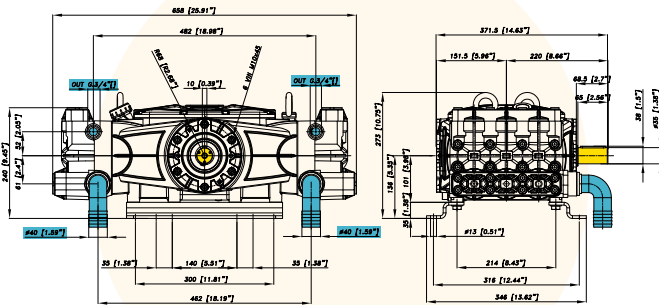

CARATTERISTICHE TECNICHE SPECIFICATIONS

550 g/min.
550 R.P.M.

Potenza - Power	23,9 KW	32.0 HP
Peso - Weight	39 Kg	85.8 lb
IN	2x40 mm	1"9/16 in
Pressione Min - Min Pressure	-0,15 BAR	- 2.17 P.S.I.
	-0,3 BAR (servizio discontinuo)	-0.435 P.S.I. (discontinuous service)
Pressione Max - Max Pressure	1 BAR	14.5 P.S.I.
OUT	G 3/4	
Max. Temperatura - Max. Temperature	60 °C	140 °F
Tipo olio - Oil type	SAE 30	
Capacità olio - Oil capacity	2,8 lt	0.74 U.S.G.

TABELLA RENDIMENTI PERFORMANCE CHART

g/min R.P.M.	600		700		800		900	
	BAR P.S.I.	L/min USGPM	KW HP	L/min USGPM	KW HP	L/min USGPM	KW HP	L/min USGPM
2 29	118,0 31,2	0,5 0,6	137,7 36,4	0,5 0,7	157,3 41,6	0,6 0,8	177,0 46,8	0,7 0,9
50 725	117,3 31,0	11,5 15,4	136,9 36,2	13,4 18,0	156,4 41,3	15,4 20,5	176,0 46,5	17,3 23,1
60 870	116,7 30,8	13,7 18,4	136,1 36,0	16,0 21,4	155,6 41,1	18,3 24,5	175,0 46,2	20,6 27,5
70 1015	116,0 30,6	15,9 21,3	135,3 35,8	18,6 24,9	154,7 40,9	21,3 28,4	174,0 46,0	23,9 32,0

Versioni Versions

76.7330.97.3 - PP



CK Series CK 220



205,5 l/m
54.3 USGPM



max 60 BAR
870 P.S.I.

APPLICAZIONI - APPLICATIONS



ATOMIZZATORI
ATOMIZERS



CLEANING
CLEANING

SPECIAL TRADEMARK



EASylube™



INTELLiseal™



SMARTcase™



SUPERCooling™

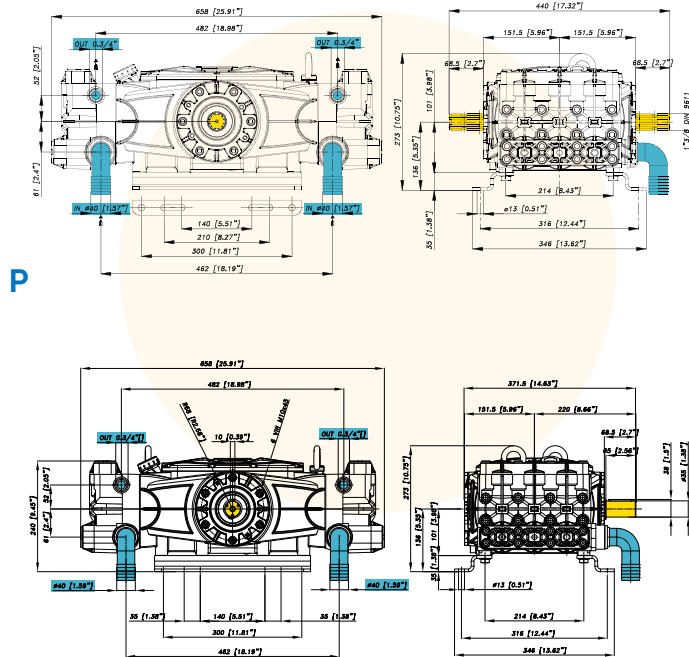

PP

CARATTERISTICHE TECNICHE SPECIFICATIONS	550 g/min. 550 R.P.M.	
Potenza - Power	23,7 KW	31.6 HP
Peso - Weight	39 Kg	85.8 lb
IN	2x40 mm	1"9/16 in
Pressione Min - Min Pressure	-0,15 BAR	- 2.17 P.S.I.
	-0,3 BAR (servizio discontinuo)	-0.435 P.S.I. (discontinuous service)
Pressione Max - Max Pressure	1 BAR	14.5 P.S.I.
OUT	G 3/4	
Max. Temperatura - Max. Temperature	60 °C	140 °F
Tipo olio - Oil type	SAE 30	
Capacità olio - Oil capacity	2,8 lt	0.74 U.S.G.

TABELLA RENDIMENTI PERFORMANCE CHART								
g/min R.P.M.	400		450		500		550	
BAR P.S.I.	L/min USGPM	KW HP	L/min USGPM	KW HP	L/min USGPM	KW HP	L/min USGPM	KW HP
2 29	149,5 39,5	0,6 0,8	168,1 44,4	0,7 0,9	186,8 49,4	0,7 1,0	205,5 54,3	0,8 1,1
20 290	148,4 39,2	5,8 7,8	166,9 44,1	6,6 8,8	185,5 49,0	7,3 9,7	204,0 53,9	8,0 10,7
40 580	147,6 39,0	11,6 15,5	166,1 43,9	13,0 17,4	184,5 48,8	14,5 19,4	203,0 53,6	15,9 21,3
60 870	146,2 38,6	17,2 23,0	164,5 43,4	19,4 25,9	182,7 48,3	21,5 28,8	201,0 53,1	23,7 31,6

Versioni Versions

76.7318.97.3 - P

76.7319.97.3 - PP



Anteriore/Front

Posteriore/Rear

Anteriore/Front

CK Series CK 230

224 l/m
59.2 USGPM

max 60 BAR
870 P.S.I.

APPLICAZIONI - APPLICATIONS



ATOMIZZATORI
ATOMIZERS



CLEANING
CLEANING

SPECIAL TRADEMARK

EL EASYlube™

Is INTELLiseal™

Sc SMARTcase™

SCs SUPERCoolINGsystem™

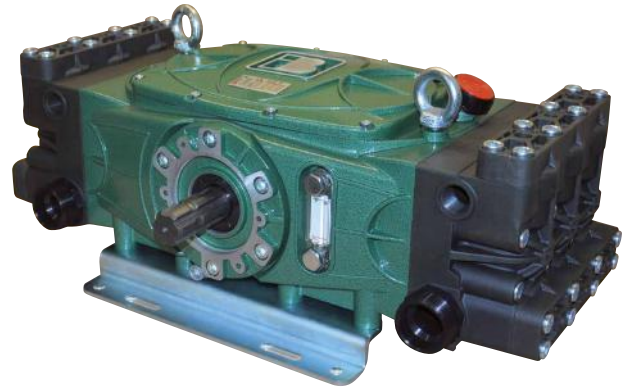
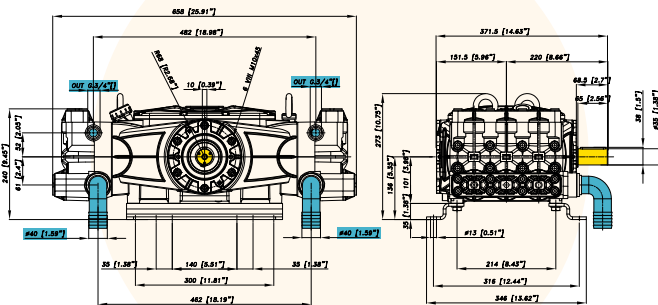

CARATTERISTICHE TECNICHE SPECIFICATIONS

550 g/min.
550 R.P.M.

Potenza - Power	26,0 KW	34.8 HP
Peso - Weight	39 Kg	85.8 lb
IN	2x40 mm	1"9/16 in
Pressione Min - Min Pressure	-0,15 BAR	- 2.17 P.S.I.
	-0,3 BAR (servizio discontinuo)	-0.435 P.S.I. (discontinuous service)
Pressione Max - Max Pressure	1 BAR	14.5 P.S.I.
OUT	G 3/4	
Max. Temperatura - Max. Temperature	60 °C	140 °F
Tipo olio - Oil type	SAE 30	
Capacità olio - Oil capacity	2,8 lt	0.74 U.S.G.

TABELLA RENDIMENTI PERFORMANCE CHART

g/min R.P.M.	600		700		800		900	
	BAR P.S.I.	L/min USGPM	KW HP	L/min USGPM	KW HP	L/min USGPM	KW HP	L/min USGPM
2 29	149,5 39,5	0,6 0,8	174,2 46,0	0,7 0,9	199,1 52,6	0,8 1,0	224,0 59,2	0,9 1,2
40 580	150,7 39,8	11,8 15,8	175,8 46,4	13,8 18,4	200,9 53,1	15,8 21,1	226,0 59,7	17,8 23,7
50 725	148,0 39,1	14,5 19,4	172,7 45,6	17,0 22,6	197,3 52,1	19,4 25,9	222,0 58,7	21,8 29,1
60 870	147,3 38,9	17,4 23,2	171,9 45,4	20,3 27,1	196,4 51,9	23,1 30,9	221,0 58,4	26,0 34,8

Versioni Versions

76.7331.97.3 - PP



CK Series CK 240



225,5 l/m
59.6 USGPM



max 60 BAR
870 P.S.I.

APPLICAZIONI - APPLICATIONS



ATOMIZZATORI
ATOMIZERS



CLEANING
CLEANING

SPECIAL TRADEMARK



EASylube™



INTELLiseal™



SMARTcase™



SUPERCooling™

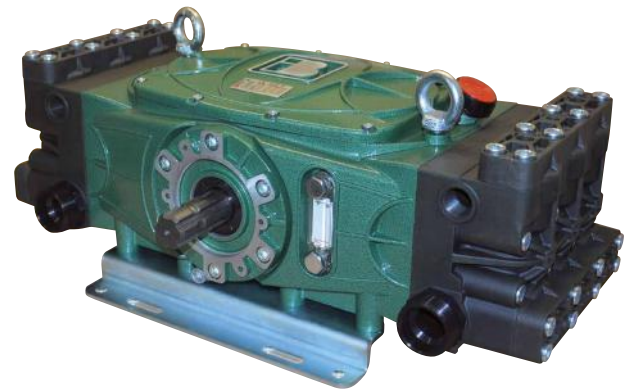
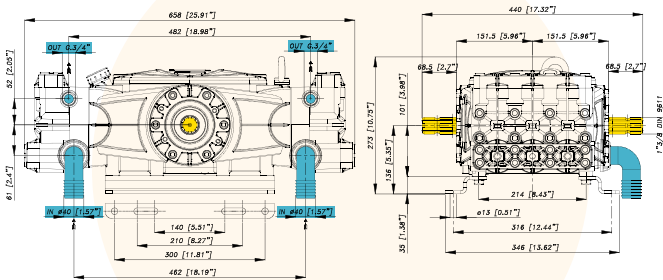

CARATTERISTICHE TECNICHE SPECIFICATIONS

Potenza - Power	26,2 KW	35.1 HP
Peso - Weight	39 Kg	85.8 lb
IN	2x40 mm	1"9/16 in
Pressione Min - Min Pressure	-0,15 BAR	- 2.17 P.S.I.
	-0,3 BAR (servizio discontinuo)	-0.435 P.S.I. (discontinuous service)
Pressione Max - Max Pressure	1 BAR	14.5 P.S.I.
OUT	G 3/4	
Max. Temperatura - Max. Temperature	60 °C	140 °F
Tipo olio - Oil type	SAE 30	
Capacità olio - Oil capacity	2,8 lt	0.74 U.S.G.

550 g/min.
550 R.P.M.

TABELLA RENDIMENTI PERFORMANCE CHART

g/min R.P.M.	400		450		500		550		
	BAR P.S.I.	L/min USGPM	KW HP	L/min USGPM	KW HP	L/min USGPM	KW HP	L/min USGPM	KW HP
2 29		164,0 43,3	0,6 0,9	184,5 48,7	0,7 1,0	205,0 54,2	0,8 1,1	225,5 59,6	0,9 1,2
20 280		162,9 43,0	6,4 8,5	183,3 48,4	7,2 9,6	203,6 53,8	8,0 10,7	224,0 59,2	8,8 11,8
40 580		162,2 42,8	12,7 17,0	182,5 48,2	14,3 19,1	202,7 53,6	15,9 21,3	223,0 58,9	17,5 29,1
60 870		161,5 42,7	19,0 25,4	181,6 48,0	21,4 28,6	201,8 53,3	23,8 31,8	222,0 58,7	26,2 35,1

Versioni Versions

76.7322.97.3 - P



Anteriore/Front

Posteriore/Rear

CK Series CK 270

272 l/m
71.9 USGPM

max 60 BAR
870 P.S.I.

APPLICAZIONI - APPLICATIONS

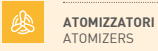

ATOMIZZATORI
ATOMIZERS



CLEANING
CLEANING

SPECIAL TRADEMARK

EL EASYtube™

Is INTELLiseal™

Sc SMARTcase™

SCs SUPERCoolINGsystem™

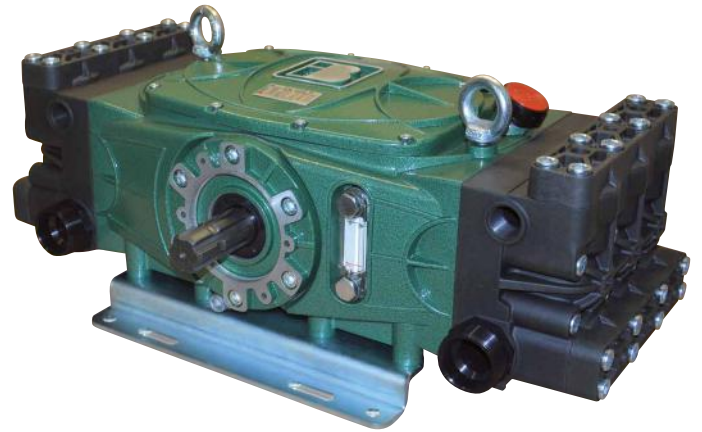
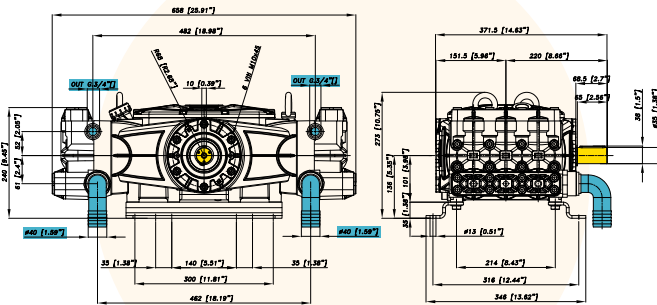

CARATTERISTICHE TECNICHE SPECIFICATIONS	550 g/min. 550 R.P.M.	
Potenza - Power	31,7 KW	42.3 HP
Peso - Weight	39 Kg	85.8 lb
IN	2x40 mm	1"9/16 in
Pressione Min - Min Pressure	-0,15 BAR	- 2.17 P.S.I.
	-0,3 BAR (servizio discontinuo)	-0.435 P.S.I. (discontinuous service)
Pressione Max - Max Pressure	1 BAR	14.5 P.S.I.
OUT	G 3/4	
Max. Temperatura - Max. Temperature	60 °C	140 °F
Tipo olio - Oil type	SAE 30	
Capacità olio - Oil capacity	2,8 lt	0.74 U.S.G.

TABELLA RENDIMENTI PERFORMANCE CHART								
g/min R.P.M.	600		700		800		900	
BAR P.S.I.	L/min USGPM	KW HP	L/min USGPM	KW HP	L/min USGPM	KW HP	L/min USGPM	KW HP
2 29	181,3 47,9	0,7 1,0	211,6 55,9	0,8 1,1	241,8 63,9	0,9 1,3	272,0 71,9	1,1 1,4
40 580	180,7 47,7	14,2 19,0	210,8 55,7	16,6 22,1	240,9 63,6	18,9 25,3	271,0 71,6	21,3 28,4
50 725	180,0 47,6	17,7 23,6	210,0 55,5	20,6 27,5	240,0 63,4	23,6 31,5	270,0 71,3	26,5 35,4
60 870	179,3 47,4	21,1 28,2	209,2 55,3	24,7 32,9	239,1 63,2	28,2 37,6	269,0 71,1	31,7 42,3

Versioni Versions

76.7332.97.3 - PP

