



## YMK 1" POMPA INTERNAL ECCENTRIC GEAR PUMP



### POMPA DEĞERLERİ / PUMP PROPERTIES

|       |                       |
|-------|-----------------------|
| Q     | : 2 m <sup>3</sup> /h |
| Hm    | :1 ~ 14 Bar           |
| T     | :0 ~ 120 °C           |
| n     | :1400 d/d             |
| Visc. | :100 ~ 7.500 SSU      |

### KULLANIM ALANLARI

- Fuel Oil Servis Tankları, Gaz Yağı, Mazot Tankerlerinde
- Küçük çapta kızgın yağ sirkülasyonlarında
- İlaç, kimya ve deterjan sanayinde,
- Gıda Sanayinde.

### USE AREAS

- Fuel Oil Service Tanks, Gasoil, Diesel Tankers
- Circulation of Hot Oil (limited)
- Medicine, Chemical and Detergent Industry
- Food Industry.

### MALZEME SEÇENEKLERİ

- Pompa Gövdesi, Kapaklar : Dökme (pik) demir, çelik döküm
- Dişliler : Dökme (pik) demir, çelik döküm, sfero döküm
- Yataklar : Snbz 12 bronz, karbon grafit, Silisyum Karbür, Sert Metal Kaplama
- Sızdırmazlık: Keçeli Sistem

### MATERIAL OPTIONS

- Pump Body, covers : Cast iron, steel cast
- Gears : Cast iron, steel cast, Spheroidal cast iron.
- Bearings: Snbz 12 bronze, carbon graphite, silicon carbide, hard metal coated steel.
- Sealing: Lip seal



## YMK 1" POMPA INTERNAL ECCENTRIC GEAR PUMP



### İÇTEN EKSANTİK DİŞLİ POMPA ÇALIŞMA PRENSİBİ / WORKING PRINCIPLE OF INTERNAL ECCENTRIC GEAR PUMP

Yıldız Pompa' nın "dişli içinde dişli" prensibinde sadece iki tane hareketli parça vardır. Bütün pozitif deplasmanlı YILDIZ dişli pompalarının güvenilir ve verimli çalışmasının sırrı budur. Sıvının pozitif deplasmanı (yer değiştirmesi) rotor ve avare dişlisinin dişleri arasındaki boşluğun komple dolmasıyla sağlanmaktadır. Bütün dişli pompalarda olduğu gibi, YILDIZ POMPA' da da performansın en üst noktaya çıkmasını sınırlayıcı yegane faktör, pompalanan sıvının diğerlerine göre daha temiz olmasını istemesidir.

Pompa milinin her devrinde emiş ağzı yoluyla belli bir miktar sıvı pompaya girer. Bu sıvı rotor ile avare dişlisi arasındaki boşluğu doldurur. Pompa kapağında bulunan hilal, çıkış ağzına doğru pürüzsüz şekilde hareket eden sıvının akışını ayırır. Kendi dişleri ile hilalin iç yüzeyi arasında sıvıyı taşıyan avare dişlisi pompa kapağının desteklediği bir mil üzerinde döner. Dişleri arasında sıvıyı taşıyan rotor dişlisi pompa gövdesi ile hilalin dış yüzeyi arasında hareket eder ve pompa miline bağlıdır.

*YILDIZ's simple "gear-within a gear" principle has only two moving parts. It is the secret of dependable, efficient operation of all positive displacement YILDIZ POMPA's PUMPS. The positive displacement of liquid is accomplished by the complete filling of the spaces between the teeth of the rotor and idler gears. The only limiting factor to peak performance in YILDIZ POMPA, as with all rotary pumps, is that the liquid pumped must be comparatively clean.*

*With every revolution of the pump's shaft, a definite amount of liquid enters the pump through the suction port. This liquid fills the spaces between the teeth of the rotor and the idler. The crescent on the pump head splits the flow of liquid as it moves smoothly towards the discharge port. The idler gear, which carries the liquid between its teeth and the inside surface of the crescent is connected to pump cover. On the otherhand, rotor gear which is rotated directly with pump shaft delivers the liquid between gear teeth and crescent's souter surface.*

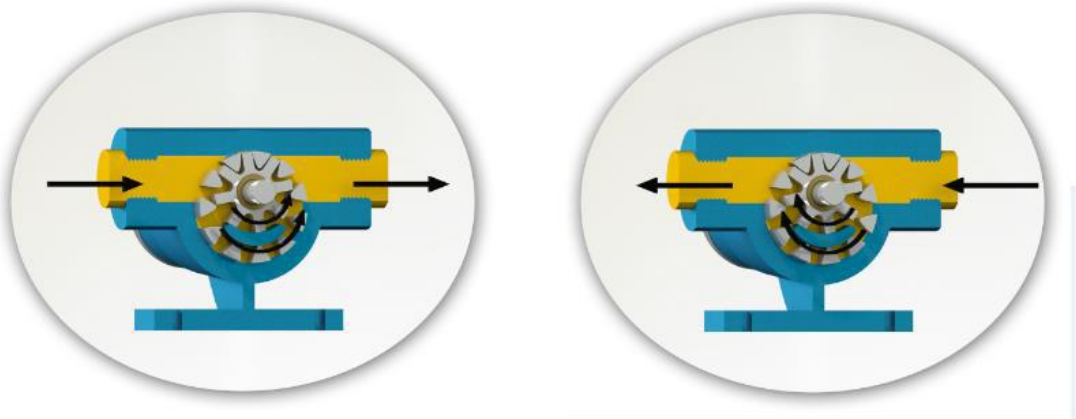

## YMK 1" POMPA INTERNAL ECCENTRIC GEAR PUMP

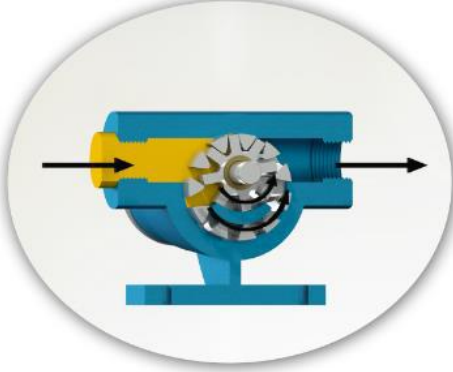

Yandaki renkli kısım sıvının pompa gövdesindeki emiş ağızı alanına, rotor dişlisi ve avare dişlisi dişleri arasındaki dişli boşlukları alanına girişini gösterir. İki siyah ok pompanın dönüş ve sıvının ilerleyişini gösterir.

*The yellow colored portion at side indicates the liquid as it enters the suction port area of the casing and the area between the rotor teeth and corresponding concave area between the idler teeth. The two black arrows indicate the pump rotation and progress of the liquid.*

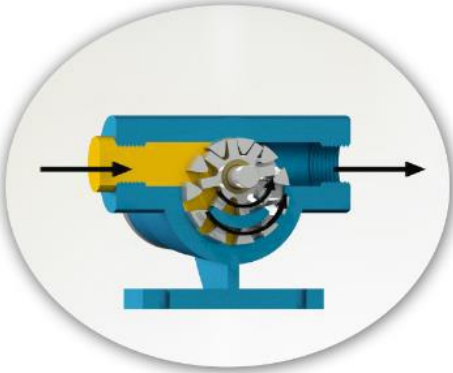

"Dişli içinde dişli" prensibinde çalışan dişliler ile pompa içinde sıvının ilerleyişine dikkat edin. Aynı zamanda, pompa kapağı üzerindeki hilal şeklinin sıvıyı nasıl böldüğüne ve emiş ile boşaltma ağızları arasında bir keçe (conta) gibi vazife gördüğüne dikkat ediniz.

*Notice the progress of the liquid through the pump and between the teeth of rotor idler gear. Also, note how the crescent shape on the head divides the liquid and acts as a seal between the suction and discharge ports.*

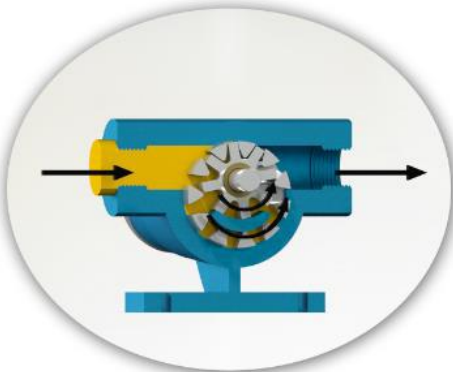

Bu resim pompanın iç kısmının dolup sıvının boşaltma ağızı alanına itilmesinden hemen önceki durumunu göstermektedir. Avare ve rotor dişlilerinin dizaynının sıvı için nasıl bir kapalı cep oluşturduğuna ve bunun tam bir hacim kontrolü sağlanmasını nasıl garantilediğine dikkat ediniz.

*This illustration shows the pump in a nearly flooded condition just previous to the liquid being forced into the discharge port area. Notice how the gear design of the idler and rotor form locked pockets for the liquid to guarantee absolute volume control.*

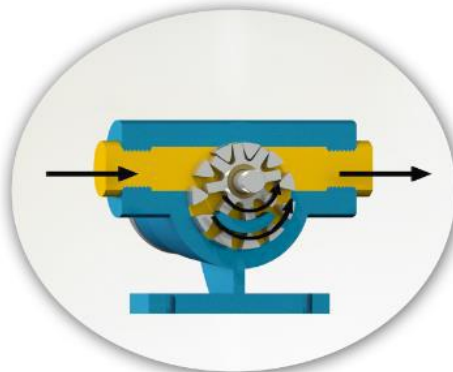

Bu görüntü pompanın tamamen dolup taşıdığı durumu ve sıvının boşaltma işlemini, boşaltma ağızından ilerleyişini göstermektedir. Emiş ve boşaltma ağızlarına eşit mesafede sızdırmaz bir keçe oluşturan, sıvıyı boşaltma ağızından dışarı doğru iten, rotor ve avare dişlisinin dişleri birbiri içine geçer.

*The view shows the pump in a completely flooded condition and in the process of discharging the liquid through discharge port. The rotor and idler teeth mesh, forming a seal equidistant between the both ports, forcing liquid out the discharge port.*





## YMK 1" POMPA INTERNAL ECCENTRIC GEAR PUMP



| YMK-1" POMPASINA AİT KAPASİTE VE GÜÇ TABLOSU /<br>CAPACITY AND POWER TABLE |                            |                          |         |         |        |                        |
|--|----------------------------|--------------------------|---------|---------|--------|------------------------|
| KAPASİTE (m <sup>3</sup> /h)<br>CAPACITY (Q)                               | DEVİR (d/d)<br>SPEED (rpm) | ÇIKIŞ BASINCI / PRESSURE |         |         |        | VİSKOZİTE<br>VISCOSITY |
|  |                            | 2,5 Bar                  | 5 Bar   | 7,5 Bar | 10 Bar |                        |
| 1,2  | 900                        | 0,5 HP                   | 0,75 HP | 0,75 HP | 1 HP   | 750 SSU                |
| 2  | 1400                       | 0,75 HP                  | 1 HP    | 1 HP    | 1,5 HP | 100 SSU                |

  

| MOTOR GÜÇLERİ<br>MOTOR POWERS |                | MOTOR GÜÇLERİ<br>MOTOR POWERS |                |
|-------------------------------|----------------|-------------------------------|----------------|
| 0,5 HP                        | 900 d/d (rpm)  | 1 HP                          | 900 d/d (rpm)  |
| 0,75 HP                       | 900 d/d (rpm)  | 1,5 HP                        | 900 d/d (rpm)  |
| 0,75 HP                       | 1400 d/d (rpm) | 1,5 HP                        | 1400 d/d (rpm) |
| 1 HP                          | 1400 d/d (rpm) |                               |                |

| MOTOR GÖVDESİ<br>MOTOR BODY | MOTOR GÖVDESİ<br>MOTOR BODY |
|-----------------------------|-----------------------------|
| 80                          | 90                          |

### KAPASİTE EĞRİLERİ / CAPACITY GRAPHS



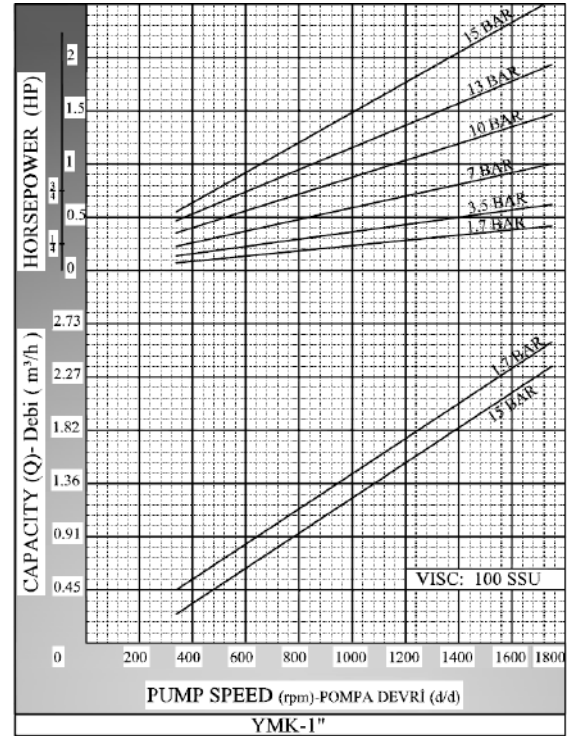
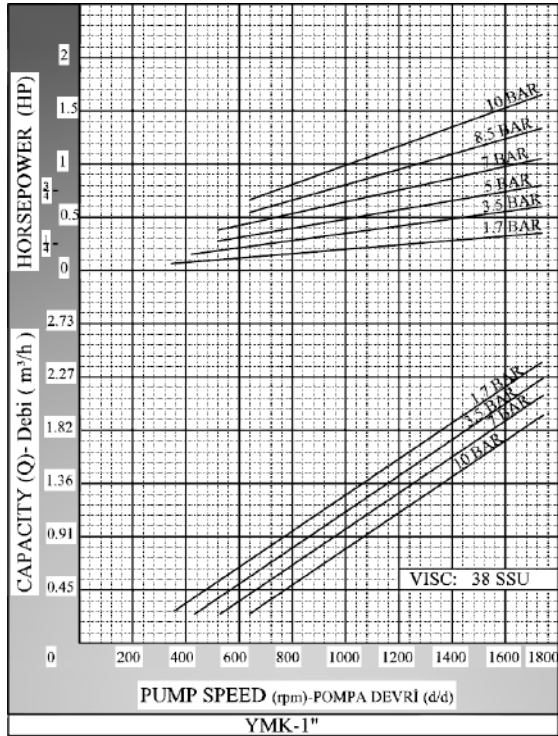

**YILDIZ  
POMPA**

ilpomp

**YMK 1" POMPA  
INTERNAL ECCENTRIC  
GEAR PUMP**

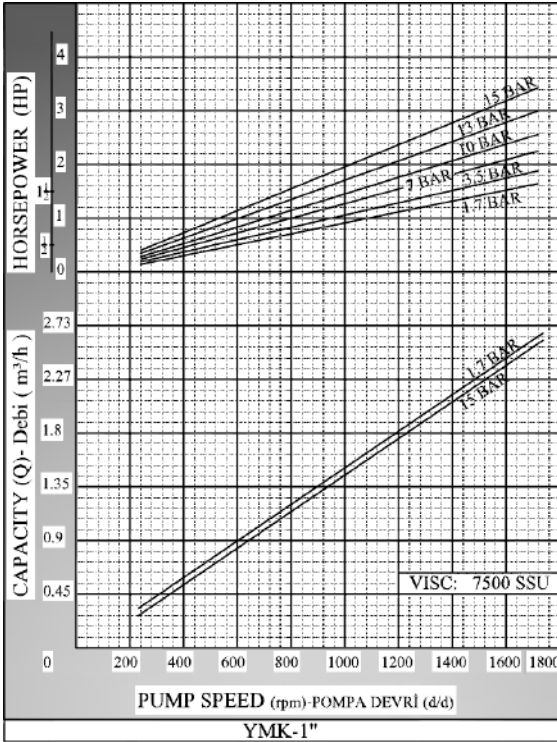
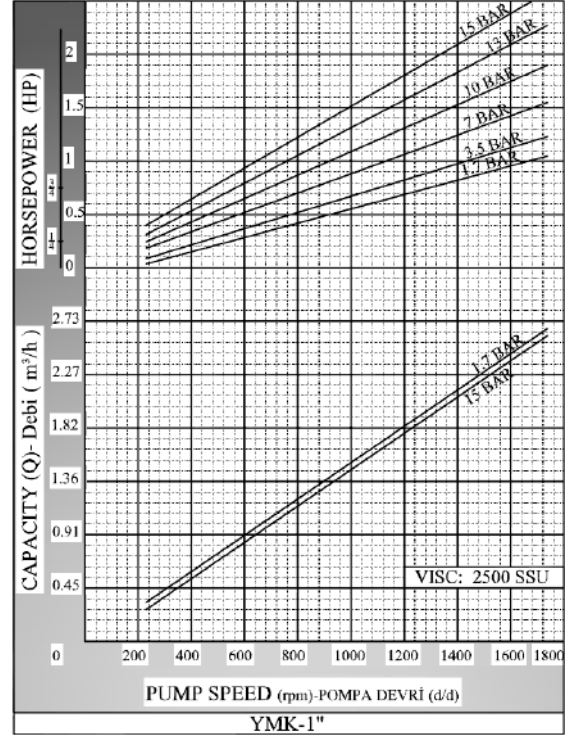
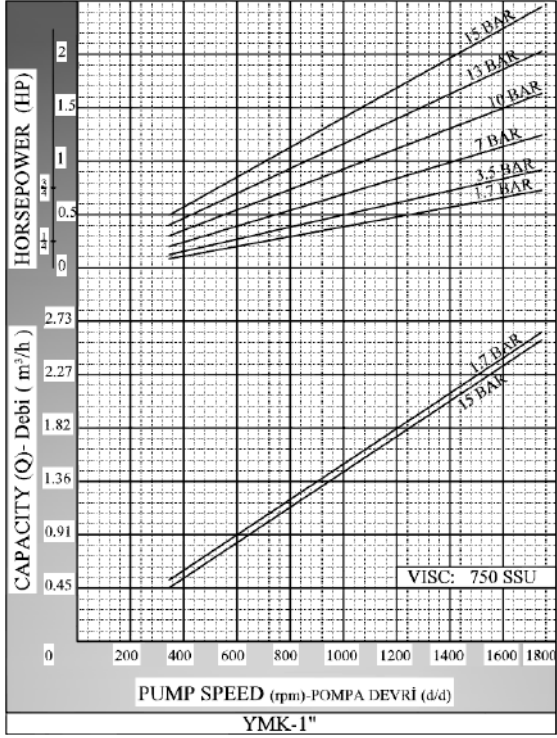



**YILDIZ  
POMPA**

ilpomp

**YMK 1" POMPA  
INTERNAL ECCENTRIC  
GEAR PUMP**



**POMPA BOYUT ÖLÇÜLERİ / PUMP DIMENSIONS**

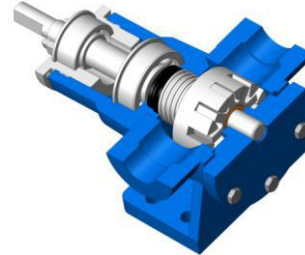
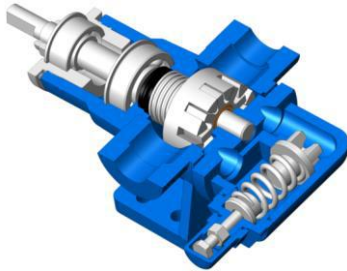
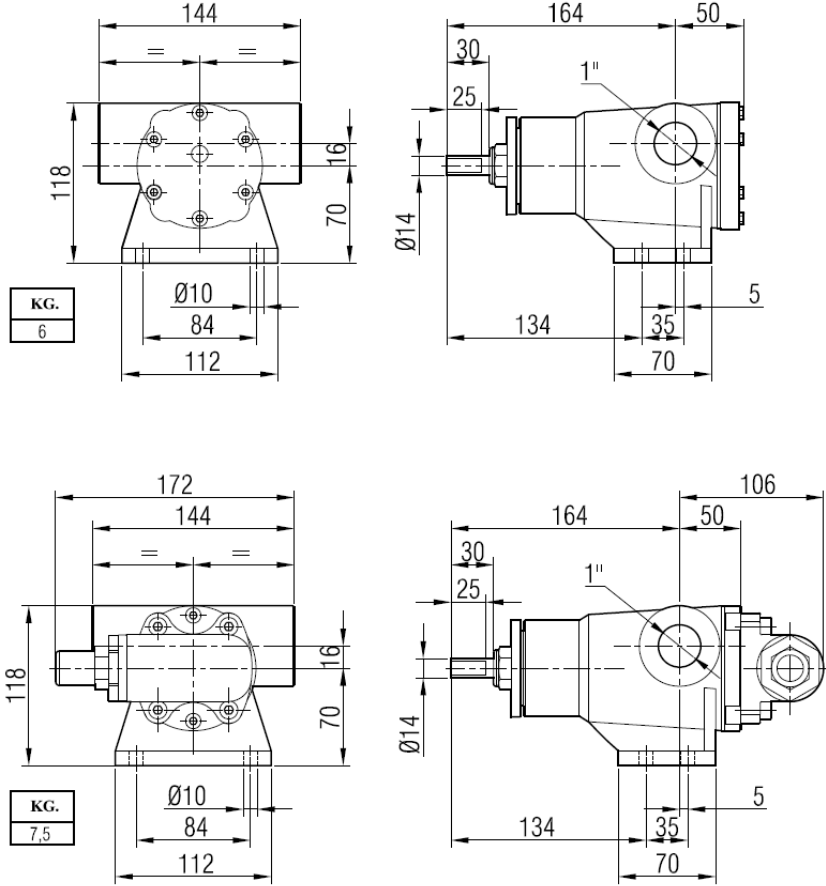





## YMK 1" POMPA INTERNAL ECCENTRIC GEAR PUMP



### AKUPLAJ ÖLÇÜLERİ / COUPLING DIMENSIONS MOTOR VE REDÜKTÖR AKUPELİ / MOTOR AND GEARBOX DRIVE

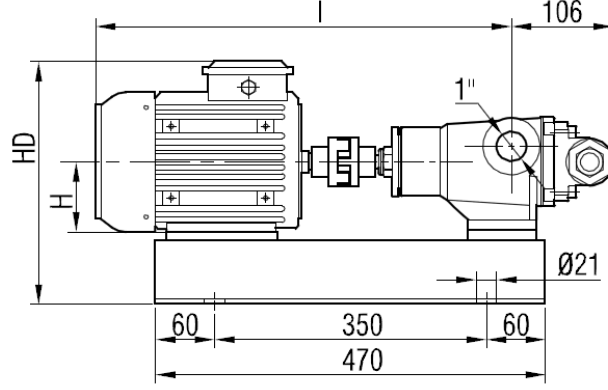
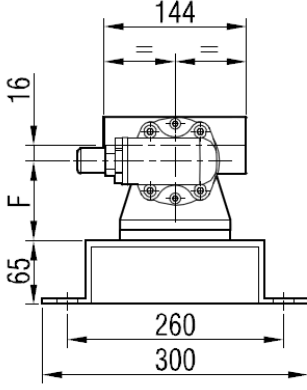

| MOTOR GÜÇ VE DEVİRLERİ /<br>MOTOR POWER AND SPEED |  |           | I   | HD  | H  | F  | kg. |    |
|---|--|-----------|-----|-----|----|----|-----|----|
| 0,5-0,75hp /0,37-0,55kw<br>900 d/d (rpm)          | 0,75-1hp/0,55-0,75kw<br>1400 d/d (rpm) | MOTOR 80  | 471 | 263 | 80 | 80 | 26  | 26 |
| 1 hp / 0,75 kw<br>900 d/d (rpm)                   | 1,5 hp / 1,1 kw<br>1400 d/d (rpm)      | MOTOR 90S | 501 | 281 | 90 | 90 | 30  |    |
| 1,5 hp / 1,1 kw<br>900 d/d (rpm)                  | 2 hp / 1,5 kw<br>1400 d/d (rpm)        | MOTOR 90L | 553 |     |    |    | 32  |    |

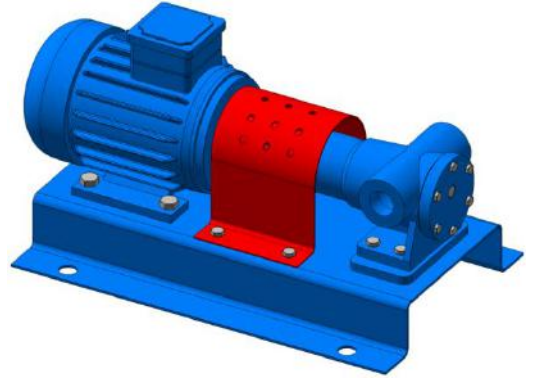
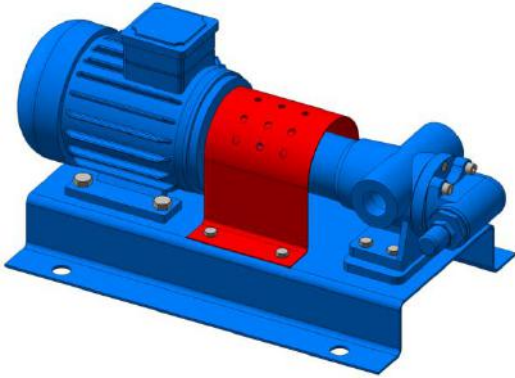



## YMK 1" POMPA INTERNAL ECCENTRIC GEAR PUMP

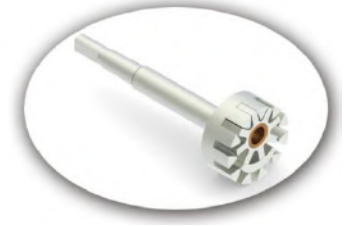

### YEDEK PARÇA LİSTESİ / SPARE PARTS LIST

MEKANİK SALMASTRALI VE BYPASSLI / SEALED WITH MECHANICAL SEAL, AND PRESSURE RELIEF VALVE ON COVER

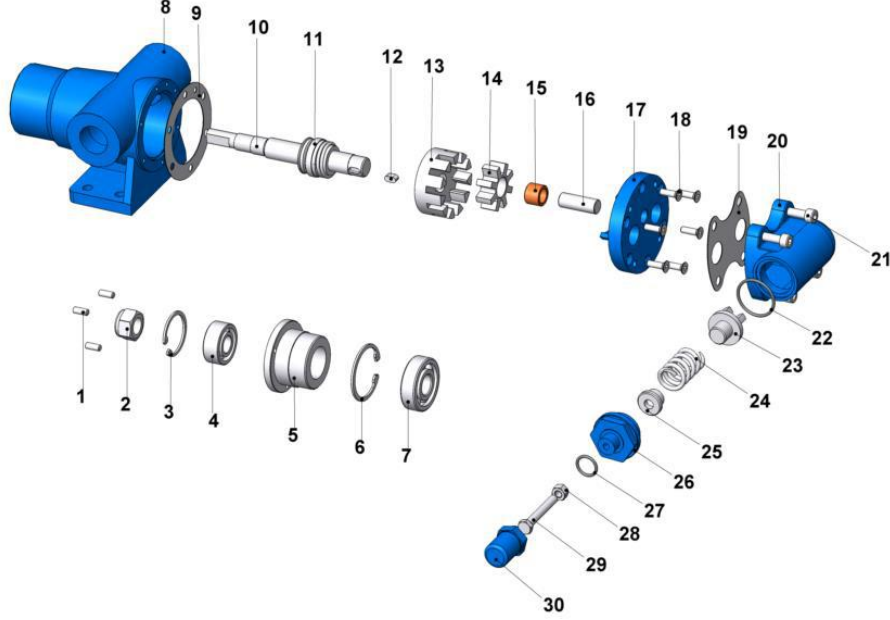

| No | PARÇA İSMİ            | PART NAME                     | ADET/<br>QTY | No | PARÇA İSMİ               | PART NAME                      | ADET/<br>QTY |
|----|-----------------------|-------------------------------|--------------|----|--------------------------|--------------------------------|--------------|
| 1  | SETUSKUR M6x16        | GRUB SCREW M6x16              | 3            | 16 | KAPAK MİLİ               | COVER PIN                      | 1            |
| 2  | TAMBUR SOMUNU         | PULLEY NUT                    | 1            | 17 | KAPAK (BYPASSLI)         | COVER (w/ BYPASS INLETS)       | 1            |
| 3  | TAMBUR SEGMANI (Ø40)  | PULLEY INTERNAL CIRCLIP (Ø40) | 1            | 18 | HAVŞA BAŞLI CİVATA M6x20 | COUNTERSUNK BOLT M6x20         | 6            |
| 4  | RULMAN (62203-2RS)    | BALL BEARING (62203-2RS)      | 1            | 19 | BYPASS CONTASI           | RELIEF VALVE GASKET            | 1            |
| 5  | TAMBUR                | PULLEY                        | 1            | 20 | BYPASS                   | PRESSURE RELIEF VALVE - BYPASS | 1            |
| 6  | GÖVDE SEGMANI (Ø52)   | CASING INTERNAL CIRCLIP (Ø52) | 1            | 21 | IMBUS CİVATA M8x25       | INBUS BOLT M8x25               | 4            |
| 7  | RULMAN (6304-2RS)     | BEARING (6304-2RS)            | 1            | 22 | BYPASS O-RING            | RELIEF VALVE O-RING            | 1            |
| 8  | GÖVDE                 | CASING                        | 1            | 23 | KLEPE                    | VALVE                          | 1            |
| 9  | KAPAK CONTASI         | COVER GASKET                  | 1            | 24 | YAY                      | SPRING                         | 1            |
| 10 | MİL                   | SHAFT                         | 1            | 25 | PUL                      | BYPASS WASHER                  | 1            |
| 11 | MEKANİK SALMASTRA Ø20 | MECHANICAL SEAL Ø20           | 1            | 26 | BYPASS KAPAĞI            | BYPASS COVER                   | 1            |
| 12 | KAMA 6x6x12 A         | KEY 6x6x12 A                  | 1            | 27 | TİJ KAPAK O-RİNG         | BYPASS O-RING                  | 1            |
| 13 | ÇEVRE DİŞLİ           | ROTOR GEAR                    | 1            | 28 | M8 SOMUN                 | M8 NUT                         | 1            |
| 14 | AVARA DİŞLİ           | IDLER GEAR                    | 1            | 29 | 6 KÖŞE CİVATA M8x55      | ADJUSTING SCREW M8x55          | 1            |
| 15 | AVARA DİŞLİ BURCU     | IDLER GEAR BUSHING            | 1            | 30 | TİJ KAPAĞI               | CAP                            | 1            |





## YMK 1" POMPA INTERNAL ECCENTRIC GEAR PUMP



### YEDEK PARÇA LİSTESİ / SPARE PARTS LIST MEKANİK SALMASTRALI VE KÖR KAPAKLI / SEALED WITH MECHANICAL SEAL, AND WITH BLIND COVER

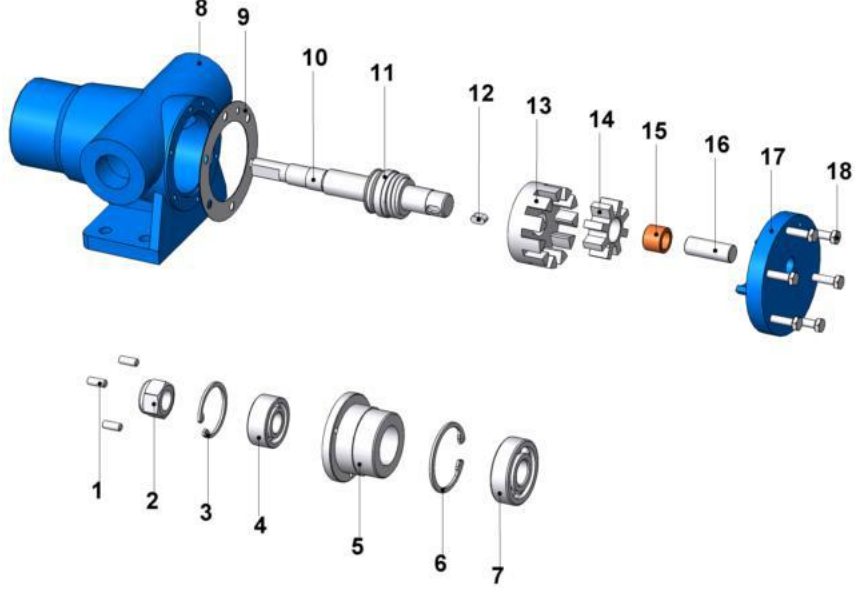

| No | PARÇA İSMİ            | PART NAME                     | ADET/<br>QTY |
|----|-----------------------|-------------------------------|--------------|
| 1  | SETUSKUR M6x16        | GRUB SCREW M6x16              | 3            |
| 2  | TAMBUR SOMUNU         | PULLEY NUT                    | 1            |
| 3  | TAMBUR SEGMANI (Ø40)  | PULLEY INTERNAL CIRCLIP (Ø40) | 1            |
| 4  | RULMAN (62203-2RS)    | BALL BEARING (62203-2RS)      | 1            |
| 5  | TAMBUR                | PULLEY                        | 1            |
| 6  | GÖVDE SEGMANI (Ø52)   | CASING INTERNAL CIRCLIP (Ø52) | 1            |
| 7  | RULMAN (6304-2RS)     | BALL BEARING (6304-2RS)       | 1            |
| 8  | GÖVDE                 | CASING                        | 1            |
| 9  | KAPAK CONTASI         | COVER GASKET                  | 1            |
| 10 | MİL                   | SHAFT                         | 1            |
| 11 | MEKANİK SALMASTRA Ø20 | MECHANICAL SEAL Ø20           | 1            |
| 12 | KAMA 6x6x12 A         | KEY 6x6x12 A                  | 1            |
| 13 | ÇEVRE DİŞLİ           | ROTOR GEAR                    | 1            |
| 14 | AVARA DİŞLİ           | IDLER GEAR                    | 1            |
| 15 | AVARA DİŞLİ BURCU     | IDLER GEAR BUSHING            | 1            |
| 16 | KAPAK MİLİ            | COVER PIN                     | 1            |
| 17 | KAPAK (KÖR)           | BLIND COVER                   | 1            |
| 18 | 6 KÖŞE CIVATA M6x20   | HEX BOLT M6x20                | 6            |