

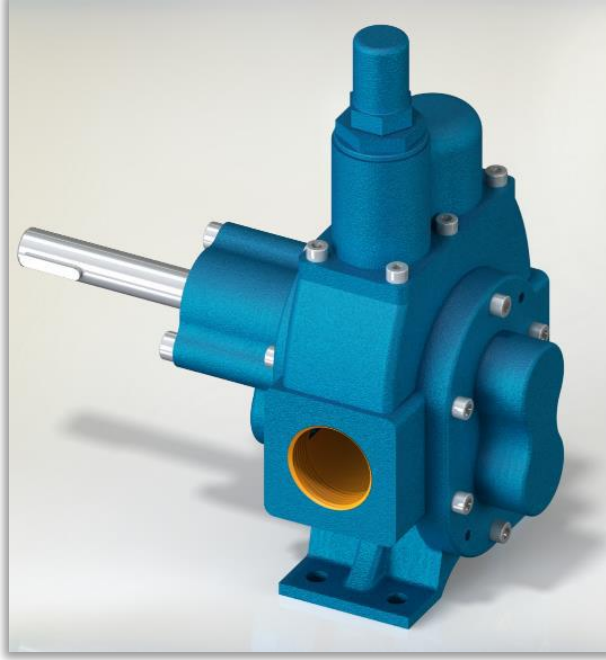

## YMDY 2 POMPA MODULAR GEAR PUMP



OMPA DEĞERLERİ / PUMP PROPERTIES	
Q	:7 m <sup>3</sup> /h
Hm	:1 ~ 12 Bar
T	:0 ~ 70 °C
n	:1 ~ 1500 d/d
Visc.	:100 ~ 2500 SSU

### KULLANIM ALANLARI

- Fuel Oil Servis Tankları, Gaz Yağı, Mazot Tankerlerinde
- Küçük çapta kızgın yağ sirkülasyonlarında
- Endüstrinin yarı viskoz mayilerinin pompaj işlemlerinde.
- Boya Sanayinde
- Gemi Sektörü

### USE AREAS

- Fuel Oil Service Tanks, Gas Oil, Diesel-fuel Tanks.
- On a small scale hot oil circulations
- Half viscose liquids of industry are on pumping process
- Dye Industry
- Ship Sector

### MALZEME SEÇENEKLERİ

- Pompa Gövdesi ve Kapaklar : Dökme (pik) demir, çelik döküm, paslanmaz AISI 304 / 316 döküm, sfero döküm
- Dişliler: Çelik, paslanmaz çelik AISI 304 / AISI 316
- Yataklar : Snbz 12 bronz, rulman, karbon grafit, ina burc
- Sızdırmazlık: Yumuşak salmastra, mekanik salmastra, keçe

### MATERIAL OPTIONS

- Pump Body and covers: Cast iron, steel cast, stainless AISI 304 / 316 cast.
- Gears: Steel, stainless steel AISI 304 / AISI 316.
- Bearings: Snbz 12 bronze, bearing, carbon graphite, Ina bushing bearing.
- Sealing: Soft seal, mechanical seal, lip seal



## YMDY 2 POMPA MODULAR GEAR PUMP



### MODÜL DİŞLİ POMPA ÇALIŞMA PRENSİBİ / WORKING PRINCIPLE OF MODULAR GEAR PUMP

Bu pompalar da dişli pompa prensibiyle çalışır. Pompa mili, motordan almış olduğu dairesel hareketi, mil üzerindeki dişli (çeviren) ile, diğer dişliye (çevrilen) ters yönde iletir. Dişliler birbirinden ayrılırken, dişlilerin arasına sıvı dolar. Bu sıvı, dönme hareketi ile basma bölgesine taşınarak, dişliler iç içe girerken basma kanalına atılır.

Korozif (Aşındırıcı) ve az hacimli akışkanın hızlı bir şekilde transfer edilmesini sağlar. Kompakt oldukları için güvenilirlik sunmaktadırlar.

*These pumps operates according to the same principle of gear pumps'. Pump shaft transmits circular movement with its own gear (driving) to the other gear (driven) in opposite rotation direction. During suction, liquid fills gaps between gears' teeth. While in discharge, due to mashing between teeth of both gears rotation forces the liquid outside of outlet port.*

*Corrosive and low volumes could be transferred in short time. Reliability is provided thanks to pumps compact design.*

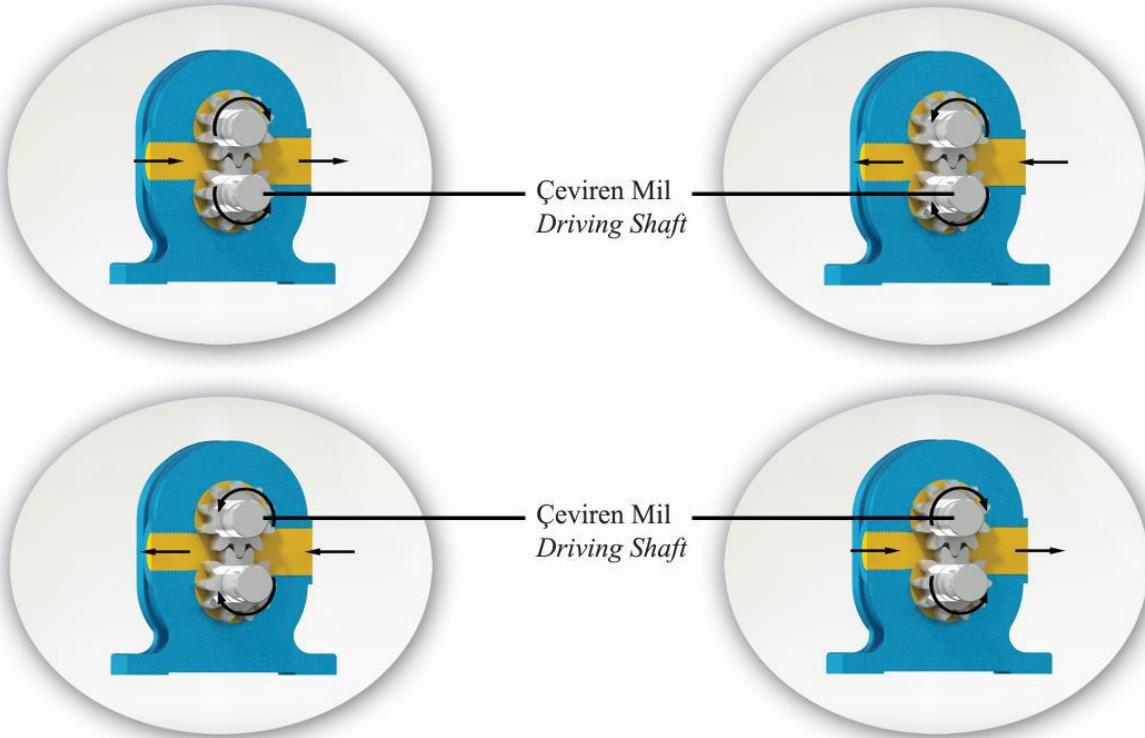

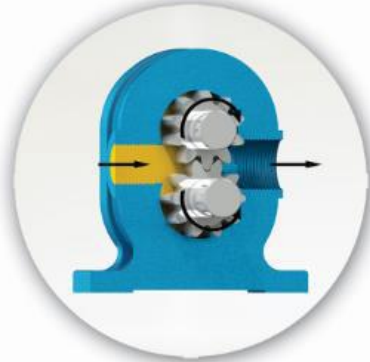

Yandaki renkli kısım sıvının pompa gövdesindeki emiş ağız alanına, çeviren ve çevrilen dişlilerin dişli boşlukları alanına girişini gösterir. Siyah oklar pompanın dönüş ve sıvının ilerleyişini gösterir.

*In this picture, liquid is illustrated while filling suction port and gaps between gears' teeth. Black arrows shows rotation direction and forwarding of the liquid.*

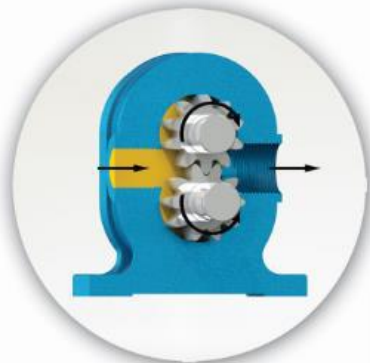

Görüldüğü gibi akışkan taşınması dişliler ile dişlileri içinde barındıran gövde arasında olmaktadır. Akışkan dişliler arasından geçmemektedir.

*As shown, transferring of the liquid is done by casing and gears within it. Liquid is not passing in between gears.*

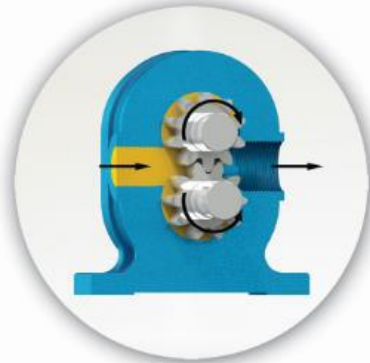

Bu resim pompanın iç kısmının dolup sıvının boşaltma ağız alanına itilmesinden hemen önceki durumunu göstermektedir. Çeviren ve çevrilen modül dişlilerin diş boşluklarının sıvı için nasıl bir kapalı cep oluşturduğuna ve bunun tam bir hacim kontrolü sağlanmasını nasıl garantilediğine dikkat ediniz.

*This picture shows the situation of the liquid filling pump inner side and just right before passing to discharge area. Pay attention how driving and driven gears guarantees volume control and a closed area for the liquid.*

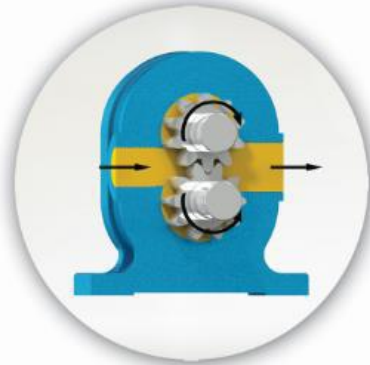

Bu görüntü pompanın tamamen dolup taşıdığı durumu ve sıvının boşaltma işlemini, boşaltma ağızından ilerleyişini göstermektedir. Sonunda birbirine geçen dişlilerin gücü ile akışkan basınç altında çıkış ağızına iletilir.

*Picture here shows liquid discharge process and forwarding. Pressure gained due to meshing for teeth forces the liquid to the outlet port.*



## YMDY 2 POMPA MODULAR GEAR PUMP



YMDY2" POMPASINA AİT KAPASİTE VE GÜÇ TABLOSU / CAPACITY AND POWER TABLE							
KAPASİTE (m <sup>3</sup> /h) CAPACITY (Q)	DEVİR (d/d) SPEED (rpm)	ÇIKIŞ BASINCI / PRESSURE			VİSKOZİTE VISCOSITY		
		0 Bar	3,5 Bar	7 Bar			
3,3	750	3 HP	4 HP	5,5 HP	2500 SSU		
4,2	900	2 HP	3 HP	4 HP	750 SSU		
5,7	1400	2 HP	3 HP	4 HP	100 SSU		
MOTOR GÜÇLERİ MOTOR POWERS		MOTOR GÜÇLERİ MOTOR POWERS		MOTOR GÜÇLERİ MOTOR POWERS		MOTOR GÜÇLERİ MOTOR POWERS	
2 HP	1400 d/d (rpm)	2 HP	1000 d/d (rpm)	3 HP	900 d/d (rpm)	3 HP	750 d/d (rpm)
MOTOR GÖVDESİ MOTOR BODY		3 HP	1400 d/d (rpm)	MOTOR GÖVDESİ MOTOR BODY		4 HP	750 d/d (rpm)
90		4 HP	1400 d/d (rpm)	112		4 HP	900 d/d (rpm)
		MOTOR GÖVDESİ MOTOR BODY				MOTOR GÖVDESİ MOTOR BODY	
		100				132	

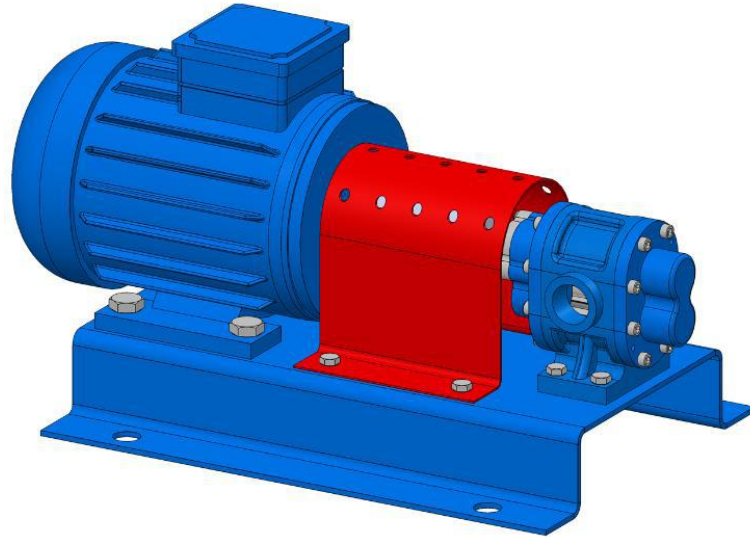



**YILDIZ  
POMPA**

ilpomp

## YMDY 2 POMPA MODULAR GEAR PUMP



### KAPASİTE EĞRİLERİ / CAPACITY GRAPHS

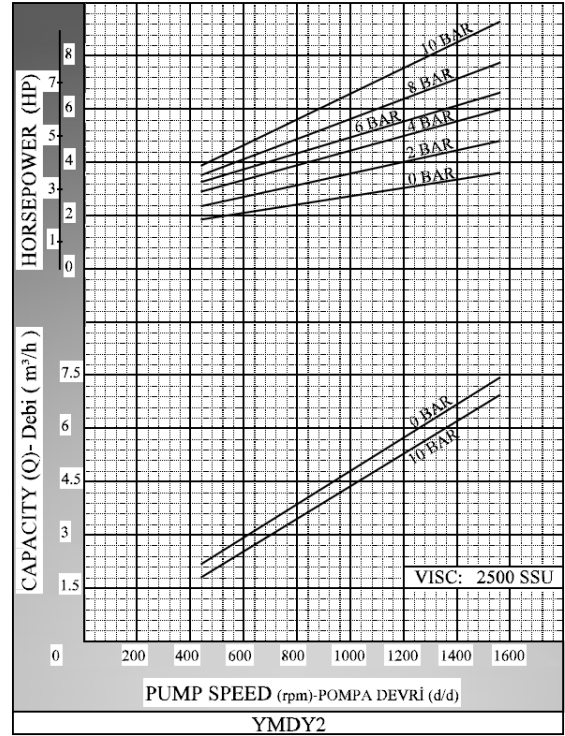
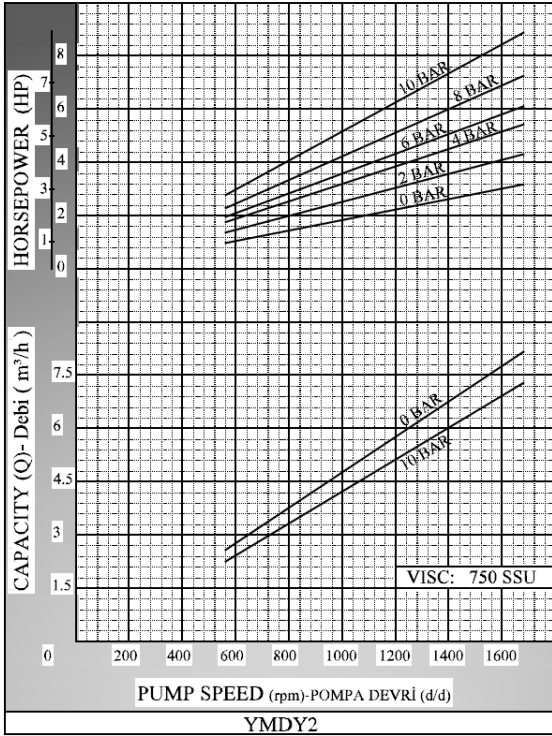
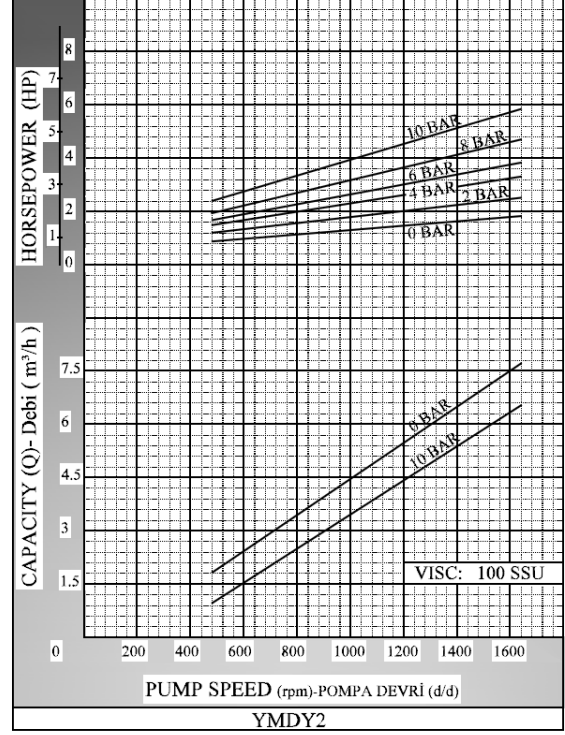
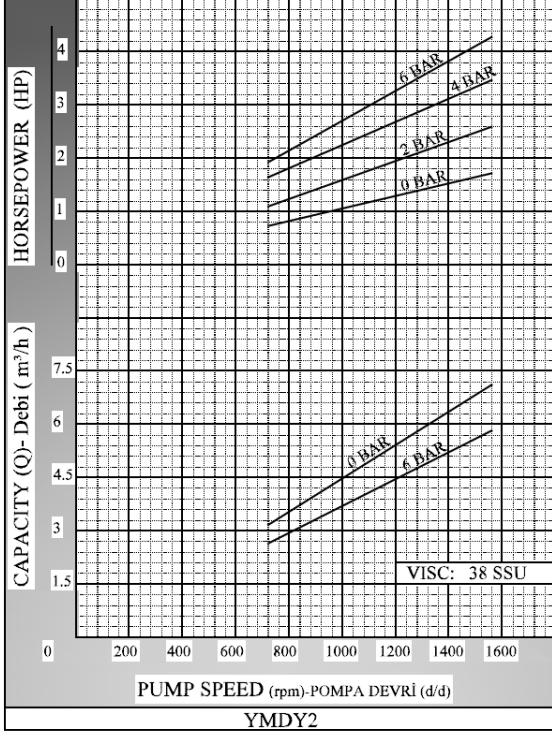



**YILDIZ  
POMPA**

ilpomp

**YMDY 2 POMPA  
MODULAR GEAR PUMP**



**POMPA BOYUT ÖLÇÜLERİ / PUMP DIMENSIONS**

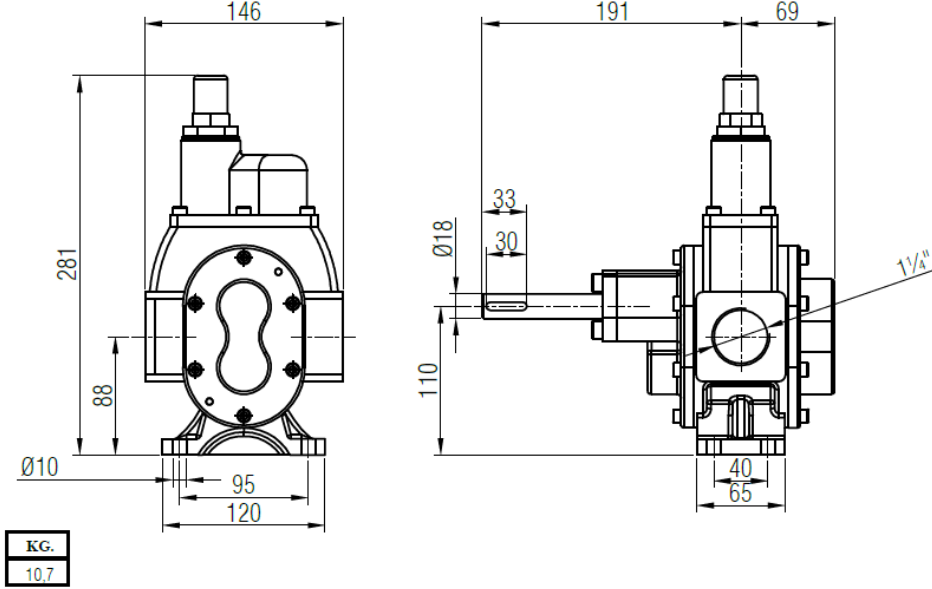

**AKUPLAJ ÖLÇÜLERİ / COUPLING DIMENSIONS**

**REDÜKTÖR AKUPELİ / GEARBOX DRIVE**

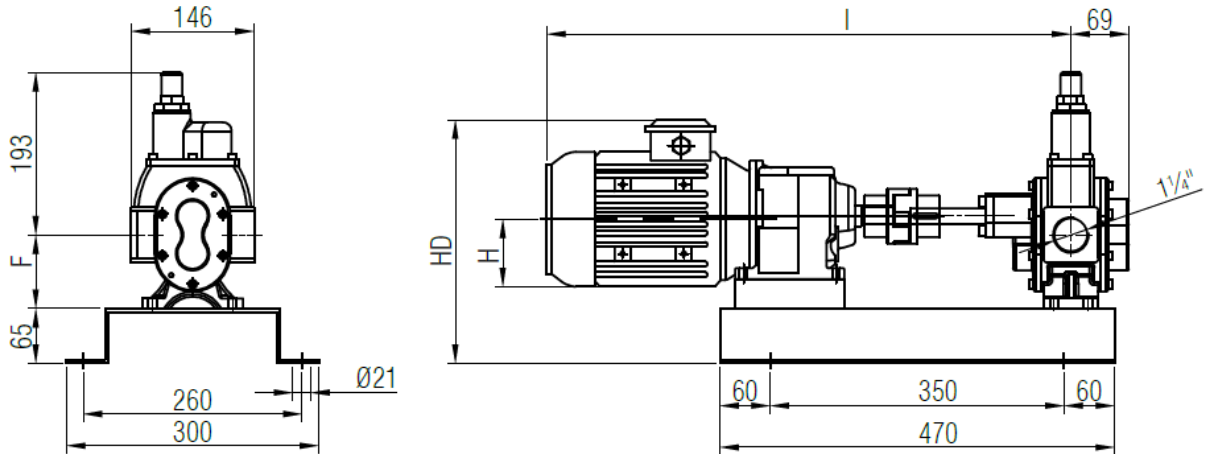

MOTOR GÜÇ VE DEVİRLERİ / MOTOR POWER AND SPEED			I	HD	H	kg.
0,75 hp / 0,55 kw	75/406 d/d (rpm)	IRAM42/80M	622	289	118	38
1 hp / 0,75 kw	40/240 d/d (rpm)	IRAM52/80M	656			44
2 hp / 1,5 kw	286/406 d/d (rpm)	IRAM42/90L	666	302	132	44
1,5 hp / 1,1 kw	60/380 d/d (rpm)	IRAM52/90S	675			47
2 hp / 1,5 kw	100/540 d/d (rpm)	IRAM52/90L	700	310	141	49
3 hp / 2,2 kw	175/540 d/d (rpm)	IRAM52/100L	729			53
4 hp / 3 kw	345/650 d/d (rpm)	IRAM52/100L		56		

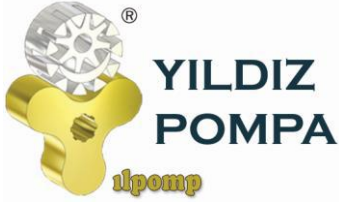

## YMDY 2 POMPA MODULAR GEAR PUMP



### AKUPLAJ ÖLÇÜLERİ / COUPLING DIMENSIONS

### MOTOR AKUPELİ / MOTOR DRIVE

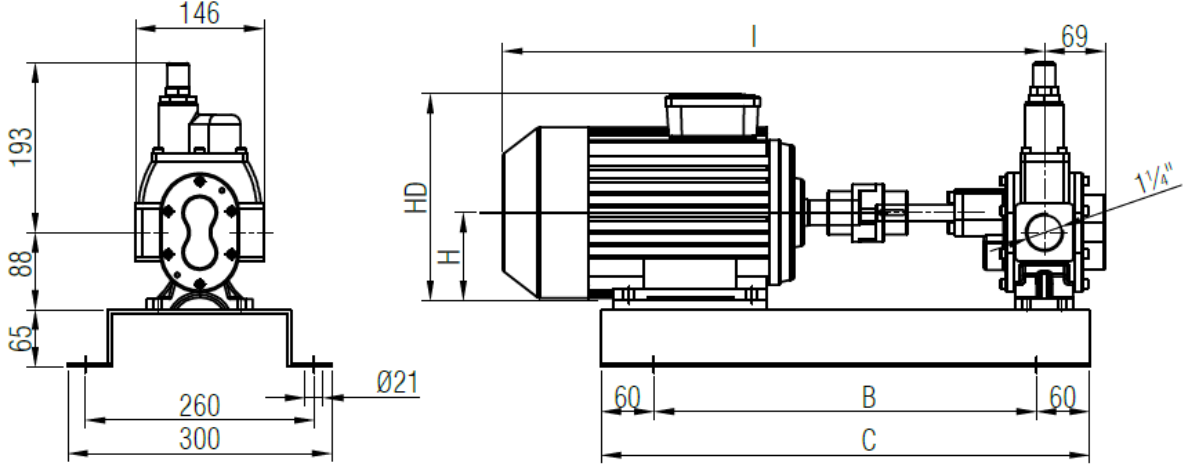

MOTOR GÜÇ VE DEVİRLERİ / MOTOR POWER AND SPEED			I	HD	H	B	C	D	E	F	kg.
0,5 hp / 0,37 kw	900 d/d (rpm)	MOTOR 80	487	293	80	350	470				30
0,75-1 hp / 0,55-0,75 kw	1400 d/d (rpm)										30 31
0,5 hp / 0,37 kw	750 d/d (rpm)	MOTOR 90S	516	301	90	380	500	260	300	88	34
1 hp / 0,75 kw	900 d/d (rpm)										33
1,5 hp / 1,1 kw	1400 d/d (rpm)	MOTOR 90L	568								34
1 hp / 0,55 kw	750 d/d (rpm)										36
1,5 hp / 1,1 kw	900 d/d (rpm)	MOTOR 100L	629	310	100	430	550				40 42
2 hp / 1,5 kw	1400 d/d (rpm)										42
1 -1,5 hp / 0,75 - 1,1 kw	750 d/d (rpm)	MOTOR 112M	605	322	112	420	620	310	350	90	40 43
2 hp / 1,5 kw	750 d/d (rpm)										56
3 - 4 hp / 2,2 - 3 kw	1400 d/d (rpm)										57
2 hp / 1,5 kw	900 d/d (rpm)										
3 hp / 2,2 kw	900 d/d (rpm)										
5,5 hp / 4 kw	1400 d/d (rpm)										



**YEDEK PARÇA LİSTESİ / SPARE PARTS LIST**

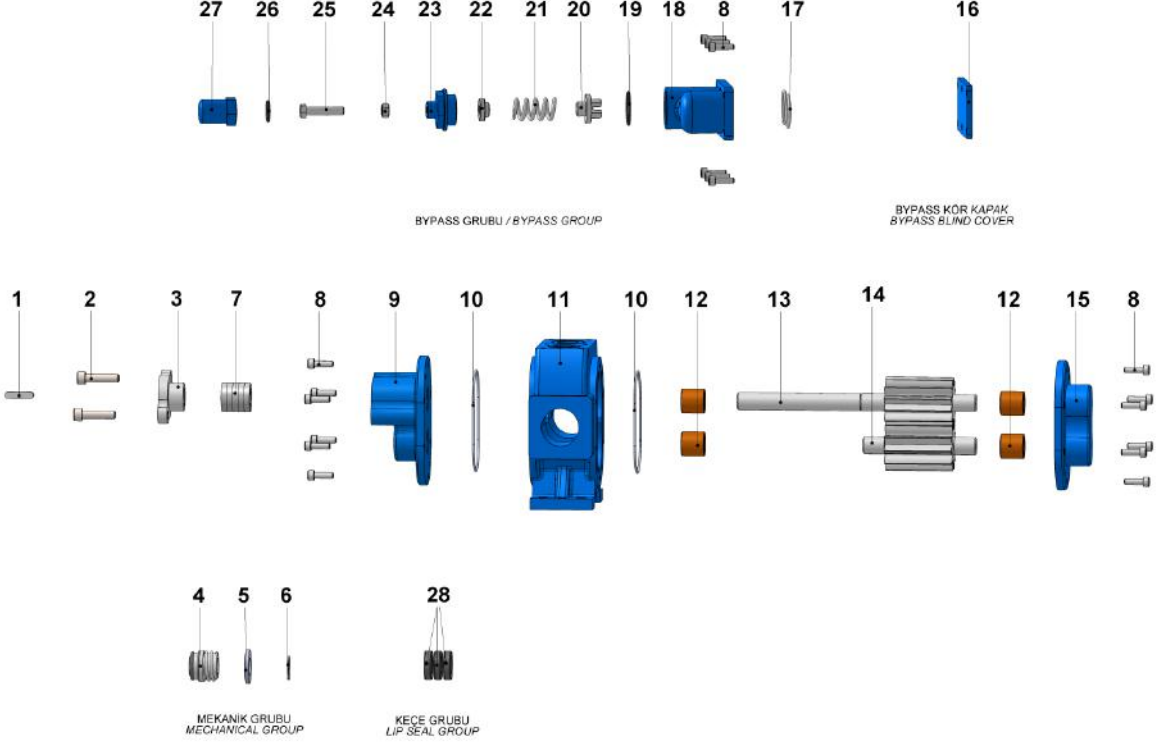

No	PARÇA İSMİ	PART NAME	ADET/ QTY	No	PARÇA İSMİ	PART NAME	ADET/ QTY
1	KAMA 6x6x30 A	COUPLING KEY 6x6x30 A	1	15	ARKA KAPAK	BACK COVER	1
2	M6x35 İMBUS CİVATA	IMBUS BOLT M6x35	2	16	BYPASS KÖR KAPAK	BYPASS INLETS COVER	1
3	YUMUŞAK SALMASTRA BASKISI	PACKING PRESS	1	17	BYPASS O-RING-2	BYPASS O-RING-2	1
4	MEKANİK SALMASTRA (ø18)	MECHANICAL SEAL (ø18)	1	18	BYPASS	PRESSURE RELIEF VALVE	1
5	MEKANİK PUL	MECHANICAL SEAL WASHER	1	19	BYPASS O-RING-1	BYPASS O-RING-1	1
6	18'LİK DIŞ SEGMAN	EXTERNAL CIRCLIP (ø18)	1	20	KLEPE	VALVE	1
7	YUMUŞAK SALMASTRA	SOFT SEAL / PACKING GLAND	4	21	YAY	SPRING	1
8	M6x20 İMBUS CİVATA	IMBUS BOLT M6x20	22	22	PUL	WASHER	1
9	ÖN KAPAK	FRONT COVER	1	23	BYPASS KAPAĞI	BYPASS COVER	1
10	GÖVDE O-RİNG	CASING O-RING	2	24	M8 SOMUN	NUT M8	1
11	GÖVDE	CASING	1	25	6 KÖŞE CİVATA M8x40	ADJUSTING SCREW M8x40	1
12	BURÇ	BUSHING-1	4	26	TIJ KAPAK O-RİNG	CAP O-RING	1
13	UZUN MİL	DRIVING SHAFT	1	27	TIJ KAPAĞI	CAP	1
14	KISA MİL	DRIVEN SHAFT	1	28	KEÇE ø18xø30x7	LIP SEAL ø18xø30x7	3