



YMD 1½ POMPA HIGH PRESSURE PUMP



POMPA DEĞERLERİ / PUMP PROPERTIES	
Q	:7,7 m ³ /h
Hm	:1 ~ 30 Bar
T	:0 ~ 100 °C
n	:1 ~ 1500 d/d
Visc.	:100 ~ 2500 SSU

KULLANIM ALANLARI

- Fuel Oil Servis Tankları, Gaz Yağı, Mazot Tankerlerinde
- Küçük çapta kızgın yağ sirkülasyonlarında
- Endüstrinin yarı viskoz mayilerinin pompaj işlemlerinde.
- Boya Sanayinde
- Gemi Sektörü

USE AREAS

- Fuel Oil Service Tanks, Gas Oil, Diesel-fuel Tanks.
- On a small scale hot oil circulations
- Half viscose liquids of industry are on pumping process
- Dye Industry
- Ship Sector

MALZEME SEÇENEKLERİ

- Pompa Gövdesi ve Kapaklar : Dökme (pik) demir, çelik döküm, paslanmaz AISI 304 / 316 döküm, sfero döküm
- Dişliler: Çelik, paslanmaz çelik AISI 304 / AISI 316
- Yataklar : Snbz 12 bronz, rulman, karbon grafit, ina burc
- Sızdırmazlık: Yumuşak salmastra, mekanik salmastra, keçe

MATERIAL OPTIONS

- Pump Body and covers: Cast iron, steel cast, stainless AISI 304 / 316 cast.
- Gears: Steel, stainless steel AISI 304 / AISI 316.
- Bearings: Snbz 12 bronze, bearing, carbon graphite, Ina bushing bearing.
- Sealing: Soft seal, mechanical seal, lip seal



YMD 1½ POMPA HIGH PRESSURE PUMP



MODÜL DİŞLİ POMPA ÇALIŞMA PRENSİBİ / WORKING PRINCIPLE OF MODULAR GEAR PUMP

Bu pompalar da dişli pompa prensibiyle çalışır. Pompa mili, motordan almış olduğu dairesel hareketi, mil üzerindeki dişli (çeviren) ile, diğer dişliye (çevrilen) ters yönde iletir. Dişliler birbirinden ayrılırken, dişlilerin arasına sıvı dolar. Bu sıvı, dönme hareketi ile basma bölgesine taşınarak, dişliler iç içe girerken basma kanalına atılır.

Sıvının viskozitesine bağlı olarak 40 Bar'a kadar basınç elde edilir. Korozif (Aşındırıcı) ve az hacimli akışkanın hızlı bir şekilde transfer edilmesini sağlar. Kompakt oldukları için güvenilirlik sunmaktadırlar.

These pumps operates according to the same principle of gear pumps'. Pump shaft transmits circular movement with its own gear (driving) to the other gear (driven) in opposite rotation direction. During suction, liquid fills gaps between gears' teeth. While in discharge, due to meshing between teeth of both gears rotation forces the liquid outside of outlet port.

40 Bar pressure could be generated depending on viscosity of the liquid. Corrosive and low volumes could be transferred in short time. Reliability is provided thanks to pumps compact design.

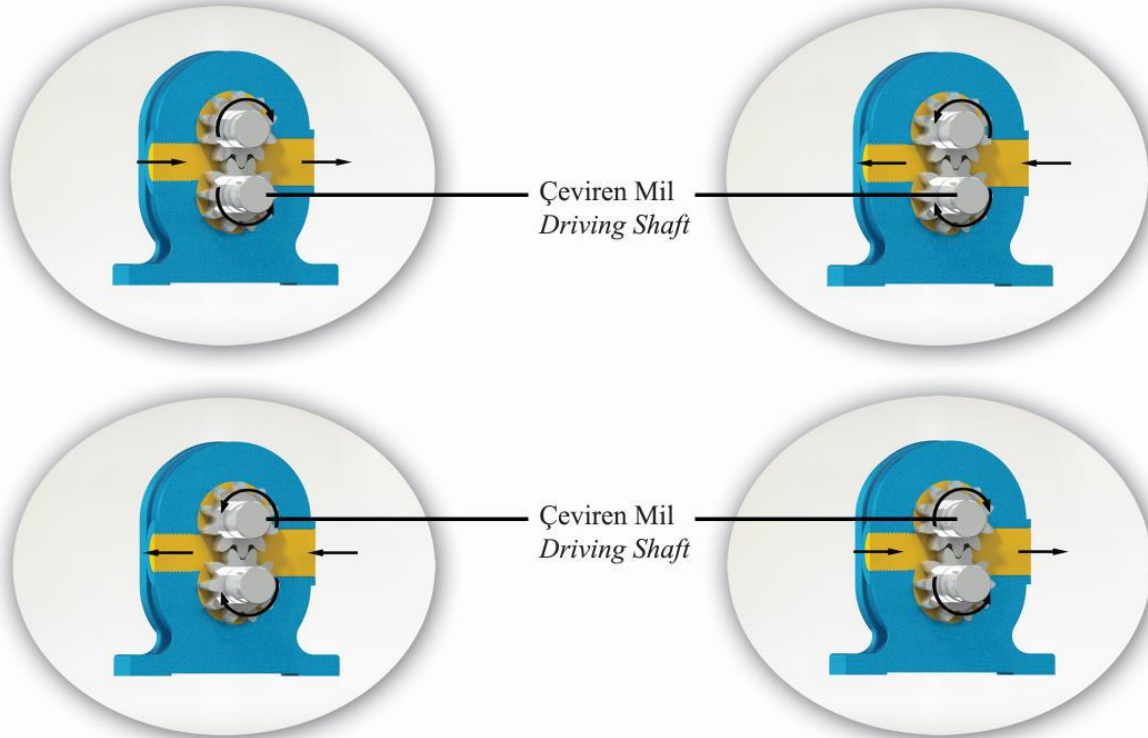

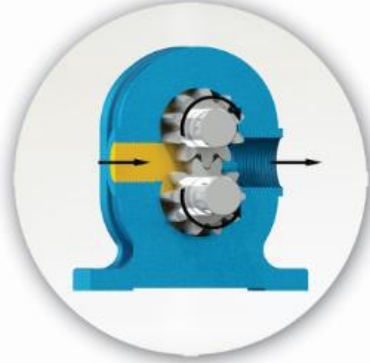

Yandaki renkli kısım sıvının pompa gövdesindeki emiş ağız alanına, çeviren ve çevrilen dişlilerin dişli boşlukları alanına girişini gösterir. Siyah oklar pompanın dönüş ve sıvının ilerleyişini gösterir.

In this picture, liquid is illustrated while filling suction port and gaps between gears' teeth. Black arrows shows rotation direction and forwarding of the liquid.

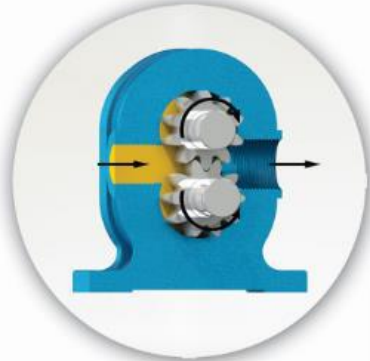

Görüldüğü gibi akışkan taşınması dişliler ile dişlileri içinde barındıran gövde arasında olmaktadır. Akışkan dişliler arasından geçmemektedir.

As shown, transferring of the liquid is done by casing and gears within it. Liquid is not passing in between gears.

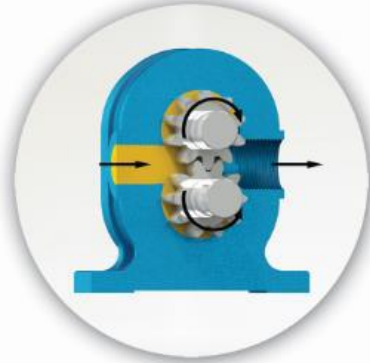

Bu resim pompanın iç kısmının dolup sıvının boşaltma ağız alanına itilmesinden hemen önceki durumunu göstermektedir. Çeviren ve çevrilen modül dişlilerin diş boşluklarının sıvı için nasıl bir kapalı cep oluşturduğuna ve bunun tam bir hacim kontrolü sağlanmasını nasıl garantilediğine dikkat ediniz.

This picture shows the situation of the liquid filling pump inner side and just right before passing to discharge area. Pay attention how driving and driven gears guarantees volume control and a closed area for the liquid.

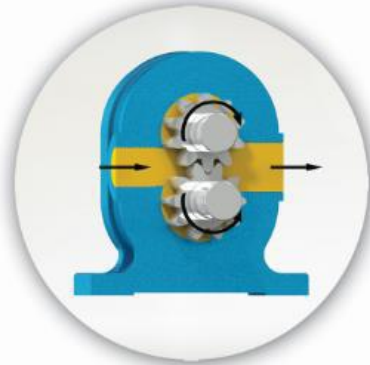

Bu görüntü pompanın tamamen dolup taşıdığı durumu ve sıvının boşaltma işlemini, boşaltma ağızından ilerleyişini göstermektedir. Sonunda birbirine geçen dişlilerin gücü ile akışkan basınç altında çıkış ağızına iletilir.

Picture here shows liquid discharge process and forwarding. Pressure gained due to meshing for teeth forces the liquid to the outlet port.



YMD1½ POMPASINA AİT KAPASİTE VE GÜÇ TABLOSU / CAPACITY AND POWER TABLE							
KAPASİTE (m³/h) CAPACITY (Q)	DEVİR (d/d) SPEED (rpm)	ÇIKIŞ BASINCI / PRESSURE			VİSKOZİTE VISCOSITY		
		0 Bar	3,5 Bar	7 Bar			
2,7	500	3 HP	4 HP	4 HP	2500 SSU		
3,8	750	4 HP	4 HP	5,5 HP	2500 SSU		
4,8	900	4 HP	4 HP	5,5 HP	750 SSU		
6	1400	4 HP	5,5 HP	5,5 HP	100 SSU		
MOTOR GÜÇLERİ MOTOR POWERS		MOTOR GÜÇLERİ MOTOR POWERS		MOTOR GÜÇLERİ MOTOR POWERS		MOTOR GÜÇLERİ MOTOR POWERS	
4 HP	1400 d/d (rpm)	5,5 HP	1400 d/d (rpm)	4 HP	750 d/d (rpm)	5,5 HP	750 d/d (rpm)
MOTOR GÖVDESİ MOTOR BODY		MOTOR GÖVDESİ MOTOR BODY		4 HP	900 d/d (rpm)	MOTOR GÖVDESİ MOTOR BODY	
100		112		5,5 HP	900 d/d (rpm)	160	
				MOTOR GÖVDESİ MOTOR BODY			
				132			

YMD1½ pompada bypass max. 10 bar için kullanılmaktadır.
Capable of handling pressure up to 10 Bar on YMD1½ pump's bypass.

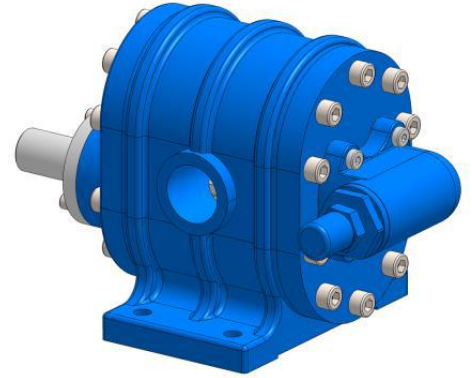
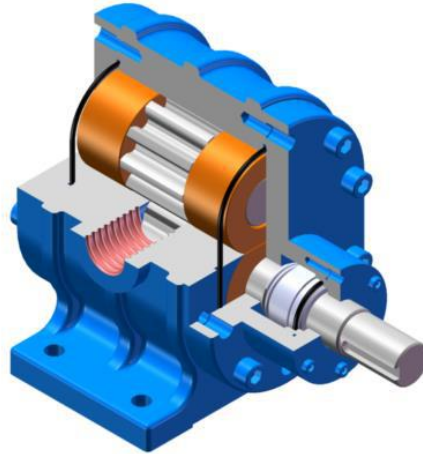



KAPASİTE EĞRİLERİ / CAPACITY GRAPHS

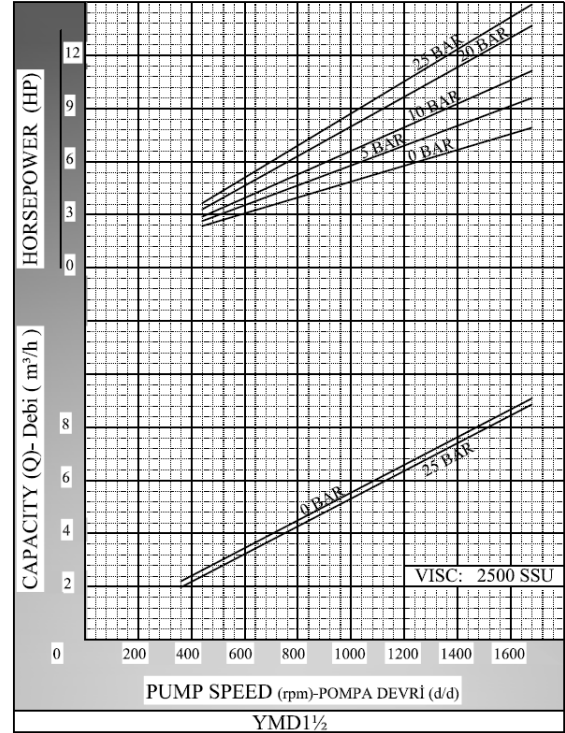
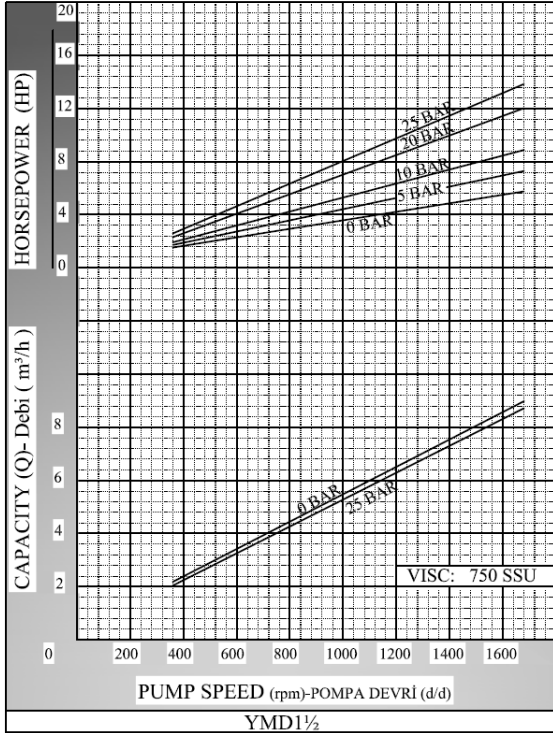
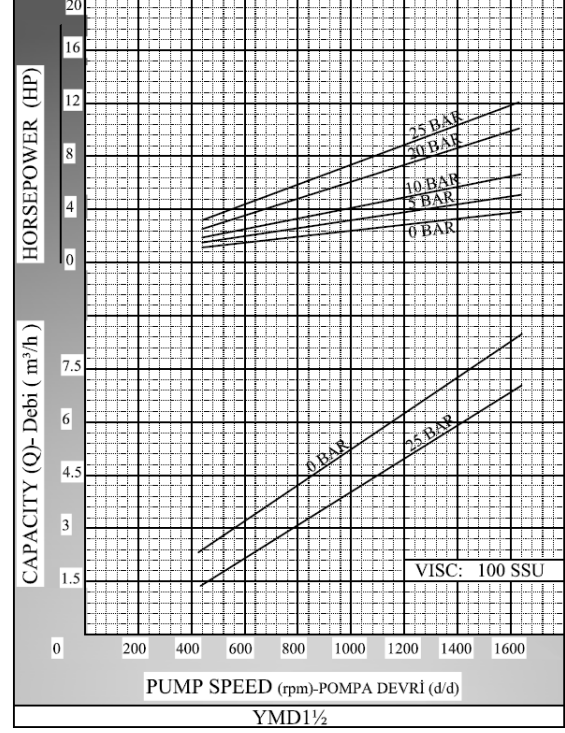
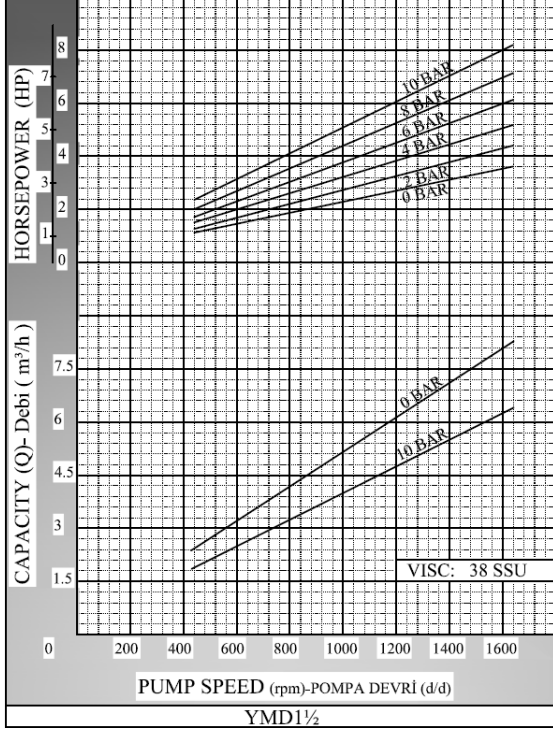



**YILDIZ
POMPA**

**YMD 1½ POMPA
HIGH PRESSURE PUMP**



POMPA BOYUT ÖLÇÜLERİ / PUMP DIMENSIONS

30 BAR'A KADAR YÜKSEK BASINÇ İÇİN
STANDART GİRİŞ 1½" – ÇIKIŞ 1"
OPSIYONEL GİRİŞ 1½" - ÇIKIŞ 1"
10 BAR'A KADAR, DÜŞÜK BASINÇ İÇİN
STANDART GİRİŞ 1½" – ÇIKIŞ 1½"
OPSIYONEL GİRİŞ 1½" – ÇIKIŞ 1½"

FOR HIGH PRESSURE UP TO 30 BAR,
STANDARD INLET 1½" – OUTLET 1"
OPTIONAL INLET 1½" – OUTLET 1"
FOR LOW PRESSURE UP TO 10 BAR,
STANDARD INLET 1½" – OUTLET 1½"
OPTIONAL INLET 1½" – OUTLET 1½"

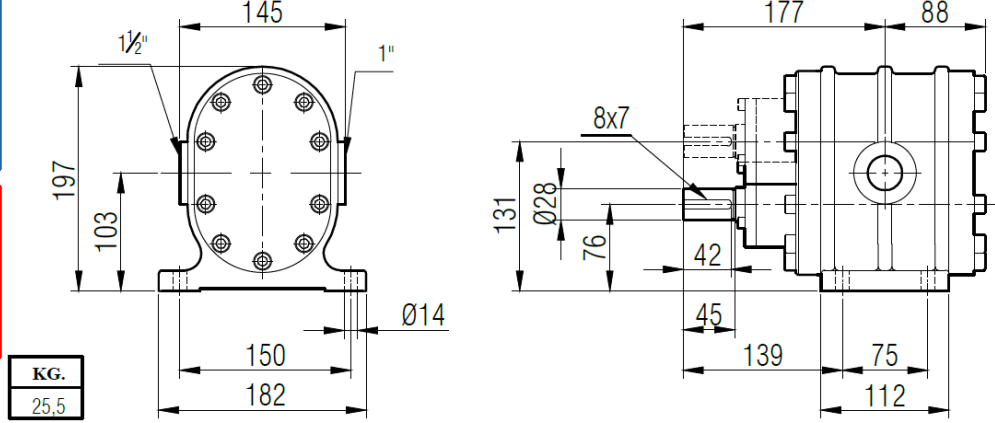

CEKETLİ / WITH JACKETED COVER

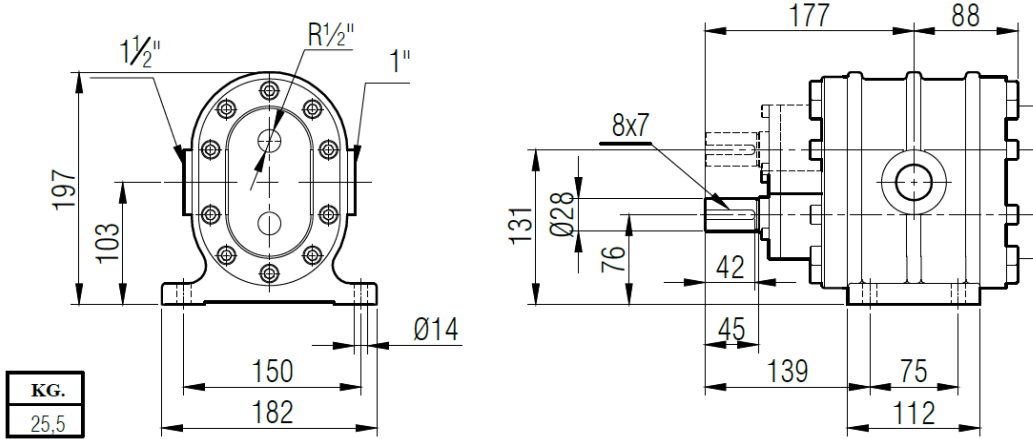

BYPASSLI / PRESSURE RELIEF VALVE ON COVER

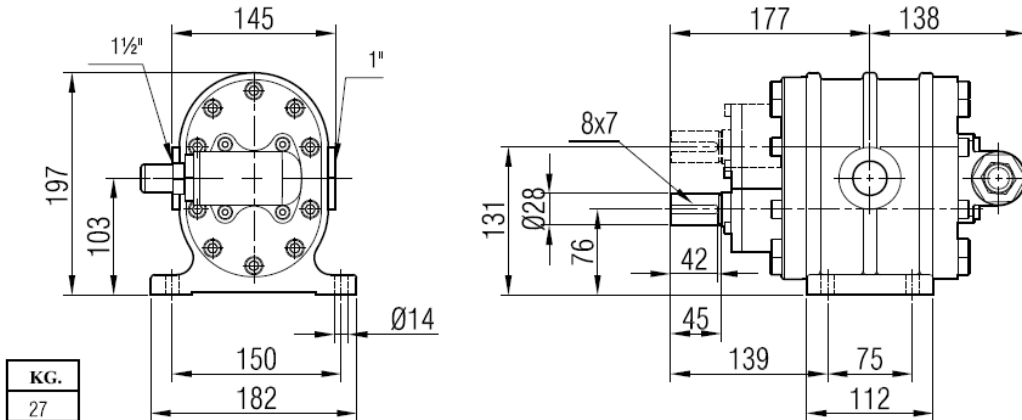

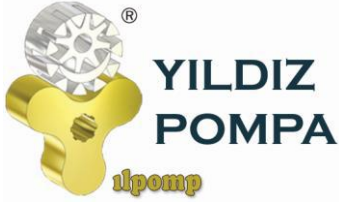

YMD 1½ POMPA HIGH PRESSURE PUMP



AKUPLAJ ÖLÇÜLERİ / COUPLING DIMENSIONS

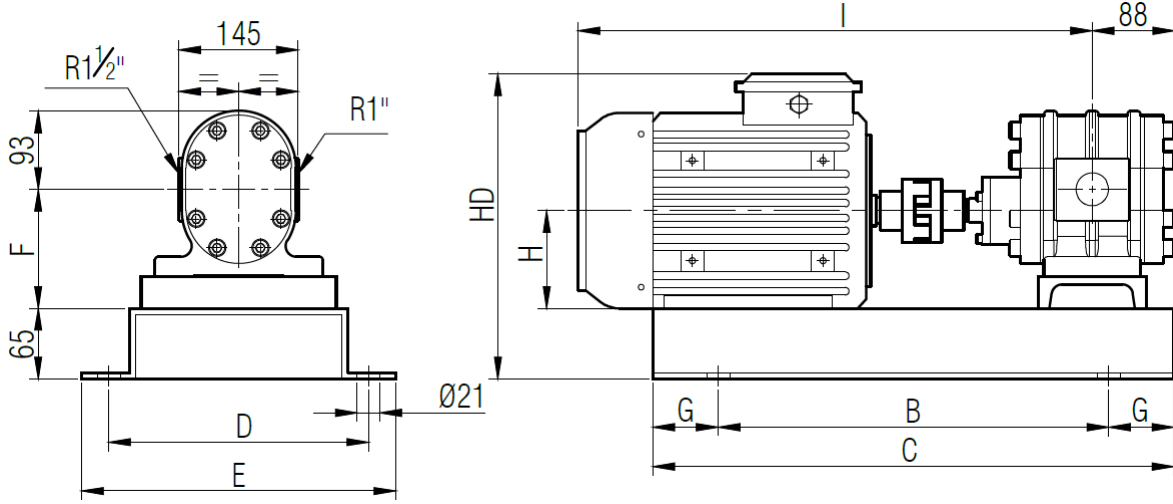

MOTOR GÜÇ VE DEVİRLERİ / MOTOR POWER AND SPEED			I	HD	H	B	C	D	E	F	G	kg.
2 hp / 1.5 kw	1400 d/d (rpm)	MOTOR 90L	554	281	90	430	550	260	300	117	60	53
2 hp / 1.5 kw	900 d/d (rpm)	MOTOR 100L	604	300	100	420	620	310	350	128	63	65
3 - 4 hp / 2.2 - 3 kw	1400 d/d (rpm)											67
2 hp / 1.5 kw	750 d/d (rpm)	MOTOR 112M	619	323	112	420	620	310	350	140	100	73
3 hp / 2.2 kw	900 d/d (rpm)											74
5.5 hp / 4 kw	1400 d/d (rpm)	MOTOR 132S	658	365	132	500	700	310	350	159	100	82
3 hp / 2.2 kw	750 d/d (rpm)											83
4 hp / 3 kw	900 d/d (rpm)	MOTOR 132M	704	365	132	500	700	310	350	159	100	87
7.5 hp / 5.5 kw	1400 d/d (rpm)											90
4 hp / 3 kw	750 d/d (rpm)	MOTOR 160M	804	450	160	580	780	380	420	187	100	94
5.5 hp / 4 kw	900 d/d (rpm)											97
10 hp / 7.5 kw	1400 d/d (rpm)	MOTOR 160M	804	450	160	580	780	380	420	187	100	128
5.5 hp / 4 kw	750 d/d (rpm)											139
10 hp / 7.5 kw	900 d/d (rpm)											145
15 hp / 11 kw	1400 d/d (rpm)											

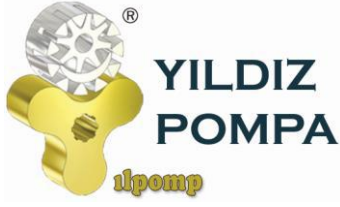

YMD 1½ POMPA HIGH PRESSURE PUMP



YEDEK PARÇA LİSTESİ / SPARE PARTS LIST KEÇELİ VE MEKANİK SALMASTALI / LIP SEAL & MECHANICAL SEAL

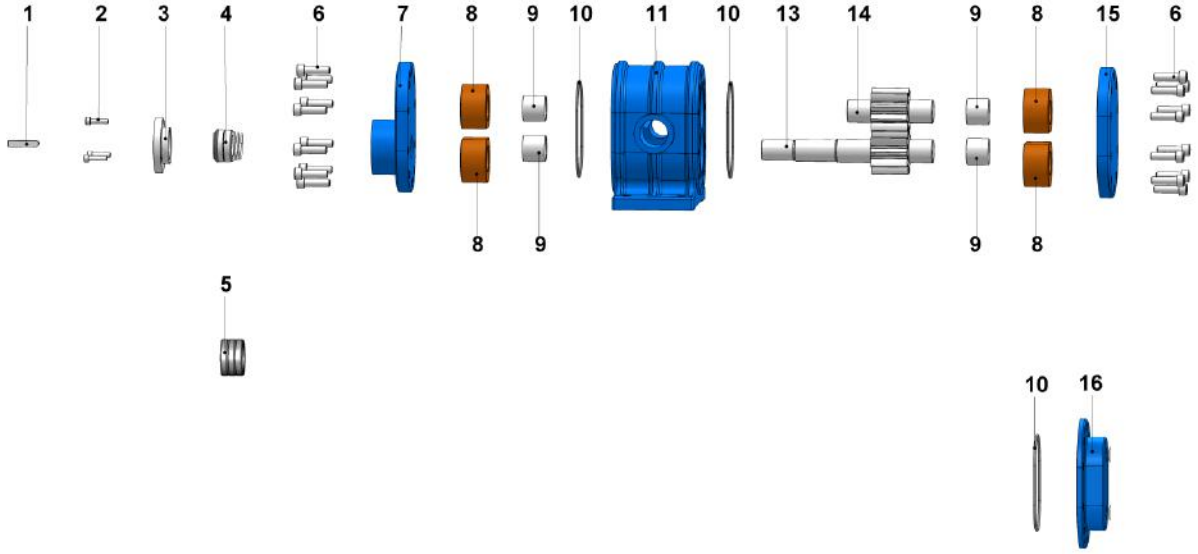

No	PARÇA İSMİ	PART NAME	ADET/ QTY.
1	KAPLIN KAMA 8x7x42AB	COUPLING KEY 8x7x42AB	1
2	IMBUS CİVATA M6x25	IMBUS BOLT M6x25	3
3	SALMASTRA KAPAĞI	SEAL COVER	1
4	MEKANİK SALMASTRA Ø30	MECHANICAL SEAL Ø30	1
5	KEÇE Ø30xØ50x10	LIP SEAL Ø30xØ50x10	3
6	M10x35 İMBUS CİVATA	IMBUS BOLT M10x35	20
7	ÖN KAPAK	FRONT COVER	1
8	BURC	BUSHING	4
9	İNA BURC	INA BURC	4
10	GÖVDE O-RİNG Ø108xØ3	CASING O-RING Ø108xØ3	2
11	GÖVDE	CASING	1
13	UZUN MİL	DRIVING SHAFT	1
14	KISA MİL	DRIVEN SHAFFT	1
15	ARKA KAPAK	BACK COVER	1
16	KAPAK (CEKETLİ)	COVER (w/ HEATING JACKET)	1



YEDEK PARÇA LİSTESİ / SPARE PARTS LIST
KEÇELİ VE MEKANİK SALMASTALI / LIP SEAL & MECHANICAL SEAL

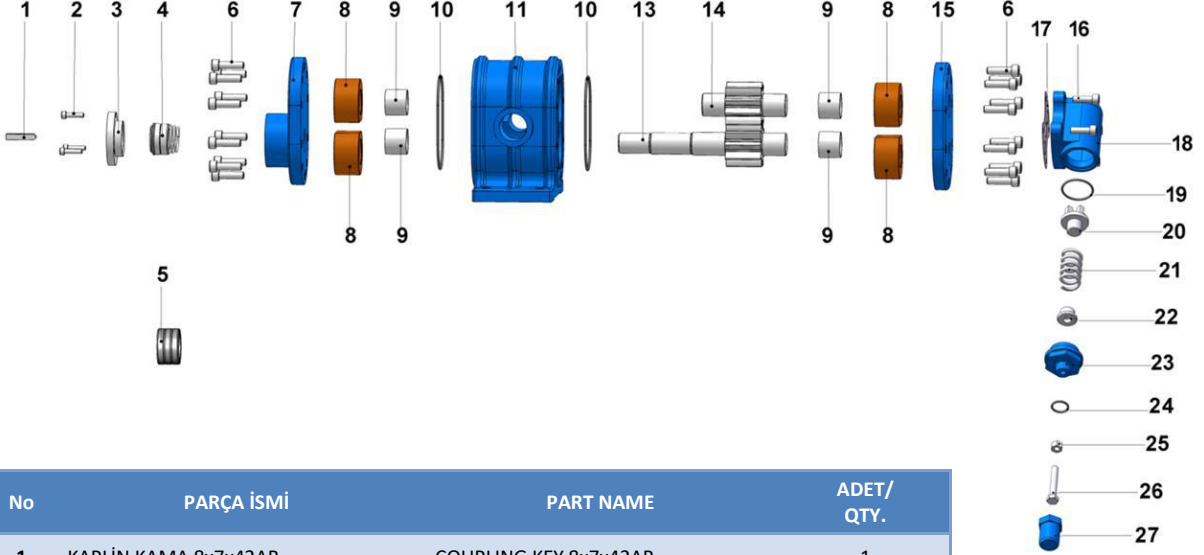

No	PARÇA İSMİ	PART NAME	ADET/ QTY.
1	KAPLİN KAMA 8x7x42AB	COUPLING KEY 8x7x42AB	1
2	İMBUS CİVATA M6x25	İMBUS BOLT M6x25	3
3	SALMASTRA KAPAĞI	SEAL COVER	1
4	MEKANİK SALMASTRA Ø30	MECHANICAL SEAL Ø30	1
5	KEÇE Ø30xØ50x10	LIP SEAL Ø30xØ50x10	3
6	M10x35 İMBUS CİVATA	İMBUS BOLT M10x35	20
7	ÖN KAPAK	FRONT COVER	1
8	BURC	BUSHING	4
9	İNA BURC	İNA BURC	4
10	GÖVDE O-RİNG Ø108xØ3	CASING O-RING Ø108xØ3	2
11	GÖVDE	CASING	1
13	UZUN MİL	DRIVING SHAFT	1
14	KISA MİL	DRIVEN SHAFFT	1
15	ARKA KAPAK	BACK COVER	1
16	İMBUS CİVATA M8x25	İNBUS BOLT M8x25 FOR COVER	4
17	BYPASS CONTASI	BYPASS GASKET	1
18	BYPASS	PRESSURE RELIEF VALVE – BYPASS	1
19	BYPASS O-RING	BYPASS O-RING	1
20	KLEPE	VALVE	1
21	YAY	SPRING	1
22	PUL	WASHER	1
23	BYPASS KAPAĞI	BYPASS COVER	1
24	TİJ KAPAK O-RİNG	CAP O-RING	1
25	M8 SOMUN	NUT M8	1
26	6 KÖŞE CİVATA M8x55	ADJUSTING SCREW M8x55	1
27	TİJ KAPAĞI	CAP	1