

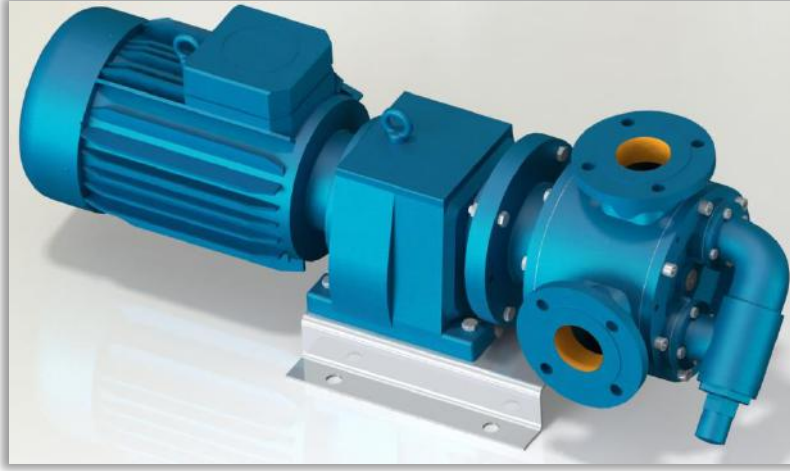

## YMBUF2½" POMPA INTERNAL ECCENTRIC GEAR PUMP



### POMPA DEĞERLERİ / PUMP PROPERTIES

|       |                        |
|-------|------------------------|
| Q     | : 32 m <sup>3</sup> /h |
| Hm    | :1 ~ 5 Bar             |
| T     | :0 ~ 70 °C             |
| n     | :400 d/d               |
| Visc. | :100 ~ 25.000 SSU      |

### KULLANIM ALANLARI

- Fuel Oil Servis Tankları, Gaz Yağı, Mazot Tankerlerinde
- Kağıt ve Boya Sanayinde,
- Küçük çapta kızgın yağ sirkülasyonlarında
- İlaç, kimya ve deterjan sanayinde,
- Gıda Sanayinde.

### USE AREAS

- Fuel Oil Service Tanks, Gasoil, Diesel Tankers
- Paper and Paint/dye industry
- Circulation of Hot Oil (limited)
- Medicine, Chemical and Detergent Industry
- Food Industry.

### MALZEME SEÇENEKLERİ

- Pompa Gövdesi, Kapaklar : Dökme (pik) demir, çelik döküm, paslanmaz AISI 304 / 316 döküm
- Dişliler : Dökme (pik) demir, çelik döküm, paslanmaz AISI 304 / 316 döküm, sfero döküm
- Yataklar : Snbz 12 bronz, karbon grafit, Silisyum Karbür, Sert Metal Kaplama
- Sızdırmazlık: Keçeli Sistem

### MATERIAL OPTIONS

- Pump Body, covers : Cast iron, steel cast, stainless AISI 304 / 316 cast.
- Gears : Cast iron, steel cast, stainless AISI 304 / 316 cast, Spheroidal cast iron.
- Bearings: Snbz 12 bronze, carbon graphite, silicon carbide, hard metal coated steel.
- Sealing: Lip seal



## YMBUF2½" POMPA INTERNAL ECCENTRIC GEAR PUMP



### İÇTEN EKSANTİK DİŞLİ POMPA ÇALIŞMA PRENSİBİ / WORKING PRINCIPLE OF INTERNAL ECCENTRIC GEAR PUMP

Yıldız Pompa' nın "dişli içinde dişli" prensibinde sadece iki tane hareketli parça vardır. Bütün pozitif deplasmanlı YILDIZ dişli pompalarının güvenilir ve verimli çalışmasının sırrı budur. Sıvının pozitif deplasmanı (yer değiştirmesi) rotor ve avare dişlisinin dişleri arasındaki boşluğun komple dolmasıyla sağlanmaktadır. Bütün dişli pompalarda olduğu gibi, YILDIZ POMPA' da da performansın en üst noktaya çıkmasını sınırlayıcı yegane faktör, pompalanan sıvının diğerlerine göre daha temiz olmasını istemesidir.

Pompa milinin her devrinde emiş ağzı yoluyla belli bir miktar sıvı pompaya girer. Bu sıvı rotor ile avare dişlisi arasındaki boşluğu doldurur. Pompa kapağında bulunan hilal, çıkış ağzına doğru pürüzsüz şekilde hareket eden sıvının akışını ayırır. Kendi dişleri ile hilalin iç yüzeyi arasında sıvıyı taşıyan avare dişlisi pompa kapağının desteklediği bir mil üzerinde döner. Dişleri arasında sıvıyı taşıyan rotor dişlisi pompa gövdesi ile hilalin dış yüzeyi arasında hareket eder ve pompa miline bağlıdır.

*YILDIZ's simple "gear-within a gear" principle has only two moving parts. It is the secret of dependable, efficient operation of all positive displacement YILDIZ POMPA's PUMPS. The positive displacement of liquid is accomplished by the complete filling of the spaces between the teeth of the rotor and idler gears. The only limiting factor to peak performance in YILDIZ POMPA, as with all rotary pumps, is that the liquid pumped must be comparatively clean.*

*With every revolution of the pump's shaft, a definite amount of liquid enters the pump through the suction port. This liquid fills the spaces between the teeth of the rotor and the idler. The crescent on the pump head splits the flow of liquid as it moves smoothly towards the discharge port. The idler gear, which carries the liquid between its teeth and the inside surface of the crescent is connected to pump cover. On the otherhand, rotor gear which is rotated directly with pump shaft delivers the liquid between gear teeth and crescent's souter surface.*

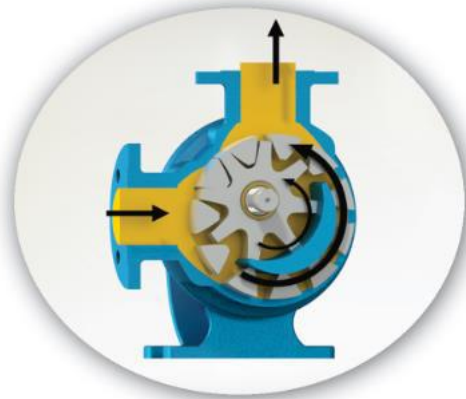
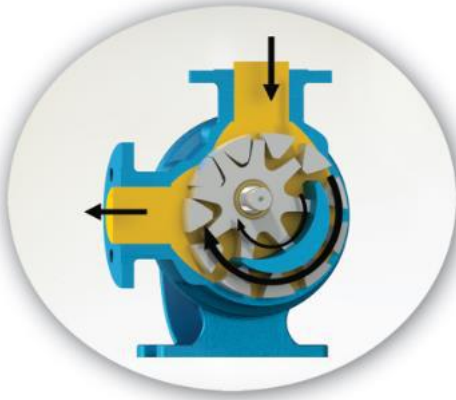

## YMBUF2½" POMPA INTERNAL ECCENTRIC GEAR PUMP



Yandaki renkli kısım sıvının pompa gövdesindeki emiş ağızı alanına, rotor dişlisi ve avare dişlisi dişleri arasındaki dişli boşlukları alanına girişini gösterir. İki siyah ok pompanın dönüş ve sıvının ilerleyişini gösterir.

*The yellow colored portion at side indicates the liquid as it enters the suction port area of the casing and the area between the rotor teeth and corresponding concave area between the idler teeth. The two black arrows indicate the pump rotation and progress of the liquid.*



"Dişli içinde dişli" prensibinde çalışan dişliler ile pompa içinde sıvının ilerleyişine dikkat edin. Aynı zamanda, pompa kapağı üzerindeki hilal şeklinin sıvıyı nasıl böldüğüne ve emiş ile boşaltma ağızları arasında bir keçe (conta) gibi vazife gördüğüne dikkat ediniz.

*Notice the progress of the liquid through the pump and between the teeth of rotor idler gear. Also, note how the crescent shape on the head divides the liquid and acts as a seal between the suction and discharge ports.*



Bu resim pompanın iç kısmının dolup sıvının boşaltma ağızı alanına itilmesinden hemen önceki durumunu göstermektedir. Avare ve rotor dişlilerinin dizaynının sıvı için nasıl bir kapalı cep oluşturduğuna ve bunun tam bir hacim kontrolü sağlanmasını nasıl garantilediğine dikkat ediniz.

*This illustration shows the pump in a nearly flooded condition just previous to the liquid being forced into the discharge port area. Notice how the gear design of the idler and rotor form locked pockets for the liquid to guarantee absolute volume control.*



Bu görüntü pompanın tamamen dolup taşıdığı durumu ve sıvının boşaltma işlemini, boşaltma ağızından ilerleyişini göstermektedir. Emiş ve boşaltma ağızlarına eşit mesafede sızdırmaz bir keçe oluşturan, sıvıyı boşaltma ağızından dışarı doğru iten, rotor ve avare dişlisinin dişleri birbiri içine geçer.

*The view shows the pump in a completely flooded condition and in the process of discharging the liquid through discharge port. The rotor and idler teeth mesh, forming a seal equidistant between the both ports, forcing liquid out the discharge port.*





## YMBUF2½" POMPA INTERNAL ECCENTRIC GEAR PUMP



| YMBU-2½" - YMBUF-2½" - YMBUYF-2½" POMPASINA AİT<br>KAPASİTE VE GÜÇ TABLOSU / CAPACITY AND POWER TABLE |                            |                          |       |       |                        |
|---|----------------------------|--------------------------|-------|-------|------------------------|
| KAPASİTE (m³/h)<br>CAPACITY (Q)   | DEVİR (d/d)<br>SPEED (rpm) | ÇIKIŞ BASINCI / PRESSURE |       |       | VİSKOZİTE<br>VISCOSITY |
|   |                            | 2 Bar                    | 3 Bar | 5 Bar |                        |
| 16  | 200                        | 7,5 HP                   | 10 HP | 10 HP | 75.000 SSU             |
| 22  | 280                        | 7,5 HP                   | 10 HP | 15 HP | 25.000 SSU             |
| 27  | 350                        | 7,5 HP                   | 10 HP | 15 HP | 7.500 SSU              |
| 32  | 400                        | 7,5 HP                   | 10 HP | 15 HP | 2.500 SSU              |



### KAPASİTE EĞRİLERİ / CAPACITY GRAPHS

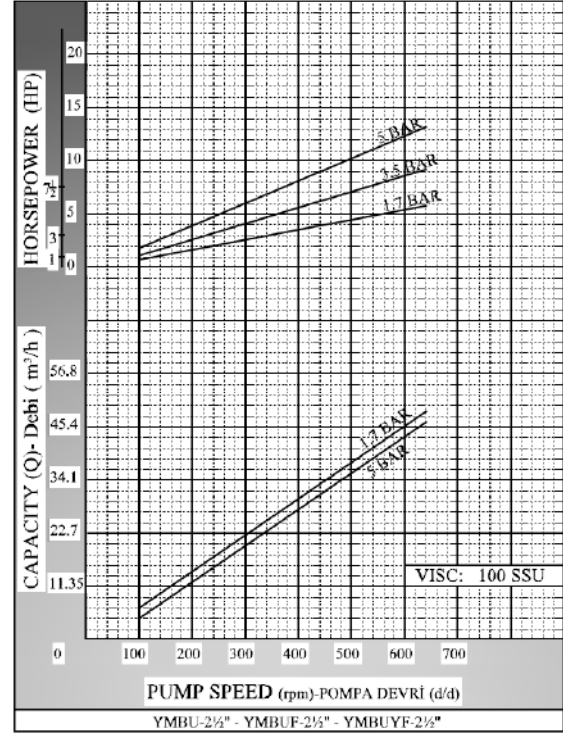
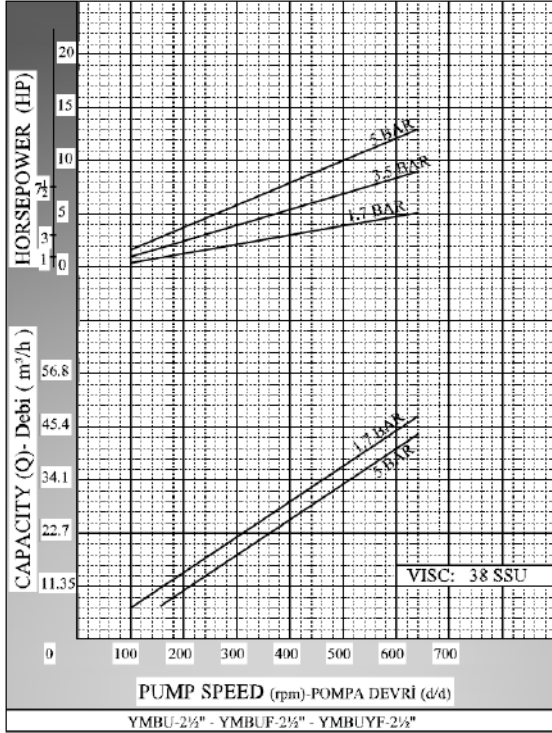



**YILDIZ  
POMPA**

ilpomp

**YMBUF2½" POMPA  
INTERNAL ECCENTRIC  
GEAR PUMP**

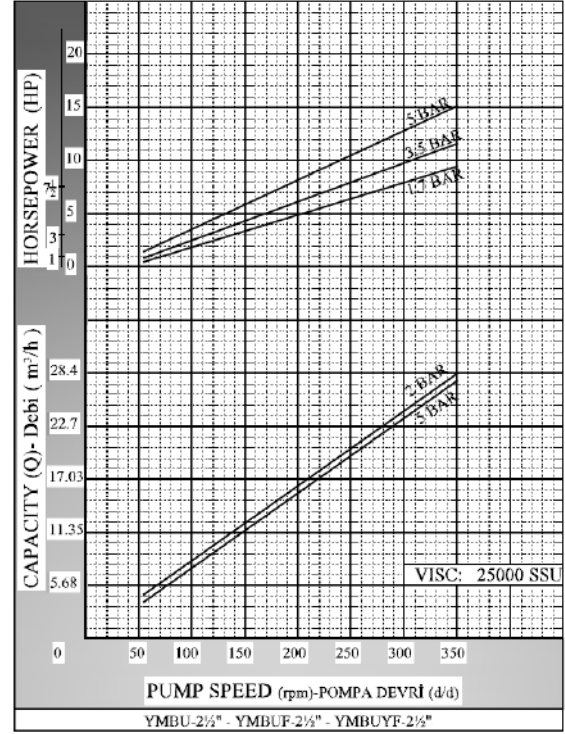
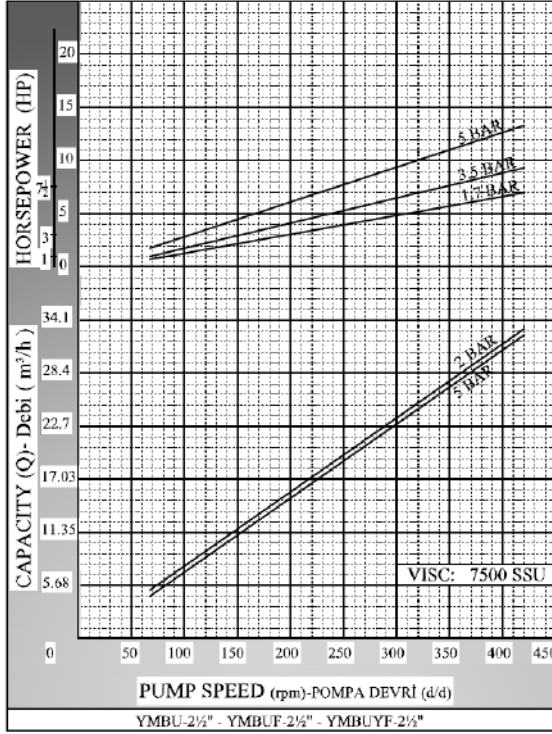
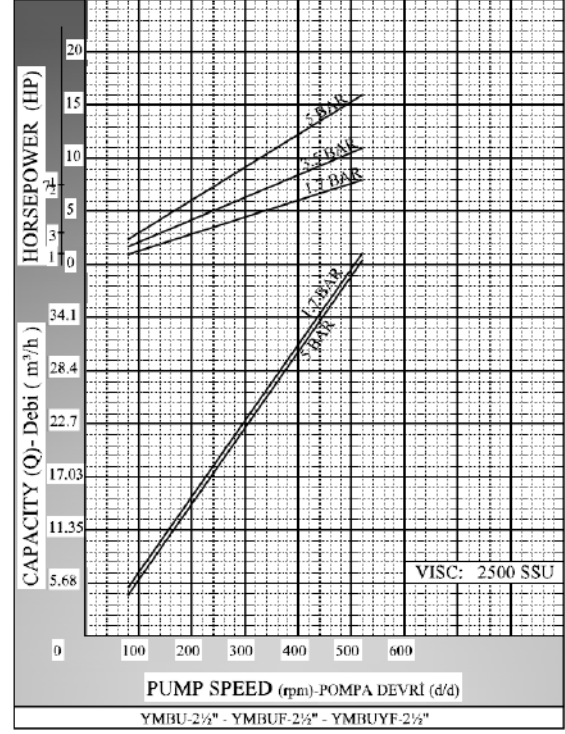
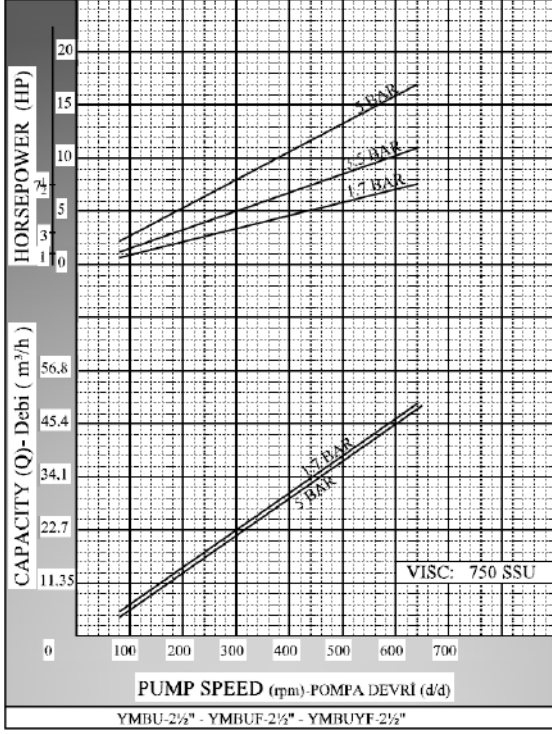





## YMBUF2½" POMPA INTERNAL ECCENTRIC GEAR PUMP



### POMPA BOYUT ÖLÇÜLERİ / PUMP DIMENSIONS

YMBUF 2½"

YMBU 2½"

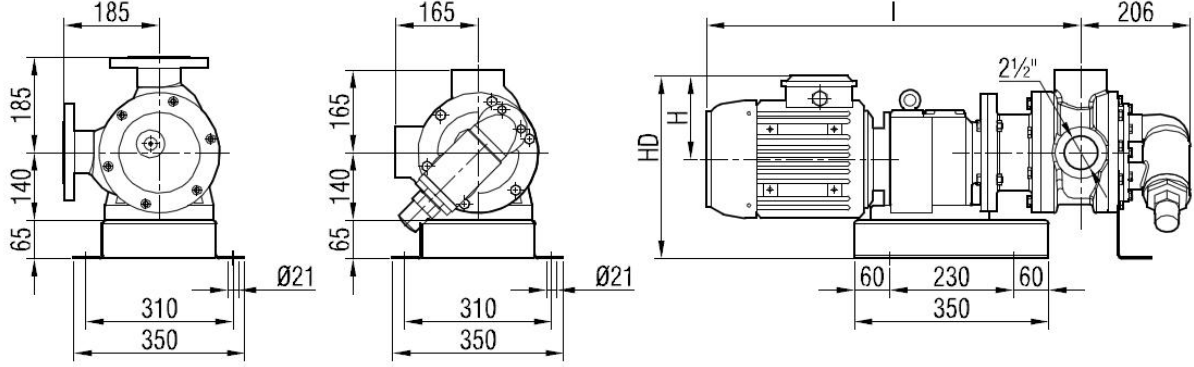

YMBUYF 2½"

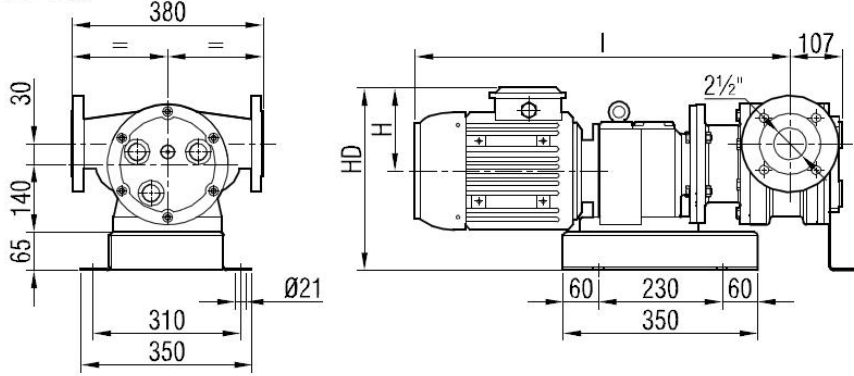

| MOTOR GÜÇ VE DEVİRLERİ /<br>MOTOR POWER AND SPEED   | I   | HD  | H   | kg.     |
|---|-----|-----|-----|---------|
| 3 -4 hp / 2,2 -3 kw<br>65/450 d/d(rpm) IRAFM62/100L | 701 | 335 | 141 | 123 131 |
| 5,5 hp / 4 kw<br>87/450 d/d(rpm) IRAFM62/112M       | 722 | 343 | 149 | 133     |
| 7,5 hp / 5,5 kw<br>70/400 d/d(rpm) IRAFM72/132S     | 800 | 371 | 182 | 156     |
| 10 hp / 7,5 kw<br>120/400d/d(rpm) IRAFM72/132M      | 846 |     |     | 167     |

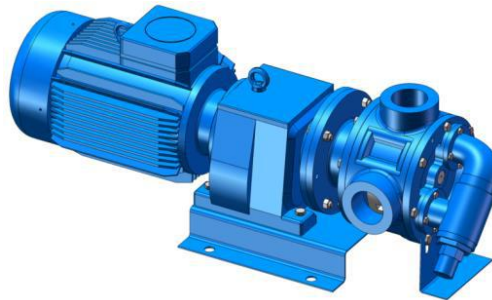
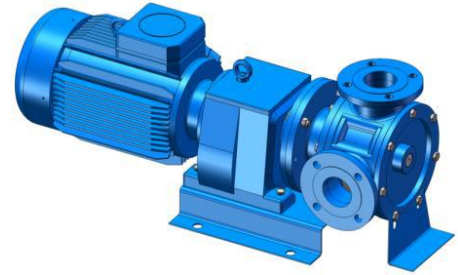



## YMBUF2½" POMPA INTERNAL ECCENTRIC GEAR PUMP



### YEDEK PARÇA LİSTESİ / SPARE PARTS LIST KEÇELİ VE BYPASSLI / SEALED WITH LIP SEAL, AND PRESSURE RELIEF VALVE ON COVER

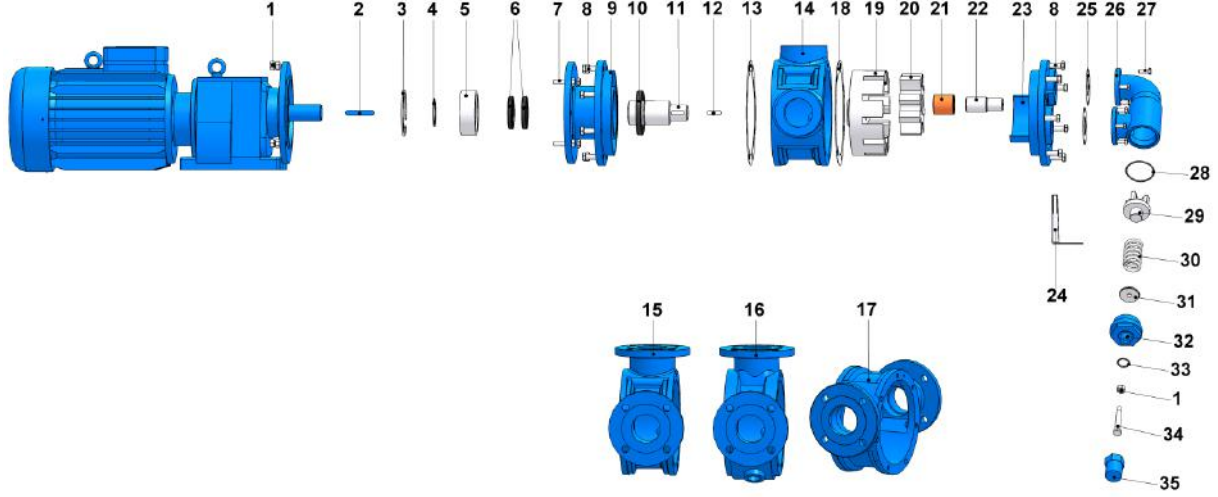

| No | PARÇA İSMİ                         | PART NAME   | ADET/<br>QTY. | No | PARÇA İSMİ              | PART NAME                   | ADET/<br>QTY. |
|----|------------------------------------|---|---------------|----|-------------------------|-----------------------------|---------------|
| 1  | M12 SOMUN                          | NUT M12   | 4             | 19 | ÇEVRE DİŞLİ             | ROTOR GEAR                  | 1             |
| 2  | KAMA 12x8x70 A                     | GEARMOTOR KEY 12x8x70 A                           | 1             | 20 | AVARA DİŞLİ             | IDLER GEAR                  | 1             |
| 3  | İÇ SEGMAN (ø110)                   | INTERNAL CIRCLIP (ø110)                           | 1             | 21 | AVARA DİŞLİ<br>BURCU    | IDLER BUSHING               | 1             |
| 4  | DIŞ SEGMAN (ø60)                   | EXTERNAL CIRCLIP (ø60)                            | 1             | 22 | KAPAK MİLİ              | COVER PIN                   | 1             |
| 5  | RULMAN (3212-2RS)                  | BALL BEARING (3212-2RS)                           | 1             | 23 | KAPAK (BYPASSLI)        | COVER (w/ BYPASS<br>INLETS) | 1             |
| 6  | KEÇE ø60xø80x10                    | LIP SEAL ø60xø80x10                               | 2             | 24 | POMPA AYAK              | PUMP SUPPORT                | 1             |
| 7  | 6 KÖŞE CİVATA M12x45               | SCREW M12x45                                      | 4             | 25 | BYPASS CONTASI          | BYPASS GASKET               | 2             |
| 8  | 6 KÖŞE CİVATA M12x35               | SCREW M12x35                                      | 14            | 26 | BYPASS                  | PRESSURE RELIEF VALVE       | 1             |
| 9  | ARA FLANŞ                          | MOUNTING FLANGE                                   | 1             | 27 | 6 KÖŞE CİVATA<br>M8x25  | SCREW M8x25                 | 8             |
| 10 | KEÇE ø70xø110x13                   | LIP SEAL ø70xø110x13                              | 1             | 28 | BYPASS O-RING           | BYPASS O-RING               | 1             |
| 11 | MİL                                | SHAFT   | 1             | 29 | KLEPE                   | VALVE                       | 1             |
| 12 | ÇEVRE DİŞLİ KAMA<br>10x8x35 A      | ROTOR KEY 10x8x35 A                               | 1             | 30 | YAY                     | SPRING                      | 1             |
| 13 | GÖVDE CONTASI                      | CASING GASKET                                     | 1             | 31 | PUL                     | WASHER                      | 1             |
| 14 | ARA GÖVDE (BORU DİŞLİ<br>90°)      | CASING (w/ 90° THREADED<br>PORTS)                 | 1             | 32 | BYPASS KAPAĞI           | BYPASS COVER                | 1             |
| 15 | ARA GÖVDE (FLANŞLI<br>90°)         | CASING (w/ 90° FLANGED<br>PORTS)                  | 1             | 33 | TIJ KAPAK O-RİNG        | CAP O-RING                  | 1             |
| 16 | ARA GÖVDE (FLANŞLI<br>CEKETLİ 90°) | CASING (90° FLANGED PORTS<br>& w/ HEATING JACKET) | 1             | 34 | 6 KÖŞE CİVATA<br>M12x80 | ADJUSTING SCREW<br>M12x80   | 1             |
| 17 | ARA GÖVDE (FLANŞLI<br>180°)        | CASING (w/ 180° FLANGED<br>PORTS)                 | 1             | 35 | TIJ KAPAĞI              | CAP                         | 1             |
| 18 | KAPAK CONTASI                      | COVER GASKET                                      | 1             |    |                         |                             |               |

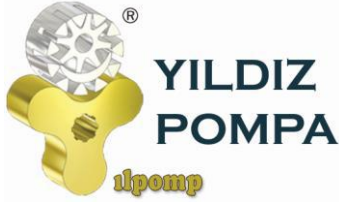

## YMBUF2½" POMPA INTERNAL ECCENTRIC GEAR PUMP



### YEDEK PARÇA LİSTESİ / SPARE PARTS LIST KEÇELİ, CEKETLİ VE KÖR KAPAKLI / SEALED WITH LIP SEAL, JACKETED AND WITH BLIND COVER

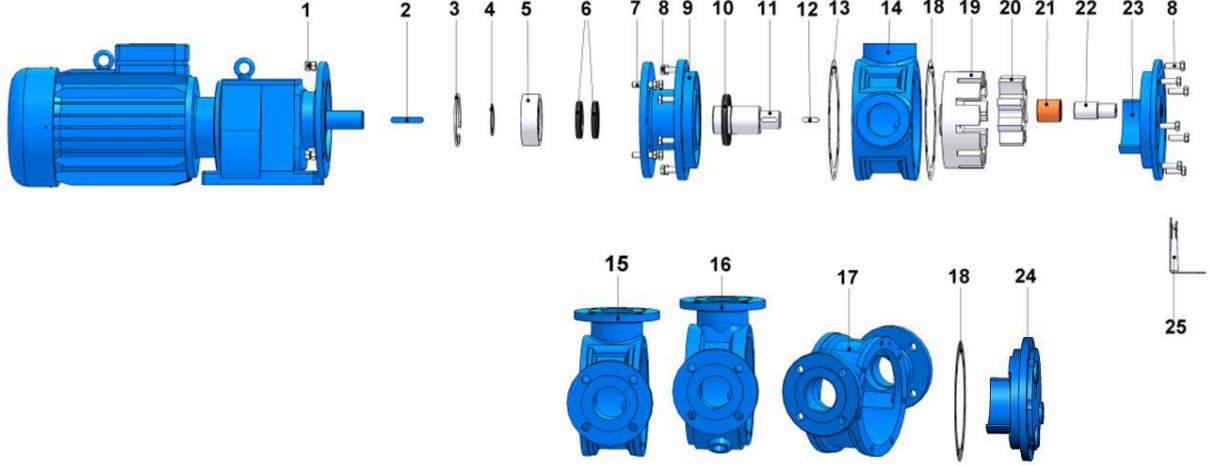

| No | PARÇA İSMİ                                 | PART NAME  | ADET/<br>QTY. | No | PARÇA İSMİ                         | PART NAME                                  | ADET/<br>QTY. |
|----|--|--|---------------|----|------------------------------------|--|---------------|
| 1  | M12 SOMUN                                  | NUT M12  | 4             | 14 | ARA GÖVDE (BORU<br>DİŞLİ 90°)      | CASING (w/ 90°<br>THREADED PORTS)          | 1             |
| 2  | KAMA 12x8x70 A                             | GEARMOTOR KEY<br>12x8x70 A                       | 1             | 15 | ARA GÖVDE (FLANŞLI<br>90°)         | CASING (w/ 90°<br>FLANGED PORTS)           | 1             |
| 3  | İÇ SEGMAN (ø110 )                          | INTERNAL CIRCLIP (ø110<br>)                      | 1             | 16 | ARA GÖVDE (FLANŞLI<br>CEKETLİ 90°) | CASING (90° FLANGED<br>w/ HEATING JACKETS) | 1             |
| 4  | DIŞ SEGMAN (ø60 )                          | EXTERNAL CIRCLIP (ø60 )                          | 1             | 17 | ARA GÖVDE (FLANŞLI<br>180°)        | CASING (w/ 180°<br>FLANGED PORTS)          | 1             |
| 5  | RULMAN (3212-2RS)                          | BALL BEARING (3212-<br>2RS)                      | 1             | 18 | KAPAK CONTASI                      | COVER GASKET                               | 2             |
| 6  | KEÇE ø60xø80x10                            | LIP SEAL ø60xø80x10                              | 2             | 19 | ÇEVRE DİŞLİ                        | ROTOR GEAR                                 | 1             |
| 7  | 6 KÖŞE CİVATA M12x45                       | SCREW M12x45                                     | 4             | 20 | AVARA DİŞLİ                        | IDLER GEAR                                 | 1             |
| 8  | 6 KÖŞE CİVATA M12x35                       | SCREW M12x35<br>FOR BLIND COVER                  | 15            | 21 | AVARA DİŞLİ BURCU                  | IDLER BUSHING                              | 1             |
|    | 6 KÖŞE CİVATA M12x40<br>CEKETLİ KAPAK İÇİN | SCREW M12x40<br>FOR COVER<br>(w/ HEATING JACKET) | 7             |    |                                    |  |               |
| 9  | ARA FLANŞ                                  | MOUNTING FLANGE                                  | 1             | 22 | KAPAK MİLİ                         | COVER PIN                                  | 1             |
| 10 | KEÇE ø70xø110x13                           | LIP SEAL ø70xø110x13                             | 1             | 23 | KAPAK (KÖR)                        | BLIND COVER                                | 1             |
| 11 | MİL  | SHAFT  | 1             | 24 | KAPAK (CEKETLİ)                    | COVER (w/ HEATING<br>JACKET)               | 1             |
| 12 | KAMA 10x8x35 A                             | ROTOR KEY 10x8x35 A                              | 1             | 25 | POMPA AYAK                         | PUMP SUPPORT                               | 1             |
| 13 | GÖVDE CONTASI                              | CASING GASKET                                    | 1             |    |                                    |  |               |