



YKF 5" POMPA INTERNAL ECCENTRIC GEAR PUMP



POMPA DEĞERLERİ / PUMP PROPERTIES

Q	: 170 m ³ /h
Hm	:1 ~ 9 Bar
T	:0 ~ 200 °C
n	:450 d/d
Visc.	:100 ~ 250.000 SSU

KULLANIM ALANLARI

- Fuel Oil Servis Tankları, Gaz Yağı, Mazot Tankerlerinde
- Reçine ve Polimerler
- Asfalt ve Bitüm
- Kağıt ve Boya Sanayinde
- Küçük çapta kızgın yağ sirkülasyonlarında
- İlaç, kimya ve deterjan sanayinde
- Gıda Sanayinde.

USE AREAS

- Fuel Oil Service Tanks, Gasoil, Diesel Tankers
- Resin and Polymer
- Asphalt and Bitumen
- Paper and Paint/dye industry
- Circulation of Hot Oil (limited)
- Medicine, Chemical and Detergent Industry
- Food Industry.

MALZEME SEÇENEKLERİ

- Pompa Gövdesi, Kapaklar : Dökme (pik) demir, Sfero döküm, Çelik döküm, Paslanmaz AISI 304- AISI 316 döküm
- Dişliler : Sfero döküm, Çelik döküm, Paslanmaz AISI 304- AISI 316 döküm
- Yataklar : Snbz 12 bronz, karbon grafit, Silisyum Karbür, Sert Metal Kaplama, rulman
- Sızdırmazlık: Yumuşak Salmastra, Rotatherm Salmastra, Mekanik salmastra. Keçeli Sistem, Kartex Mekanik Salmastra

MATERIAL OPTIONS

- Pump Body, covers : Pig Cast Iron, Spheroidal Cast iron, Cast Steel, AISI 304/316 CrNi Stainless Steel
- Gears : Spheroidal Cast iron, Cast Steel, AISI 304/316 CrNi Stainless Steel
- Bearings: Snbz 12 bronze, carbon graphite, silicon carbide, hard metal coated steel, bearing
- Sealing: Soft Seal or Packing Gland, Rotatherm Seal, Lip Seal, Mechanical Seal, Cartridge Type Mechanical Seal

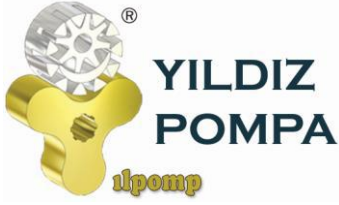

YKF 5" POMPA INTERNAL ECCENTRIC GEAR PUMP



İÇTEN EKSANTİK DİŞLİ POMPA ÇALIŞMA PRENSİBİ / WORKING PRINCIPLE OF INTERNAL ECCENTRIC GEAR PUMP

Yıldız Pompa' nın "dişli içinde dişli" prensibinde sadece iki tane hareketli parça vardır. Bütün pozitif deplasmanlı YILDIZ dişli pompalarının güvenilir ve verimli çalışmasının sırrı budur. Sıvının pozitif deplasmanı (yer değiştirmesi) rotor ve avare dişlisinin dişleri arasındaki boşluğun komple dolmasıyla sağlanmaktadır. Bütün dişli pompalarda olduğu gibi, YILDIZ POMPA' da da performansın en üst noktaya çıkmasını sınırlayıcı yegane faktör, pompalanan sıvının diğerlerine göre daha temiz olmasını istemesidir.

Pompa milinin her devrinde emiş ağızı yoluyla belli bir miktar sıvı pompaya girer. Bu sıvı rotor ile avare dişlisi arasındaki boşluğu doldurur. Pompa kapağında bulunan hilal, çıkış ağızına doğru pürüzsüz şekilde hareket eden sıvının akışını ayırır. Kendi dişleri ile hilalin iç yüzeyi arasında sıvı taşıyan avare dişlisi pompa kapağının desteklediği bir mil üzerinde döner. Dişleri arasında sıvı taşıyan rotor dişlisi pompa gövdesi ile hilalin dış yüzeyi arasında hareket eder ve pompa miline bağlıdır.

YILDIZ's simple "gear-within a gear" principle has only two moving parts. It is the secret of dependable, efficient operation of all positive displacement YILDIZ POMPA's PUMPS. The positive displacement of liquid is accomplished by the complete filling of the spaces between the teeth of the rotor and idler gears. The only limiting factor to peak performance in YILDIZ POMPA, as with all rotary pumps, is that the liquid pumped must be comparatively clean.

With every revolution of the pump's shaft, a definite amount of liquid enters the pump through the suction port. This liquid fills the spaces between the teeth of the rotor and the idler. The crescent on the pump head splits the flow of liquid as it moves smoothly towards the discharge port. The idler gear, which carries the liquid between its teeth and the inside surface of the crescent is connected to pump cover. On the otherhand, rotor gear which is rotated directly with pump shaft delivers the liquid between gear teeth and crescent's souter surface.

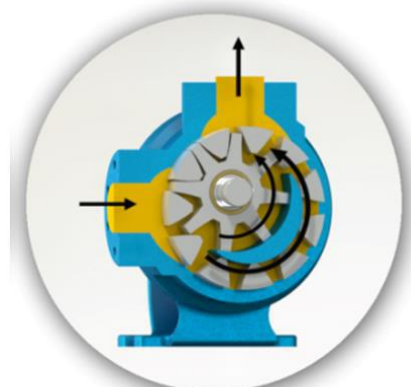
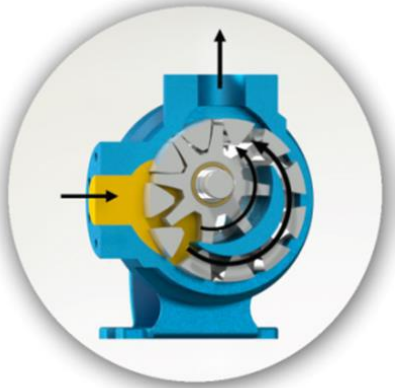

YKF 5" POMPA INTERNAL ECCENTRIC GEAR PUMP

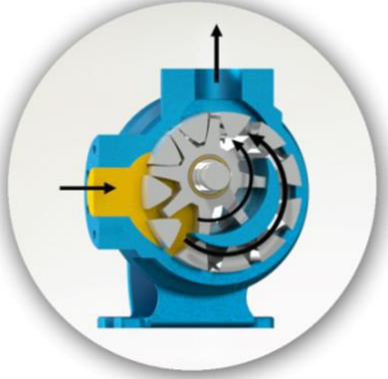

Yandaki renkli kısım sıvının pompa gövdesindeki emiş ağızı alanına, rotor dişlisi ve avare dişlisi dişleri arasındaki dişli boşlukları alanına girişini gösterir. İki siyah ok pompanın dönüş ve sıvının ilerleyişini gösterir.

The yellow colored portion at side indicates the liquid as it enters the suction port area of the casing and the area between the rotor teeth and corresponding concave area between the idler teeth. The two black arrows indicate the pump rotation and progress of the liquid.



"Dişli içinde dişli" prensibinde çalışan dişliler ile pompa içinde sıvının ilerleyişine dikkat edin. Aynı zamanda, pompa kapağı üzerindeki hilal şeklinin sıvıyı nasıl böldüğüne ve emiş ile boşaltma ağızları arasında bir keçe (conta) gibi vazife gördüğüne dikkat ediniz.

Notice the progress of the liquid through the pump and between the teeth of rotor idler gear. Also, note how the crescent shape on the head divides the liquid and acts as a seal between the suction and discharge ports.



Bu resim pompanın iç kısmının dolup sıvının boşaltma ağızı alanına itilmesinden hemen önceki durumunu göstermektedir. Avare ve rotor dişlilerinin dizaynının sıvı için nasıl bir kapalı cep oluşturduğuna ve bunun tam bir hacim kontrolü sağlanmasını nasıl garantilediğine dikkat ediniz.

This illustration shows the pump in a nearly flooded condition just previous to the liquid being forced into the discharge port area. Notice how the gear design of the idler and rotor form locked pockets for the liquid to guarantee absolute volume control.

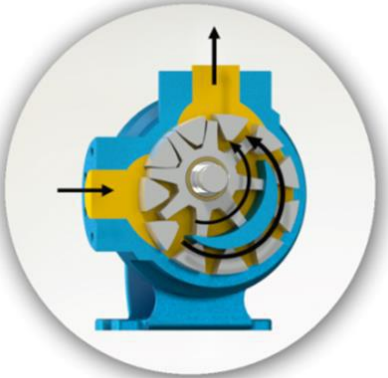

Bu görüntü pompanın tamamen dolup taşıdığı durumu ve sıvının boşaltma işlemini, boşaltma ağızından ilerleyişini göstermektedir. Emiş ve boşaltma ağızlarına eşit mesafede sızdırmaz bir keçe oluşturan, sıvıyı boşaltma ağızından dışarı doğru iten, rotor ve avare dişlisinin dişleri birbiri içine geçer.

The view shows the pump in a completely flooded condition and in the process of discharging the liquid through discharge port. The rotor and idler teeth mesh, forming a seal equidistant between the both ports, forcing liquid out the discharge port.



**YKF 5" POMPA
INTERNAL ECCENTRIC
GEAR PUMP**



YKF-5" POMPASINA AİT KAPASİTE VE GÜÇ TABLOSU / CAPACITY AND POWER TABLE						
KAPASİTE (m ³ /h) CAPACITY (Q)	DEVİR (d/d) SPEED (rpm)	ÇIKIŞ BASINCI / PRESSURE				VİSKOZİTE VISCOSITY
		3 Bar	5 Bar	7 Bar	9 Bar	
68	175	30 HP	40 HP	40 HP	50 HP	25.000 SSU
90	225	30 HP	40 HP	40 HP	50 HP	7.500 SSU
105	275	30 HP	40 HP	50 HP	60 HP	2.500 SSU
135	350	30 HP	40 HP	50 HP	60 HP	750 SSU

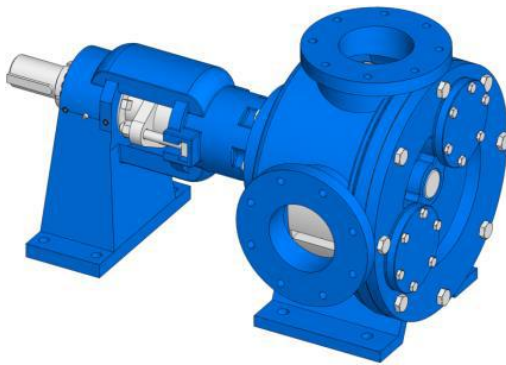
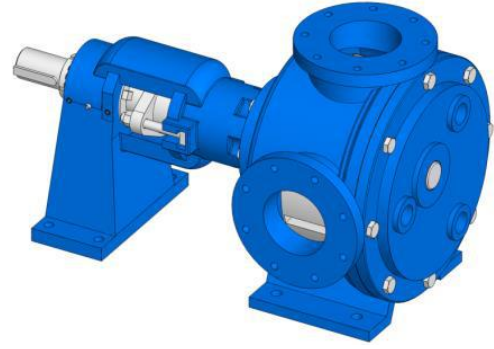



KAPASİTE EĞRİLERİ / CAPACITY GRAPHS

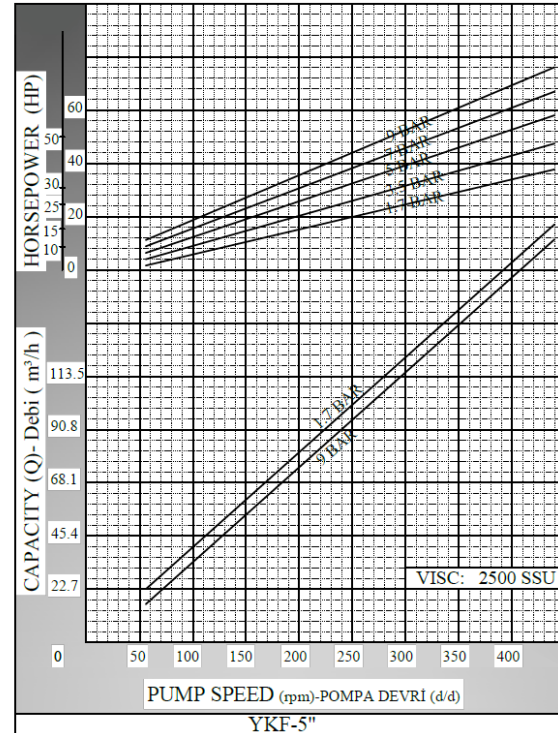
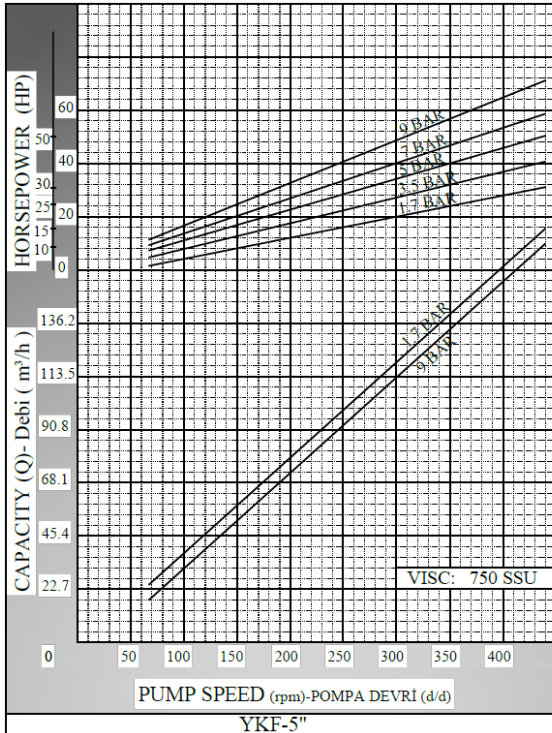
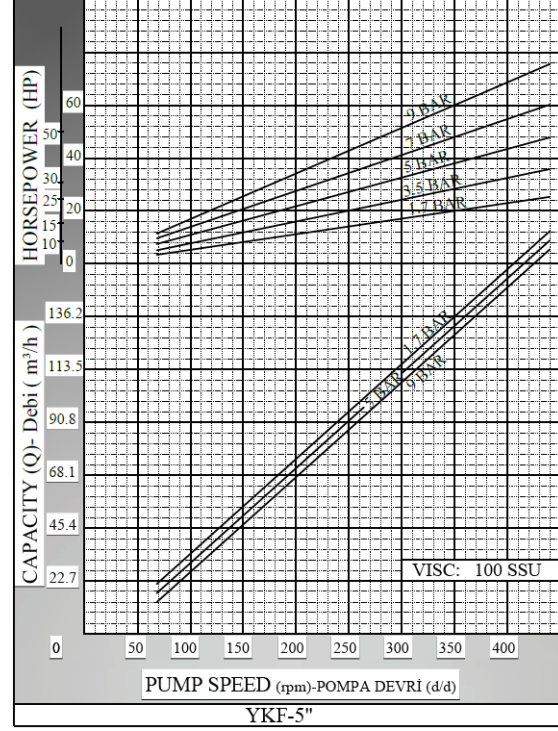
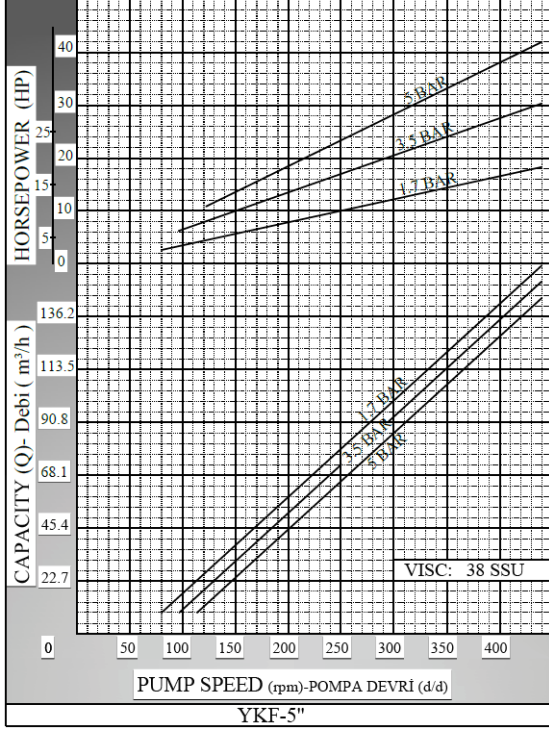



**YILDIZ
POMPA**

ilpomp

**YKF 5" POMPA
INTERNAL ECCENTRIC
GEAR PUMP**

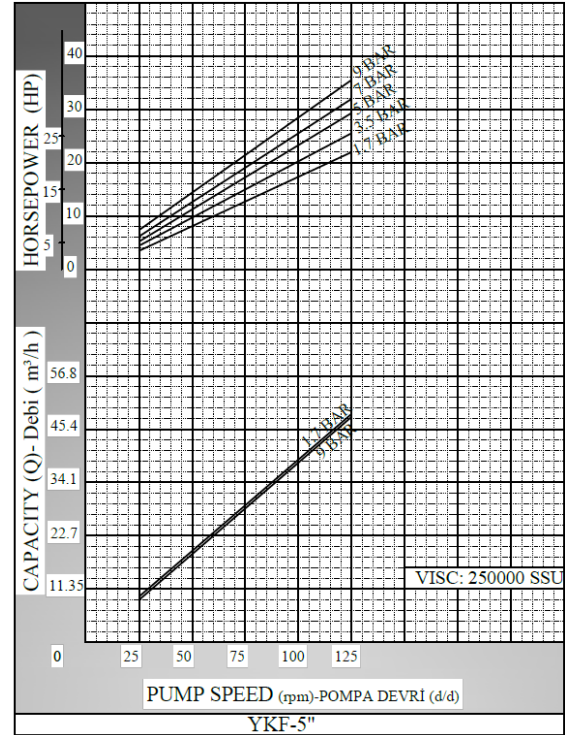
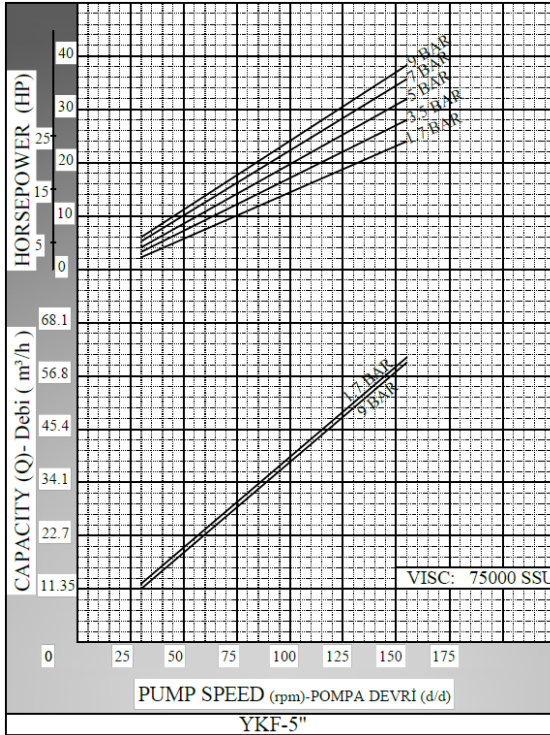
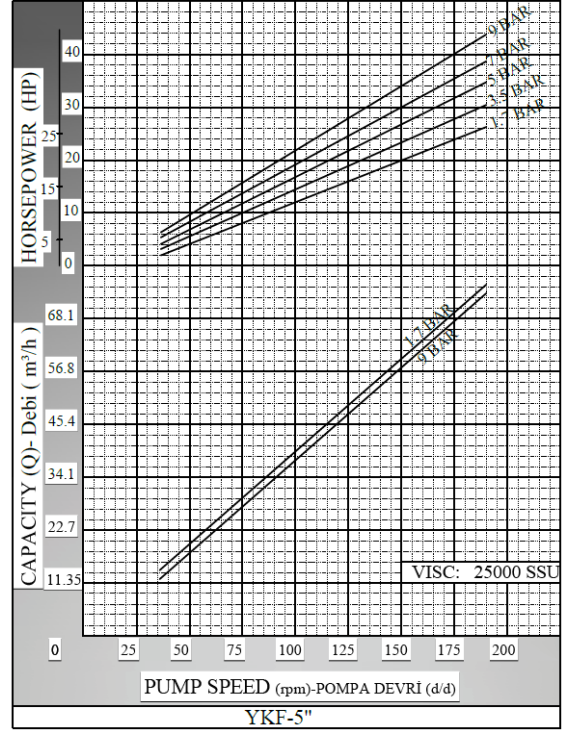
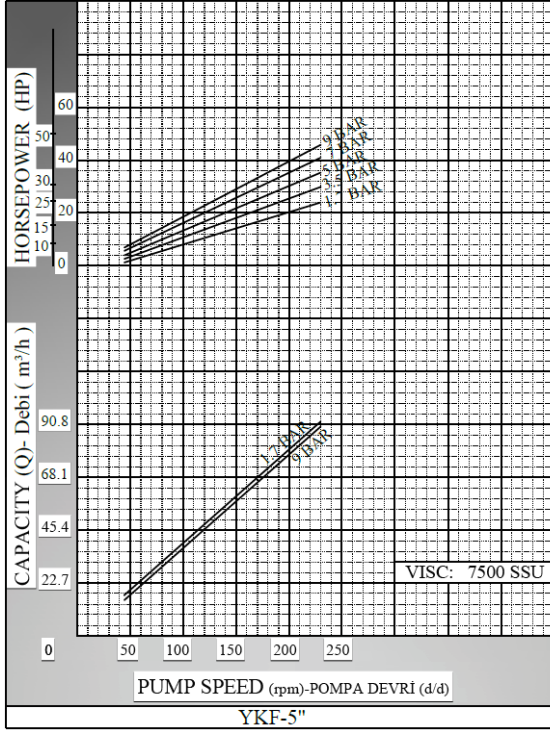

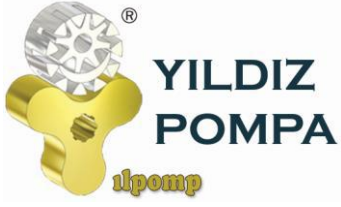

**YKF 5" POMPA
INTERNAL ECCENTRIC
GEAR PUMP**



POMPA BOYUT ÖLÇÜLERİ / PUMP DIMENSIONS

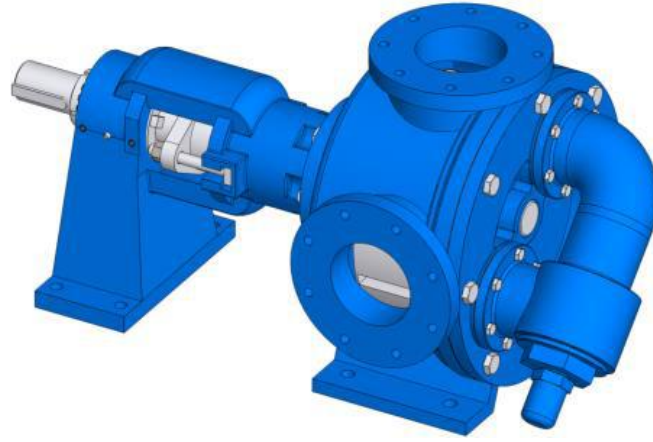
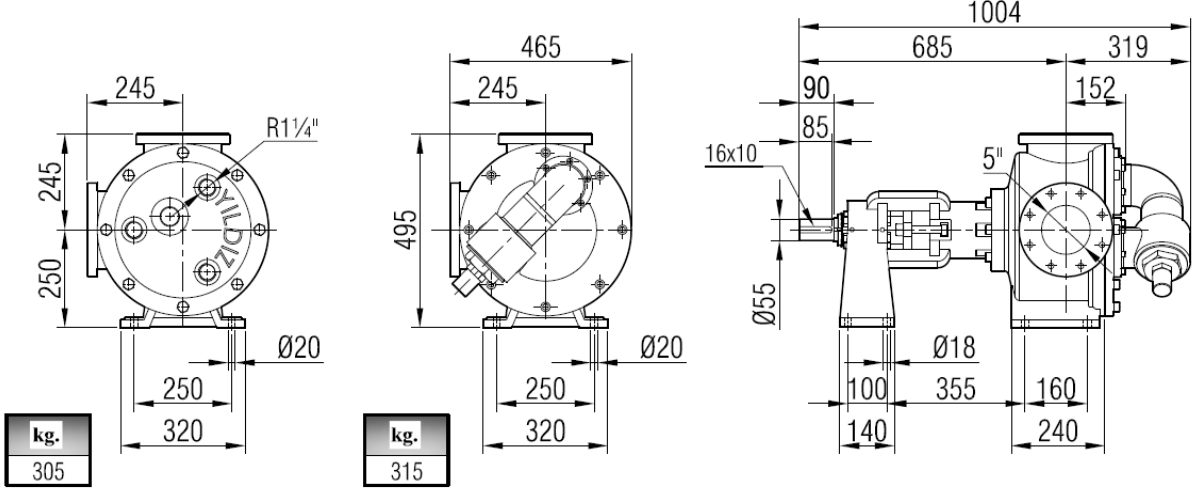



YKF 5" POMPA INTERNAL ECCENTRIC GEAR PUMP



AKUPLAJ ÖLÇÜLERİ / COUPLING DIMENSIONS REDÜKTÖR AKUPELİ / GEARBOX DRIVE

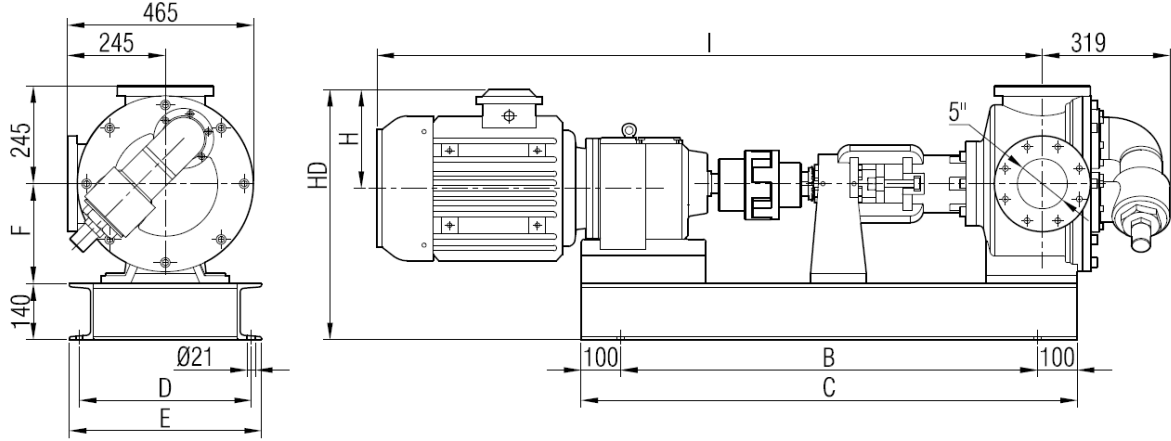

MOTOR GÜÇ VE DEVİRLERİ / MOTOR POWER AND SPEED			I	HD	H	B	C	D	E	F	kg.
25 hp / 18,5 kw	145/350 d/d (rpm)	İRAM82/180M	1665	626	248	1040	1240	430	480	250	667
30 hp / 22 kw	105/350 d/d (rpm)	İRAM92/180L	1783	617	275	1110	1310				712
40 hp / 30 kw	204/350 d/d (rpm)	İRAM92/200L	1822	644	275	1200	1400	520	570	872	
50 hp / 37 kw	89/350 d/d (rpm)	İRAM102/225S	1913	654	285	1200	1400	520	570	250	872
60 hp / 45 kw	113/350 d/d (rpm)	İRAM102/225M	1942								935

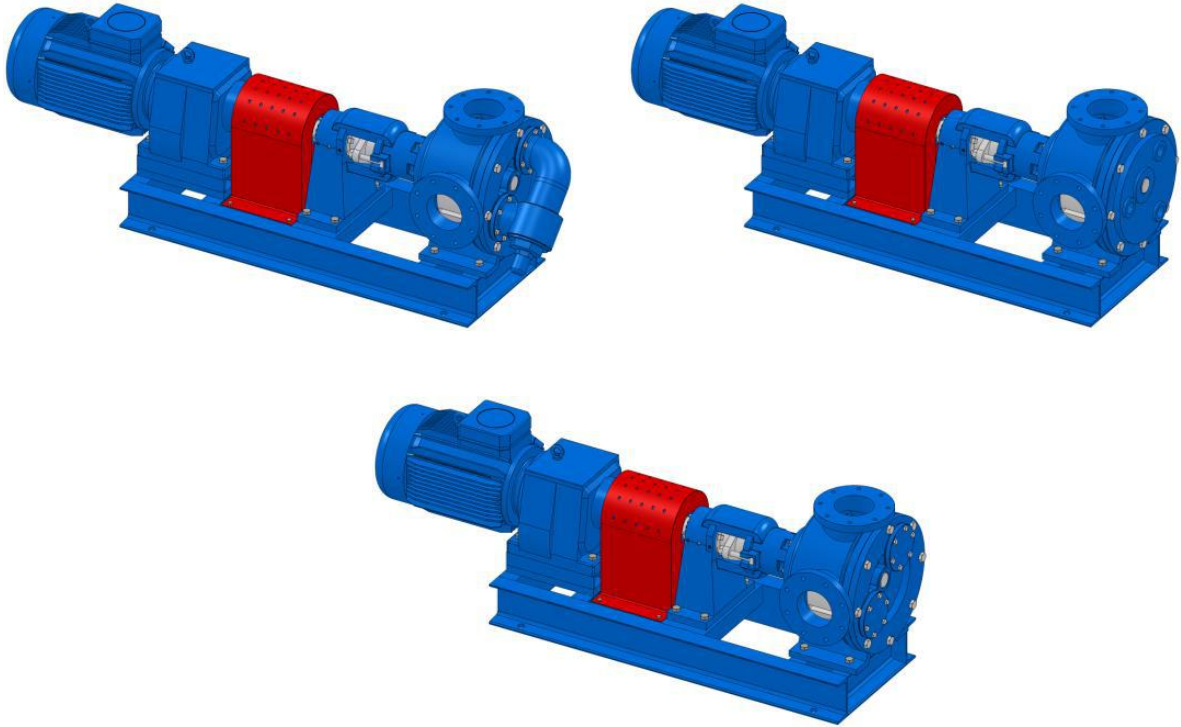



YKF 5" POMPA INTERNAL ECCENTRIC GEAR PUMP



YEDEK PARÇA LİSTESİ / SPARE PARTS LIST

YUMUŞAK SALMASTRALI VE BYPASSLI / SEALED WITH SOFT SEAL AND PRESSURE RELIEF VALVE ON COVER

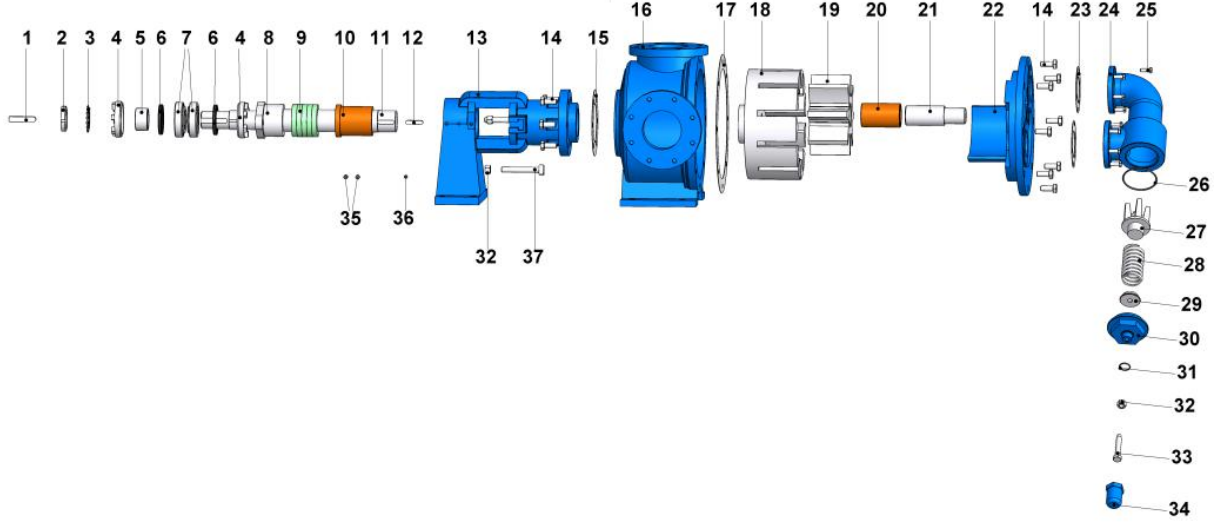

No	PARÇA İSMİ	PART NAME	ADET/ QTY.	No	PARÇA İSMİ	PART NAME	ADET/ QTY.
1	KAMA 16x10x85 AB	COUPLING KEY 16x10x85 AB	1	20	AVARA DİŞLİ BURCU	IDLER BUSHING	1
2	KİLİT SOMUNU	LOCK NUT	1	21	KAPAK MİLİ	COVER PIN	1
3	KİLİT SACI	LOCK WASHER	1	22	KAPAK (KÖR ve BYPASSLI)	COVER	1
4	AYAR SOMUNU	ADJUSTING NUT	2	23	BYPASS CONTASI	BYPASS GASKET	2
5	BİLEZİK (AYAR SOMUNLU)	SPACER (ADJUSTING NUT)	1	24	BYPASS	PRESSURE RELIEF VALVE BYPASS	1
6	KEÇE $\phi 70 \times \phi 95 \times 10$	LIP SEAL $\phi 70 \times \phi 95 \times 10$	2	25	6 KÖŞE CİVATA M10x30	HEX BOLT M10x30	12
7	RULMAN (32212)	BALL BEARING (32212)	2	26	BYPASS O-RING	BYPASS O-RING	1
8	SALMASTRA BASKISI	PACKING PRESS	1	27	KLEPE	VALVE	1
9	YUMUŞAK SALMASTRA	SOFT SEAL / PACKING GLAND	1 TK.	28	YAY	SPRING	1
10	KONSOL BURCU	BRACKET BUSHING	1	29	PUL	WASHER	1
11	MİL	SHAFT	1	30	BYPASS KAPAĞI	BYPASS COVER	1
12	KAMA 12x8x55 A	ROTOR KEY 12x8x55 A	1	31	TİJ KAPAK O-RİNG	CAP O-RING	1
13	KONSOL	BRACKET	1	32	M16 SOMUN	NUT M16	3
14	6 KÖŞE CİVATA M16x40	HEX BOLT M16x40	14	33	6 KÖŞE CİVATA M16x90	ADJUSTING SCREW M16x90	1
15	KONSOL CONTASI	BRACKET GASKET	1	34	TİJ KAPAĞI	CAP	1
16	ARA GÖVDE (FLANŞLI 90°)	CASING (w/ 90° FLANGED PORTS)	1	35	SETUSKUR M12x20	GRUB SCREW M12x20	4
17	KAPAK CONTASI	BRACKET GASKET	1	36	GRESÖR R3/8"	GREASING FITTING R3/8"	1
18	ÇEVRE DİŞLİ	ROTOR GEAR	1	37	4 KÖŞE SALMASTRA BASKI CİVATASI M16x120	SQUARE SCREW M16x120	2
19	AVARA DİŞLİ	IDLER GEAR	1				



YKF 5" POMPA INTERNAL ECCENTRIC GEAR PUMP



YEDEK PARÇA LİSTESİ / SPARE PARTS LIST

YUMUŞAK SALMASTRALI, CEKETLİ VE KÖR KAPAKLI / SEALED WITH SOFT SEAL, JACKETED,
AND WITH BLIND COVER

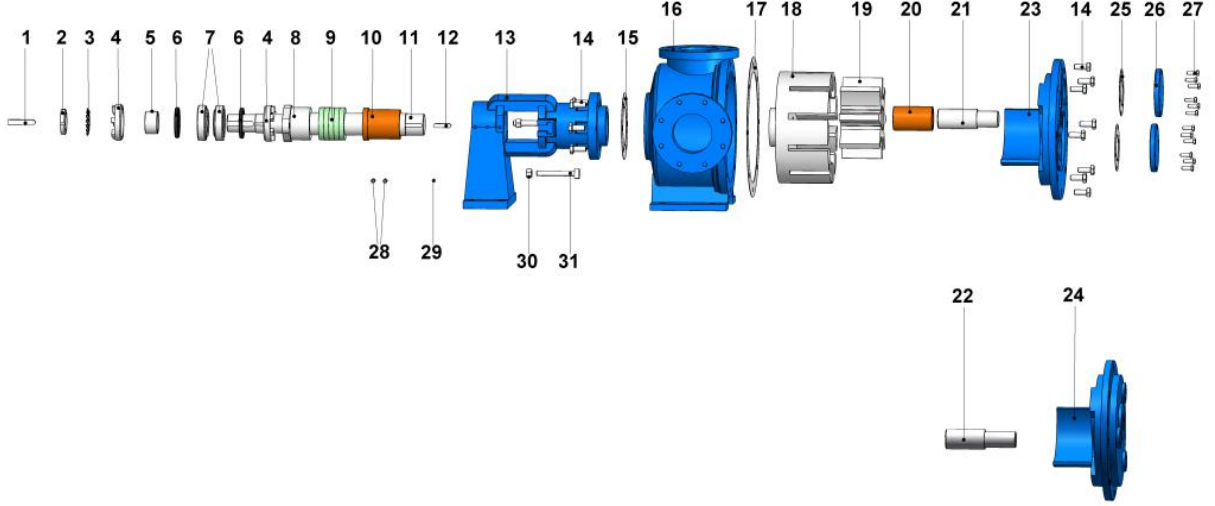

No	PARÇA İSMİ	PART NAME	ADET/ QTY.	No	PARÇA İSMİ	PART NAME	ADET/ QTY.
1	KAMA 16x10x85 AB	COUPLING KEY 16x10x85 AB	1	17	KAPAK CONTASI	BRACKET GASKET	1
2	KİLİT SOMUNU	LOCK NUT	1	18	ÇEVRE DİŞLİ	ROTOR GEAR	1
3	KİLİT SACI	LOCK WASHER	1	19	AVARA DİŞLİ	IDLER GEAR	1
4	AYAR SOMUNU	ADJUSTING NUT	2	20	AVARA DİŞLİ BURCU	IDLER BUSHING	1
5	BİLEZİK (AYAR SOMUNLU)	SPACER (ADJUSTING NUT)	1	21	KAPAK MİLİ	COVER PIN	1
6	KEÇE $\phi 70 \times \phi 95 \times 10$	LIP SEAL $\phi 70 \times \phi 95 \times 10$	2	22	CEKETLİ KAPAK MİLİ	JACKETED COVER PIN	1
7	RULMAN (32212)	BALL BEARING (32212)	2	23	KAPAK (KÖR ve BYPASSLI)	COVER	1
8	SALMASTRA BASKISI	PACKING PRESS	1	24	KAPAK (CEKETLİ)	JACKETED COVER	1
9	YUMUŞAK SALMASTRA	SOFT SEAL / PACKING GLAND	1 TK.	25	BYPASS CONTASI	BYPASS GASKET	2
10	KONSOL BURCU	BRACKET BUSHING	1	26	BYPASS KÖR KAPAK	PRESSURE RELIEF VALVE - BYPASS	2
11	MİL	SHAFT	1	27	6 KÖŞE CİVATA M10x30	HEX BOLT M10x30	12
12	KAMA 12x8x55 A	ROTOR KEY 12x8x55 A	1	28	SETUSKUR M12x20	GRUB SCREW M12x20	4
13	KONSOL	BRACKET	1	29	GRESÖR R3/8"	GREASING FITTING R3/8"	1
14	6 KÖŞE CİVATA M16x40	HEX BOLT M16x40	14	30	M16 SOMUN	NUT M16	2
15	KONSOL CONTASI	BRACKET GASKET	1	31	4 KÖŞE SALMASTRA BASKI CİVATASI M16x120	SQUARE SCREW M16x120	2
16	ARA GÖVDE (FLANŞLI 90°)	CASING (w/ 90° FLANGED PORTS)	1				



YKF 5" POMPA INTERNAL ECCENTRIC GEAR PUMP



YEDEK PARÇA LİSTESİ / SPARE PARTS LIST

MEKANİK SALMASTRALI VE BYPASSLI / SEALED WITH MECHANICAL SEAL, AND PRESSURE RELIEF VALVE ON COVER

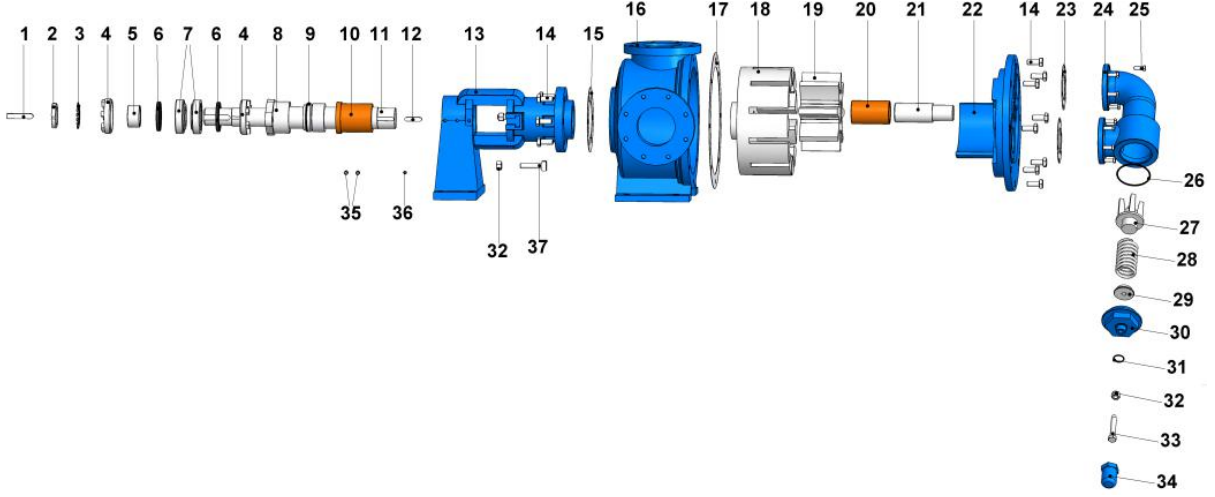

No	PARÇA İSMİ	PART NAME	ADET/ QTY.	No	PARÇA İSMİ	PART NAME	ADET/ QTY.
1	KAMA 16x10x85 AB	COUPLING KEY 16x10x85 AB	1	20	AVARA DİŞLİ BURCU	IDLER BUSHING	1
2	KİLİT SOMUNU	LOCK NUT	1	21	KAPAK MİLİ	COVER PIN	1
3	KİLİT SACI	LOCK WASHER	1	22	KAPAK (KÖR ve BYPASSLI)	COVER	1
4	AYAR SOMUNU	ADJUSTING NUT	2	23	BYPASS CONTASI	BYPASS GASKET	2
5	BİLEZİK (AYAR SOMUNLU)	SPACER (ADJUSTING NUT)	1	24	BYPASS	PRESSURE RELIEF VALVE - BYPASS	1
6	KEÇE Ø70xØ95x10	LIP SEAL Ø70xØ95x10	2	25	6 KÖŞE CİVATA M10x30	HEX BOLT M10x30	12
7	RULMAN (32212)	BALL BEARING (32212)	2	26	BYPASS O-RING	BYPASS O-RING	1
8	SALMASTRA BASKISI(MEKANİKLİ İÇİN)	PACKING PRESS (FOR MECHANICAL SEAL)	1	27	KLEPE	VALVE	1
9	MEKANİK SALMASTRA Ø70	MECHANICAL SEAL Ø70	1	28	YAY	SPRING	1
10	KONSOL BURCU	BRACKET BUSHING	1	29	PUL	WASHER	1
11	MİL	SHAFT	1	30	BYPASS KAPAĞI	BYPASS COVER	1
12	KAMA 12x8x55 A	ROTOR KEY 12x8x55 A	1	31	TIJ KAPAK O-RİNG	CAP O-RING	1
13	KONSOL	BRACKET	1	32	M16 SOMUN	NUT M16	3
14	6 KÖŞE CİVATA M16x40	HEX BOLT M16x40	14	33	6 KÖŞE CİVATA M16x90	ADJUSTING SCREW M16x90	1
15	KONSOL CONTASI	BRACKET GASKET	1	34	TIJ KAPAĞI	CAP	1
16	ARA GÖVDE (FLANŞLI 90°)	CASING (w/ 90° FLANGED PORTS)	1	35	SETUSKUR M12x20	GRUB SCREW M12x20	4
17	KAPAK CONTASI	BRACKET GASKET	1	36	GRESÖR R3/8"	GREASING FITTING R3/8"	1
18	ÇEVRE DİŞLİ	ROTOR GEAR	1	37	4 KÖŞE SALMASTRA BASKI CİVATASI M16x70	SQUARE SCREW M16x70	2
19	AVARA DİŞLİ	IDLER GEAR	1				



YKF 5" POMPA INTERNAL ECCENTRIC GEAR PUMP



YEDEK PARÇA LİSTESİ / SPARE PARTS LIST MEKANİK SALMASTRALI, CEKETLİ VE KÖR KAPAKLI / SEALED WITH MECHANICAL SEAL, JACKETED, AND WITH BLIND COVER

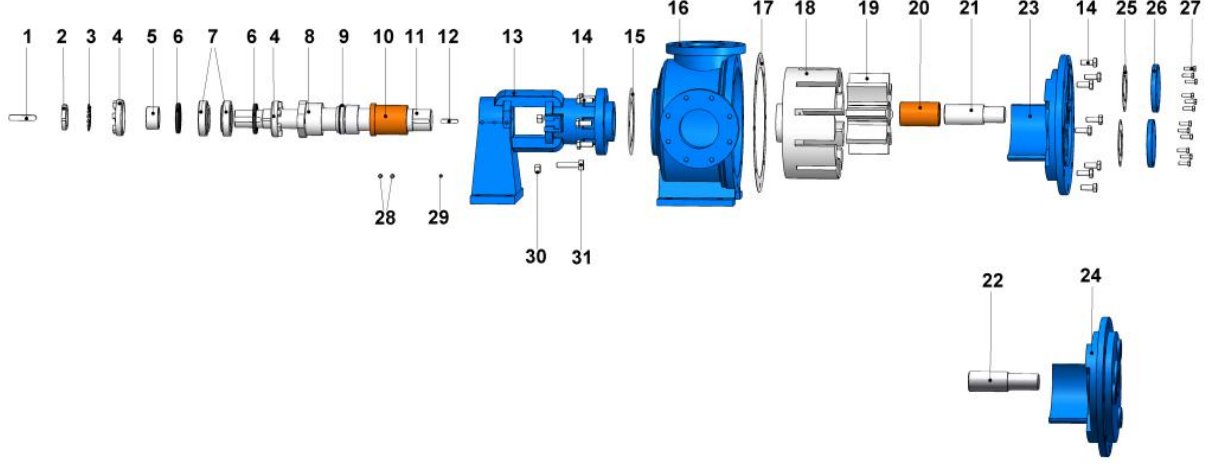

No	PARÇA İSMİ	PART NAME	ADET/ QTY.	No	PARÇA İSMİ	PART NAME	ADET/ QTY.
1	KAMA 16x10x85 AB	COUPLING KEY 16x10x85 AB	1	17	KAPAK CONTASI	BRACKET GASKET	1
2	KİLİT SOMUNU	LOCK NUT	1	18	ÇEVRE DİŞLİ	ROTOR GEAR	1
3	KİLİT SACI	LOCK WASHER	1	19	AVARA DİŞLİ	IDLER GEAR	1
4	AYAR SOMUNU	ADJUSTING NUT	2	20	AVARA DİŞLİ BURCU	IDLER BUSHING	1
5	BİLEZİK (AYAR SOMUNLU)	SPACER (ADJUSTING NUT)	1	21	KAPAK MİLİ	COVER PIN	1
6	KEÇE $\phi 70 \times \phi 95 \times 10$	LIP SEAL $\phi 70 \times \phi 95 \times 10$	2	22	CEKETLİ KAPAK MİLİ	JACKETED COVER PIN	1
7	RULMAN (32212)	BALL BEARING (32212)	2	23	KAPAK (KÖR ve BYPASSLI)	COVER	1
8	SALMASTRA BASKISI (MEKANİK İÇİN)	PACKING PRESS (FOR MECHANICAL SEAL)	1	24	KAPAK (CEKETLİ)	JACKETED COVER	1
9	MEKANİK SALMASTRA $\phi 70$	MECHANICAL SEAL $\phi 70$	1	25	BYPASS CONTASI	BYPASS GASKET	2
10	KONSOL BURCU	BRACKET BUSHING	1	26	BYPASS KÖR KAPAK	PRESSURE RELIEF VALVE - BYPASS	2
11	MİL	SHAFT	1	27	6 KÖŞE CİVATA M10x30	HEX BOLT M10x30	12
12	KAMA 12x8x55 A	ROTOR KEY 12x8x55 A	1	28	SETUSKUR M12x20	GRUB SCREW M12x20	4
13	KONSOL	BRACKET	1	29	GRESÖR R3/8"	GREASING FITTING R3/8"	1
14	6 KÖŞE CİVATA M16x40	HEX BOLT M16x40	14	30	M16 SOMUN	NUT M16	2
15	KONSOL CONTASI	BRACKET GASKET	1	31	4 KÖŞE SALMASTRA BASKI CİVATASI M16x70	SQUARE SCREW M16x70	2
16	ARA GÖVDE (FLANŞLI 90°)	CASING (w/ 90° FLANGED PORTS)	1				