

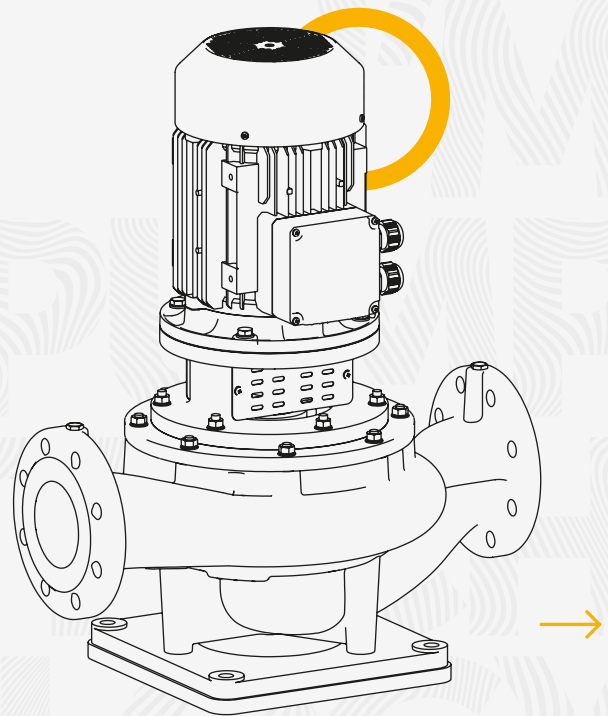

# TKF-1 Series

**In-Line Type Centrifugal Pump**

Hat Tipi (In-Line) Santrifüj Pompa



01.2023 - v1



[www.sempapompa.com](http://www.sempapompa.com)



power **traction** thrust



SEM  
PUMPA  
TECH  
NOLOGY



**GENEL MERKEZ - FABRİKA / CENTER - FACTORY**

BüyükkayacıkOSB Mh. 22. Sk. No:4 42250  
Selçuklu / KONYA / TÜRKİYE  
Tel: +90 332 345 32 90 | 444 64 13  
E-posta: info@sempapompa.com



**SEMPA PLAZA / SEMPA STORE**

Fevziçakmak Mh. 10644. Sk. No:43-45-47  
Karatay / KONYA / TÜRKİYE  
Tel: +90 332 237 03 31  
E-posta: info@sempamotor.com

## GENERAL INFORMATION

Discharge Flange	DN 40 - DN 200
Capacity	up to 650 m <sup>3</sup> /h
Head	up to 140 m
Working Temperature	From -25 °C to +140 °C*
Casign Pressure (Pmax)	10 bar (16 bar)*

(Pmax: Suction Pressure + Shut off Head)

(\*) Depending on the type of liquid, operating temperature and pressure. The pump material changes. Please contact our company for detailed information.

## Transferable Liquids

- Clean or slightly contaminated low viscosity liquids without solid & fibrous particles.

## Shaft Sealing

- Depending on customer request or liquid type, mechanical seals are available.

## Applications

Water Treatment and Pressurization
Heating Ventilating and Air Conditioning
Agricultural Irrigation and Drainage
Food and Beverage Industry
Marine
Building Systems

## Design Features

- Single-stage, closed impeller monoblock centrifugal pumps with volute, which can be connected to straight pipe (line type).
- Suction and discharge flanges conform to TS EN 1092-2 / PN 16. For pumps with steel or stainless steel housing, the flanges comply with TS EN 1092 - 1 / PN 16. It can be produced with ANSI / ASME flange upon request.
- Pumps are used with high efficiency electric motors according to IEC construction sizes.
- All impellers are balanced dynamically or statically in accordance with ISO 1940 class 6.3.
- Axial force is balanced with impeller balancing holes system.
- Optionally, pumps can be manufactured with wear ring and / or shaft bushing.
- The direction of rotation is clockwise when viewed from the motor side.
- The pump shaft is connected to the motor shaft by means of a shaft or rigid coupling and the axial and radial forces of the pump are compensated by the motor bearings.

## Pump Code

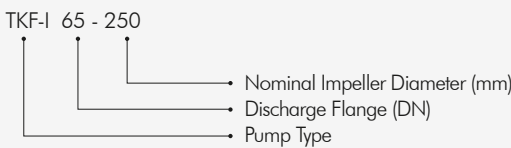

## GENEL BİLGİLER

Basma Flaşı	DN 40 - DN 200
Debi	650 m <sup>3</sup> /h 'ye kadar
Basma Yüksekliği	140 m 'ye kadar
Çalışma Sıcaklığı	-25 °C den +140 °C'ye kadar*
Gövde Basıncı (Pmaks)	10 bar (16 bar)*

(Pmaks: Emme Basıncı + Kapalı Vanadaki Basma Yüksekliği)

(\*) Basılan sıvının cinsine, çalışma sıcaklığı ve basıncına bağlı olarak pompa malzemesi değişir. Ayrıntılı bilgi için firmamıza başvurunuz.

## Basılabilen Sıvılar

- İçinde katı parçacıklar ve elyaf bulunmayan, temiz veya çok hafif kirli, düşük viskoziteli sıvılar.

## Mil Sızdırmazlığı

- Müşterinin isteğine veya sıvının cinsine göre mekanik salmastra kullanılmaktadır.

## Kullanım Yerleri

Su Artırımı ve Basınçlandırılması
Isıtma, Havalandırma ve İklimlendirme
Tarımsal Sulama ve Drenaj
Gıda ve İçecek Endüstrisi
Denizcilik
Bina Sistemleri

## Tasarım Özellikleri

- Düz boruya bağlanabilen (hat tipi), salyangozlu, tek kademeli, kapalı çarklı monoblok santrifüj pompalar.
- Emme ve basma flaşları TS EN 1092 - 2 / PN 16' ya uygundur. Çelik veya paslanmaz çelik gövde malzemeli pompalarda flaşlar TS EN 1092 - 1 / PN 16' ya uygundur. İsteğe bağlı olarak ANSI/ASME flaşlı olarak da üretim yapılabilmektedir.
- Pompalar IEC yapı büyüklüklerine uygun yüksek verimlilik sınıfında elektrik motorları ile kullanılır.
- Bütün çarklar ISO 1940 sınıf 6.3' e uygun dinamik veya statik olarak dengelenmektedir.
- Eksenel kuvvet çark dengeleme delikleri sistemi ile dengelenmiştir.
- İsteğe bağlı olarak pompalar aşınma halkalı ve/veya mil burçlu imal edilebilir.
- Dönme yönü motor tarafından bakılınca saat yönündedir.
- Pompa mili motor miline geçme mil veya rijit kaplin ile bağlanmıştır ve pompanın eksenel ve radyal kuvvetleri motor rulmanları tarafından karşılanmaktadır.

## Pompa Kodu

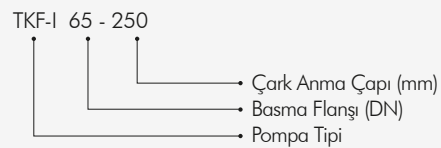

## MATERIAL OPTIONS

## MALZEME SEÇENEKLERİ

Part List	0.6025	0.7040	0.7043	1.0619	1.4308	1.4309	1.4408	1.4409	1.4500	1.4517	1.4469	1.4317	1.4008	2.1050	2.0975	2.1096	1.4021	1.4021	1.4301	1.4404	1.4460	1.4462	Parça Listesi
Volute	●	○	○	○	○	○	○	○	○	○	○	○	○	○									Salyangoz Gövde
Seal Box	●	○	○	○	○	○	○	○	○	○	○	○	○	○									Salmastra Yatağı
Impeller	●	○	○	○	○	○	○	○	○	○	○	○	○	○	○	○						○	Çark
Shaft																	●	○	○	○		○	Mil
Motor Carrier	●	○	○	○	○	○	○	○															Rulman Yatağı
Wear Ring	○	○	○	○	○	○	○	○	○	○	○	○	○	○	○	○							Aşınma Halkası
Mech. S. Setting Nut																	●	○	○	○		○	Mek. Sal. Ara Burcu
Lower Table	●	○																					Alt Tabla
Mech. Seal (*)	EN 12756 / DIN 24250																				Mek. Salmastra (*)		

Mechanical seal can be used in different types and brands depending on working conditions or customer request.

Alıcının isteğine veya çalışma şartlarına bağlı olarak, farklı tip ve markalarda mekanik salmastra kullanılabilir.

- Standard Manufacturing
- Optional

- Standart İmalat
- İsteğe Bağlı

## DESCRIPTIONS

🔧 DIN

🔧 EN

🔧 AISI / SAE / ASTM

## TANIM

	DIN	EN	AISI / SAE / ASTM	TANIM
Cast Iron	0.6025	EN-GJL-250 (GG25)	A 48 Class 40-B	Pik Döküm
Ductile Iron Casting	0.7040	EN-GJS-400 -15	A 536 60-40-18	Sfero Döküm
Ductile Iron Casting	0.7043	EN-GJS-400-18-LT (GGG40.3)	A 536 60-40-18	Sfero Döküm
Steel Casting	1.0619	GP240GHGS-C25	A 216 WCB	Çelik Döküm
Chrome Nickel Steel Casting	1.4308	GX5 Cr Ni 19-10	A 351 CF8	Krom Nikelli Çelik Döküm
Chrome Nickel Steel Casting (L.C.)	1.4309	G-X2 Cr Ni 19-11	A 351 CF3	Krom Nikel Çelik Döküm (D.K.)
Chrome Nickel Molybdenum Steel Casting	1.4408	G-X5Cr Ni Mo 19-11-2	A 351 CF8M	Krom Nikel Molibdenli Çelik Döküm
Chrome Nickel Molybdenum Steel Casting (L.C.)	1.4409	G-X2 Cr Ni Mo 19-11-2	A 351 CF3M	Krom Nikel Molibdenli Çelik Döküm (D.K.)
Austenitic Steel Casting	1.4500	G-X7 Ni Cr Mo Cu Nb 25-20	A 351 CN7M	Östenitik Çelik Döküm
Austenitic Ferritic Steel Casting (Duplex)	1.4517	G-X2 Cr Ni Mo Cu N 25-6-3-3	A 890 CD4MCuN	Östenitik-ferritik Çelik Döküm (Duplex)
Austenitic Ferritic Steel Casting (Super Duplex)	1.4469	G-X2 Cr Ni Mo N 26-7-4	A 890 CE3MN	Östenitik-ferritik Çelik Döküm (S.D.)
Martensitic Stainless Steel Casting	1.4317	G-X4 Cr Ni 13-4	A 352 CA6NM	Martenzitik Paslanmaz Çelik Döküm
Martensitic Stainless Steel Casting	1.4008	G-X7 Cr Ni Mo 12-1	A 217 CA15	Martenzitik Paslanmaz Çelik Döküm
Bronze Casting (Tinned)	2.1050.01	G-Cu Sn 10	B 427 C90700	Bronz Döküm (Kalaylı)
Bronze Casting (Nickel Alloy)	2.0975.01	G-Cu Al 10 Ni	B 148 C95500	Bronz Döküm (Nikel Alaşımli)
Bronze Casting (Leaded)	2.1096.01	G-Cu Sn 5Z Pb	B 584 C83600	Bronz Döküm (Kurşunlu)
Chromium Steel	1.4021	X20Cr13	A 276 Type 420	Kromlu Çelik
Chromium Steel (Heat Treatment)	1.4021	X20Cr13	A 276 Type 420+QT	Kromlu Çelik (Isıl İşlem)
Chrome Nickel Steel	1.4301	X5 Cr Ni Mo 18-10	A 276 Type 304	Krom Nikel Çelik
Chrome Nickel Molybdenum Steel (L.C.)	1.4404	X2 Cr Ni Mo N 17-12-2	A 276 Type 316L	Krom Nikel Molibdenli Çelik (D.K.)
Duplex (Austenitic Ferritic) Steel	1.4460	X3 Cr Ni Mo N 27-5-2	AISI 329	Dubleks (Östenitik-Ferritik) Çelik
Duplex (Austenitic Ferritic) Steel	1.4462	X2 Cr Ni Mo N 22-5-3	UNS S32205	Dubleks (Östenitik-Ferritik) Çelik



## 1450 rpm / (d/d) (50 Hz)

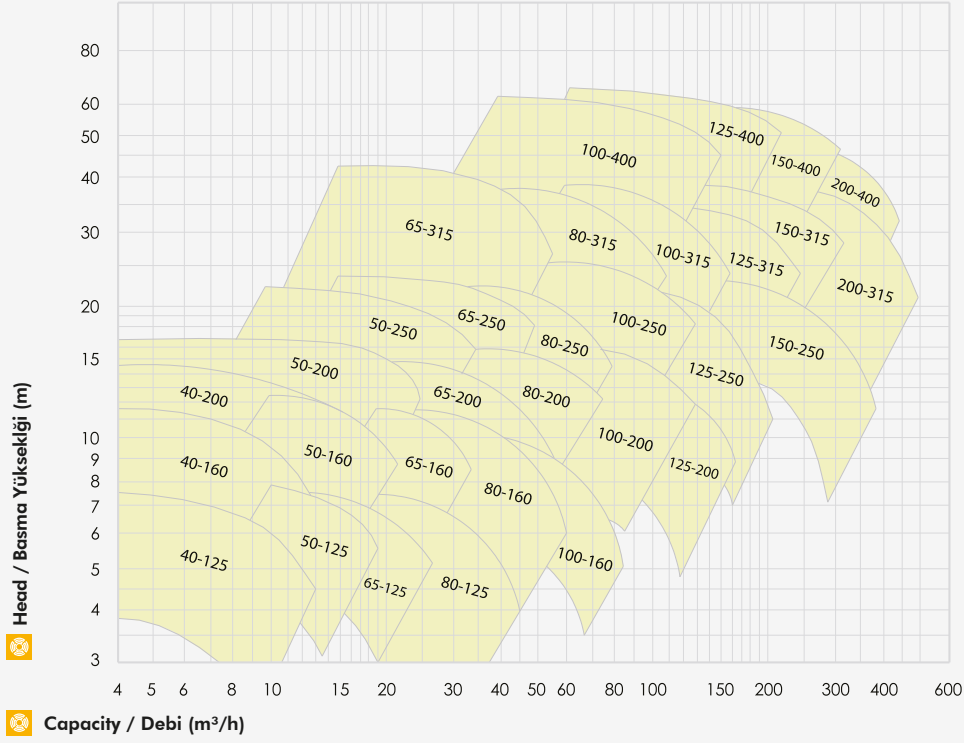

## 2900 rpm / (d/d) (50 Hz)

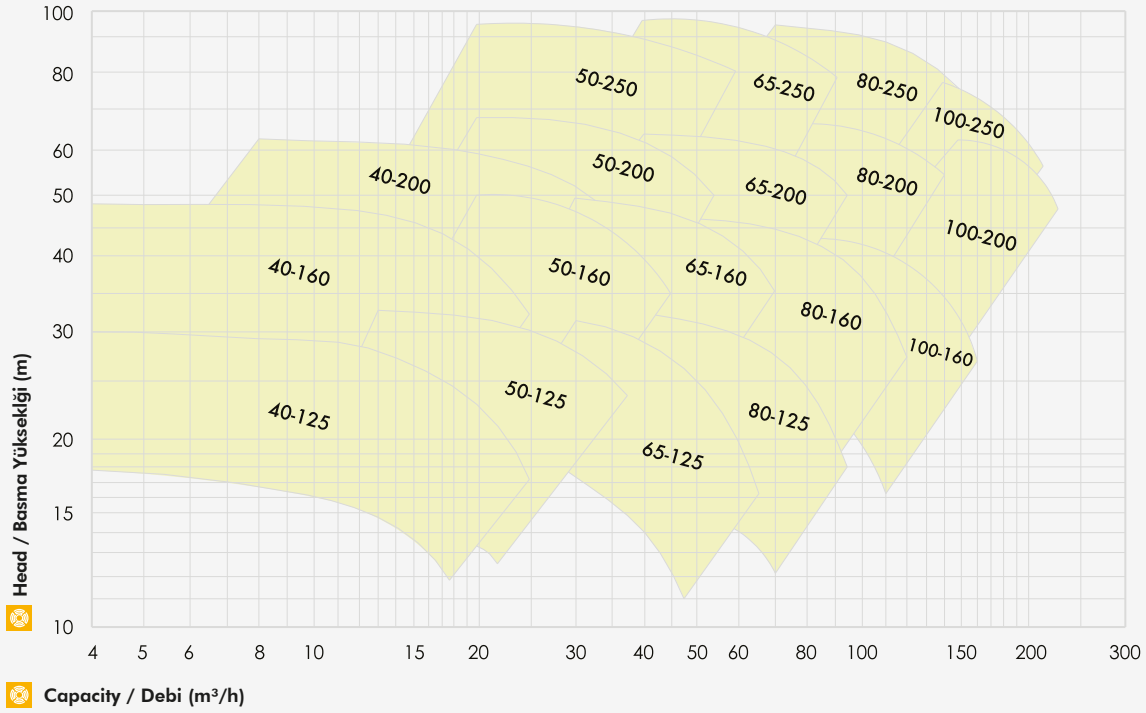

For detailed curves, use our selection program.

Detay eğriler için seçim programımızı kullanınız.



## 1750 rpm / (d/d) (60 Hz)

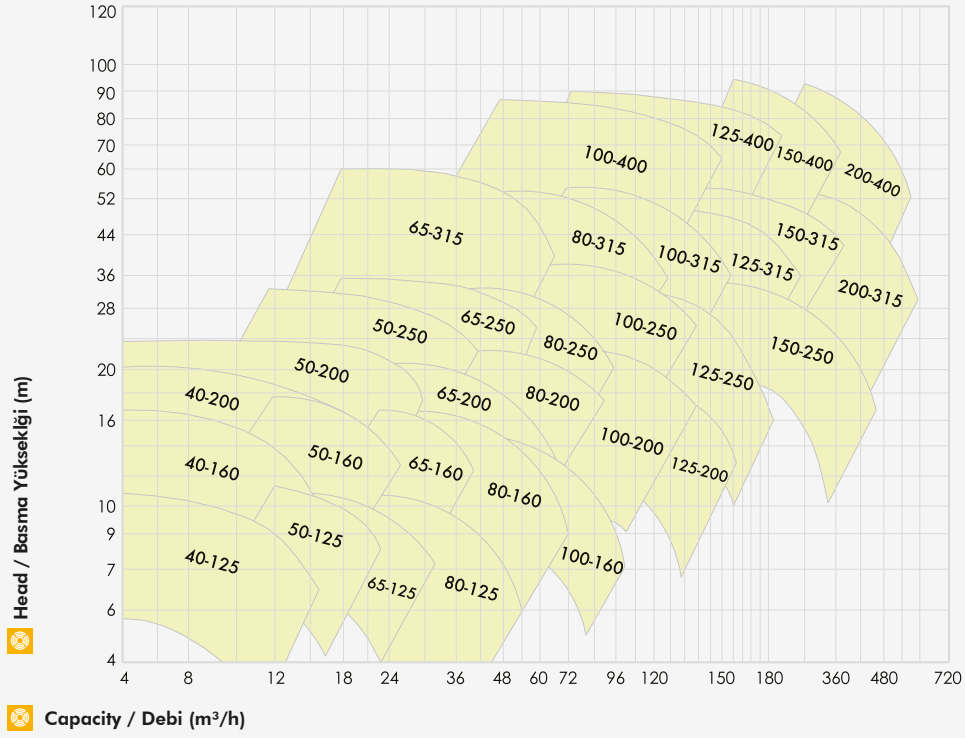

## 3500 rpm / (d/d) (60 Hz)

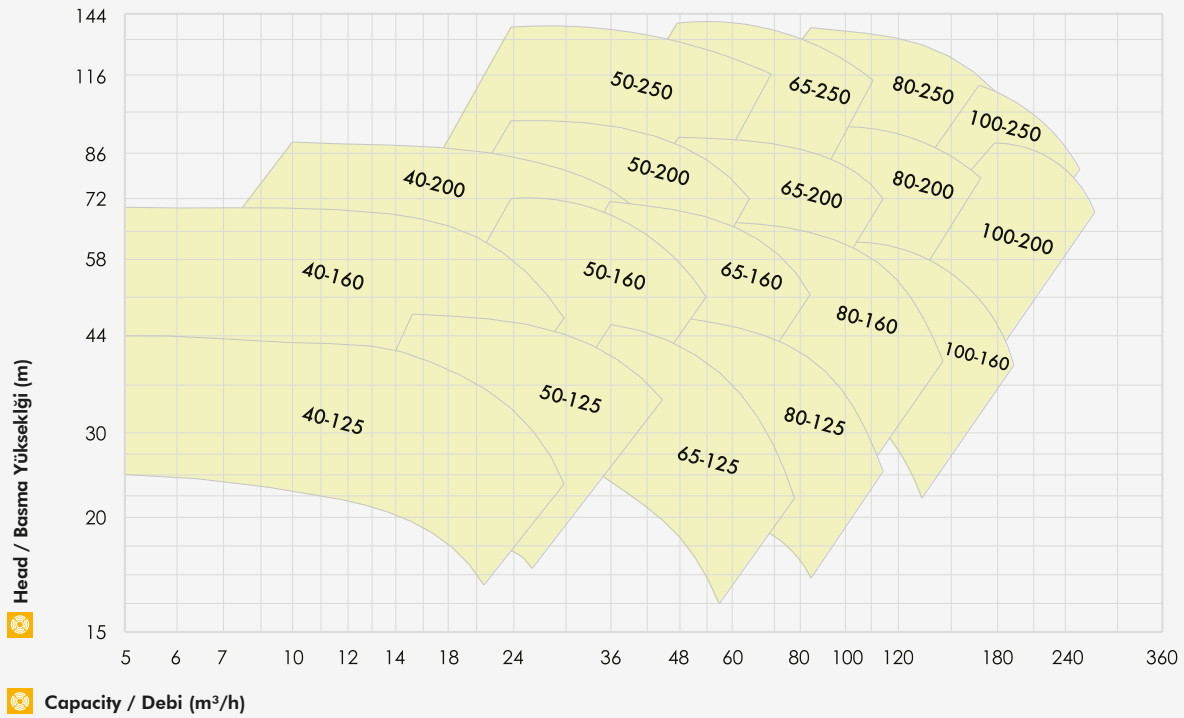

For detailed curves, use our selection program.

Detay eğriler için seçim programımızı kullanınız.

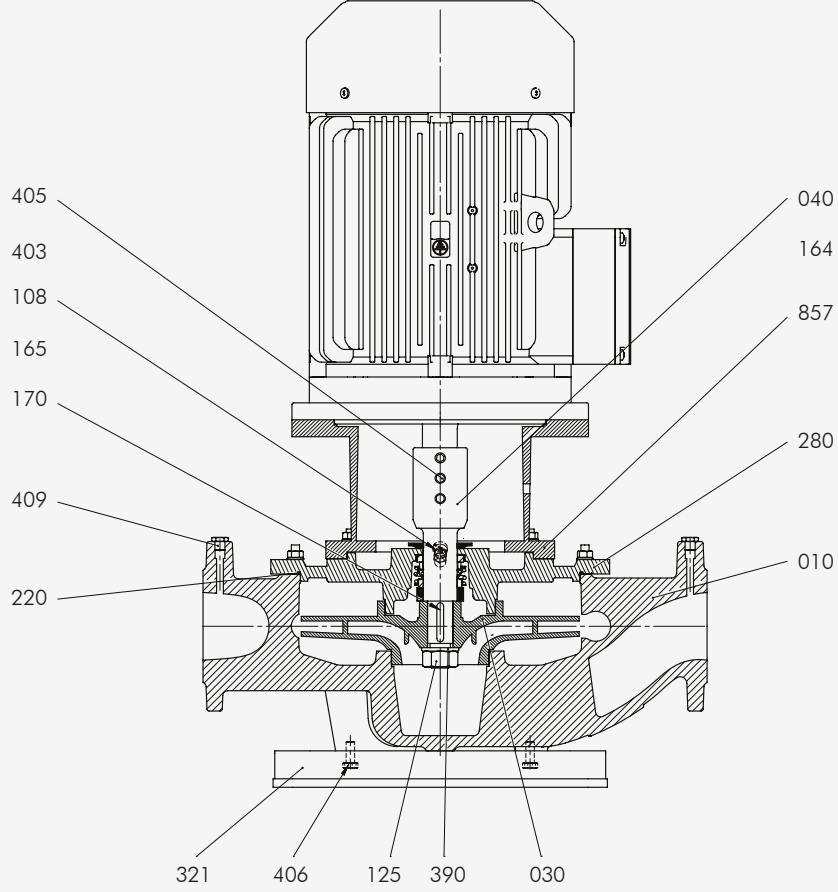

## Part List

## Parça Listesi

Volute Casing	010	Salyangoz Gövde
Impeller	030	Çark
Shaft	040	Mil
Air Purge	108	Hava Pürjörü
Nut	125	Somun
Mechanical Seal Setting Sleeve	164	Mekanik Salmastra Mesafe Burcu
Mechanical Seal	165	Mekanik Salmastra
Key	170	Kama
O-Ring	220	O-Ring
Seal Box	280	Salmastra Kutusu
Table	321	Tabla
Washer	390	Rondela
Throw Protection	403	Su Sıçratma Diski
Set Screw	405	Setskur
Connection Bolt	406	Bağlantı Civatası
Drain Plug	409	Boşaltma Tapası
Motor Carrier	857	Motor Taşıyıcı



1450 rpm / (d/d)

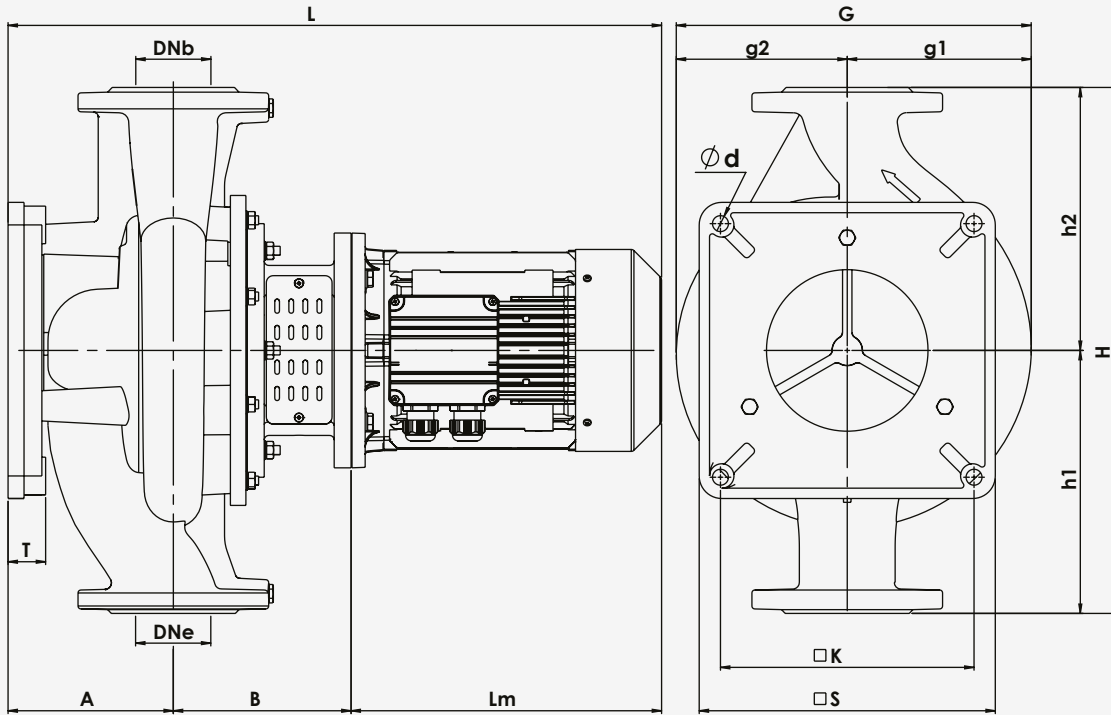

Pump Type Pompa tipi	Motor		Form	Dimensions / Ölçüler (mm)														Weight Ağırlık (kg)	
	kW	IEC		Outside Dimensions / Dış Ölçüler															
				DN <sub>e</sub> DN <sub>b</sub>	A	B	L <sub>m</sub>	L	T	H	h <sub>1</sub>	h <sub>2</sub>	G	g <sub>1</sub>	g <sub>2</sub>	S	K		Ød
40-125	0,37	71M	T1	40	101	152	210	463	26	300	160	140	208	108	100	200	160	14	34
40-160	0,37	71M	T1	40	101	149	210	460	26	340	180	160	232	122	110	200	160	14	37
40-160	0,55	80M	T1	40	101	183	234	518	26	340	180	160	232	122	110	200	160	14	42
40-160	0,75	80M	T1	40	101	183	234	518	26	340	180	160	232	122	110	200	160	14	43
40-200	0,55	80M	T2	40	103	183	234	520	28	380	200	180	275	140	135	255	219	14	52
40-200	0,75	80M	T2	40	103	183	234	520	28	380	200	180	275	140	135	255	219	14	53
40-200	1,1	90S	T2	40	103	183	275	561	28	380	200	180	275	140	135	255	219	14	57
50-125	0,37	71M	T1	50	116	154	210	480	26	300	160	140	213	110	103	200	160	14	36
50-125	0,55	80M	T1	50	116	164	234	514	26	300	160	140	213	110	103	200	160	14	40
50-160	0,37	71M	T1	50	116	149	210	475	26	340	180	160	243	125	118	200	160	14	40
50-160	0,55	80M	T1	50	116	184	234	534	26	340	180	160	243	125	118	200	160	14	45
50-160	0,75	80M	T1	50	116	184	234	534	26	340	180	160	243	125	118	200	160	14	47
50-160	1,1	90S	T1	50	116	184	275	575	26	340	180	160	243	125	118	200	160	14	50
50-200	0,75	80M	T2	50	118	183	234	535	28	425	225	200	281	145	136	255	219	14	56
50-200	1,1	90S	T2	50	118	183	275	576	28	425	225	200	281	145	136	255	219	14	60
50-200	1,5	90L	T2	50	118	183	275	576	28	425	225	200	281	145	136	255	219	14	62
50-200	2,2	100L	T2	50	118	184	310	612	28	425	225	200	281	145	136	255	219	14	68
50-250	1,5	90L	T2B	50	118	180	275	573	28	475	250	225	338	165	173	255	219	14	75
50-250	2,2	100L	T2B	50	118	180	310	608	28	475	250	225	338	165	173	255	219	14	82
50-250	3	100L	T2B	50	118	180	310	608	28	475	250	225	338	165	173	255	219	14	84

**1450 rpm / (d/d)**

Pump Type Pompa Tipi	Motor		Form	Dimensions / Ölçüler (mm)															Weight Ağırlık (kg)
	kW	IEC		Outside Dimensions / Dış Ölçüler															
				DN <sub>e</sub> DN <sub>b</sub>	A	B	Lm	L	T	H	h1	h2	G	g1	g2	S	K	Ød	
65-125	0,37	71M	T2	65	138	156	210	504	28	340	180	160	225	120	105	255	219	14	43
65-125	0,55	80M	T2	65	138	166	234	538	28	340	180	160	225	120	105	255	219	14	47
65-125	0,75	80M	T2	65	138	166	234	538	28	340	180	160	225	120	105	255	219	14	48
65-160	0,75	80M	T2	65	138	185	234	557	28	380	200	180	254	134	120	255	219	14	54
65-160	1,1	90S	T2	65	138	185	275	598	28	380	200	180	254	134	120	255	219	14	58
65-160	1,5	90L	T2	65	138	185	275	598	28	380	200	180	254	134	120	255	219	14	61
65-200	1,1	90S	T2B	65	138	185	275	598	28	475	250	225	300	160	140	255	219	14	70
65-200	1,5	90L	T2B	65	138	185	275	598	28	475	250	225	300	160	140	255	219	14	73
65-200	2,2	100L	T2B	65	138	186	310	634	28	475	250	225	300	160	140	255	219	14	79
65-200	3	100L	T2B	65	138	186	310	634	28	475	250	225	300	160	140	255	219	14	81
65-250	2,2	100L	T2B	65	138	187	310	635	28	475	250	225	340	176	164	255	219	14	86
65-250	3	100L	T2B	65	138	187	310	635	28	475	250	225	340	176	164	255	219	14	88
65-250	4	112M	T2B	65	138	187	330	655	28	475	250	225	340	176	164	255	219	14	96
65-250	5,5	132S	T2B	65	138	197	415	750	28	475	250	225	340	176	164	255	219	14	113
65-315	3	100L	T4A	65	170	192	310	672	40	560	280	280	418	216	202	395	350	18	125
65-315	4	112M	T4A	65	170	192	330	692	40	560	280	280	418	216	202	395	350	18	133
65-315	5,5	132S	T4A	65	170	205	415	790	40	560	280	280	418	216	202	395	350	18	150
65-315	7,5	132M	T4A	65	170	205	415	790	40	560	280	280	418	216	202	395	350	18	157
65-315	11	160M	T4A	65	170	245	495	910	40	560	280	280	418	216	202	395	350	18	185
80-125	0,37	71M	T2	80	158	158	210	526	28	380	200	180	252	138	114	255	219	14	49
80-125	0,55	80M	T2	80	158	168	234	560	28	380	200	180	252	138	114	255	219	14	52
80-125	0,75	80M	T2	80	158	168	234	560	28	380	200	180	252	138	114	255	219	14	54
80-125	1,1	90S	T2	80	158	168	275	601	28	380	200	180	252	138	114	255	219	14	58
80-160	0,75	80M	T2	80	158	190	234	582	28	425	225	200	283	155	128	255	219	14	60
80-160	1,1	90S	T2	80	158	190	275	623	28	425	225	200	283	155	128	255	219	14	64
80-160	1,5	90L	T2	80	158	190	275	623	28	425	225	200	283	155	128	255	219	14	66
80-160	2,2	100L	T2	80	158	190	310	658	28	425	225	200	283	155	128	255	219	14	74
80-200	1,5	90L	T2A	80	159	185	275	619	28	475	250	225	312	168	144	255	220	14	74
80-200	2,2	100L	T2A	80	159	187	310	656	28	475	250	225	312	168	144	255	220	14	79
80-200	3	100L	T2A	80	159	187	310	656	28	475	250	225	312	168	144	255	220	14	81
80-200	4	112M	T2A	80	159	187	330	676	28	475	250	225	312	168	144	255	220	14	89
80-250	2,2	100L	T3	80	176	189	310	675	36	560	280	280	378	196	182	315	270	17	106
80-250	3	100L	T3	80	176	189	310	675	36	560	280	280	378	196	182	315	270	17	107
80-250	4	112M	T3	80	176	189	330	695	36	560	280	280	378	196	182	315	270	17	115
80-250	5,5	132S	T3	80	176	202	415	793	36	560	280	280	378	196	182	315	270	17	132
80-315	5,5	132S	T4A	80	190	204	415	809	40	595	315	280	423	218	205	395	350	18	161
80-315	7,5	132M	T4A	80	190	204	415	809	40	595	315	280	423	218	205	395	350	18	169
80-315	11	160M	T4A	80	190	244	495	929	40	595	315	280	423	218	205	395	350	18	197
80-315	15	160L	T4A	80	190	244	495	929	40	595	315	280	423	218	205	395	350	18	209
100-160	1,5	90L	T2B	100	159	186	275	620	28	475	250	225	292	162	130	255	219	14	74
100-160	2,2	100L	T2B	100	159	186	310	655	28	475	250	225	292	162	130	255	219	14	80
100-160	3	100L	T2B	100	159	186	310	655	28	475	250	225	292	162	130	255	219	14	82



**1450 rpm / (d/d)**

Pump Type Pompa Tipi	Motor		Form	Dimensions / Ölçüler (mm)															Weight Ağırlık (kg)
	kW	IEC		Outside Dimensions / Dış Ölçüler															
				DN <sub>e</sub> DN <sub>b</sub>	A	B	Lm	L	T	H	h1	h2	G	g1	g2	S	K	Ød	
100-200	3	100L	T2B	100	198	193	310	701	28	525	275	250	358	191	167	255	219	14	98
100-200	4	112M	T2B	100	198	193	330	721	28	525	275	250	358	191	167	255	219	14	105
100-200	5,5	132S	T2B	100	198	207	415	820	28	525	275	250	358	191	167	255	219	14	122
100-200	7,5	132M	T2B	100	198	207	415	820	28	525	275	250	358	191	167	255	219	14	128
100-250	4	112M	T3	100	206	198	330	734	36	580	300	280	388	208	180	315	270	17	130
100-250	5,5	132S	T3	100	206	211	415	832	36	580	300	280	388	208	180	315	270	17	146
100-250	7,5	132M	T3	100	206	211	415	832	36	580	300	280	388	208	180	315	270	17	153
100-250	11	160M	T3	100	206	251	495	952	36	580	300	280	388	208	180	315	270	17	181
100-315	7,5	132M	T4B	100	200	207	415	822	40	670	355	315	455	240	215	395	350	18	184
100-315	11	160M	T4B	100	200	247	495	942	40	670	355	315	455	240	215	395	350	18	212
100-315	15	160L	T4B	100	200	247	495	942	40	670	355	315	455	240	215	395	350	18	223
100-315	18,5	180M	T4B	100	200	247	576	1023	40	670	355	315	455	240	215	395	350	18	293
100-400	15	160L	T4B	100	190	257	495	942	40	800	400	400	563	290	273	395	350	18	270
100-400	18,5	180M	T4B	100	190	257	576	1023	40	800	400	400	563	290	273	395	350	18	340
100-400	22	180L	T4B	100	190	257	576	1023	40	800	400	400	563	290	273	395	350	18	357
100-400	30	200L	T4B	100	190	257	643	1090	40	800	400	400	563	290	273	395	350	18	426
100-400	37	225S	T4B	100	190	287	688	1165	40	800	400	400	563	290	273	395	350	18	488
125-200	3	100L	T4B	125	220	214	310	744	40	560	280	280	405	208	197	395	350	18	130
125-200	4	112M	T4B	125	220	215	330	765	40	560	280	280	405	208	197	395	350	18	140
125-200	5,5	132S	T4B	125	220	228	415	863	40	560	280	280	405	208	197	395	350	18	157
125-200	7,5	132M	T4B	125	220	228	415	863	40	560	280	280	405	208	197	395	350	18	165
125-250	5,5	132S	T4	125	220	232	415	867	40	630	315	315	410	215	195	395	350	18	170
125-250	7,5	132M	T4	125	220	232	415	867	40	630	315	315	410	215	195	395	350	18	175
125-250	11	160M	T4	125	220	272	495	987	40	630	315	315	410	215	195	395	350	18	203
125-250	15	160L	T4	125	220	272	495	987	40	630	315	315	410	215	195	395	350	18	215
125-315	11	160M	T4B	125	200	275	495	970	40	710	355	355	493	261	232	395	350	18	235
125-315	15	160L	T4B	125	200	275	495	970	40	710	355	355	493	261	232	395	350	18	245
125-315	18,5	180M	T4B	125	200	275	576	1051	40	710	355	355	493	261	232	395	350	18	316
125-315	22	180L	T4B	125	200	275	576	1051	40	710	355	355	493	261	232	395	350	18	333
125-315	30	200L	T4B	125	200	275	643	1118	40	710	355	355	493	261	232	395	350	18	405
125-400	22	180L	T4B	125	200	282	576	1058	40	800	400	400	566	292	274	395	350	18	360
125-400	30	200L	T4B	125	200	282	643	1125	40	800	400	400	566	292	274	395	350	18	430
125-400	37	225S	T4B	125	200	312	688	1200	40	800	400	400	566	292	274	395	350	18	492
125-400	45	225M	T4B	125	200	312	688	1200	40	800	400	400	566	292	274	395	350	18	530
150-250	11	160M	T5	150	225	302	495	1022	45	710	355	355	482	258	224	440	380	23	250
150-250	15	160L	T5	150	225	302	495	1022	45	710	355	355	482	258	224	440	380	23	305
150-250	18,5	180M	T5	150	225	302	576	1103	45	710	355	355	482	258	224	440	380	23	330
150-250	22	180L	T5	150	225	302	576	1103	45	710	355	355	482	258	224	440	380	23	350
150-315	15	160L	T5A	150	222	317	495	1034	42	710	355	355	555	295	260	440	380	23	286
150-315	18,5	180M	T5A	150	222	317	576	1115	42	710	355	355	555	295	260	440	380	23	355
150-315	22	180L	T5A	150	222	317	576	1115	42	710	355	355	555	295	260	440	380	23	373
150-315	30	200L	T5A	150	222	317	643	1182	42	710	355	355	555	295	260	440	380	23	395
150-315	37	225S	T5A	150	222	347	688	1257	42	710	355	355	555	295	260	440	380	23	420



**1450 rpm / (d/d)**

Pump Type Pompa Tipi	Motor		Form	Dimensions / Ölçüler (mm)														Weight Ağırlık (kg)	
	kW	IEC		Outside Dimensions / Dış Ölçüler															
				DN <sub>e</sub> DN <sub>b</sub>	A	B	Lm	L	T	H	h1	h2	G	g1	g2	S	K		Ød
150-400	37	225S	T5A	150	222	345	688	1255	42	800	400	400	618	320	298	440	380	23	524
150-400	45	225M	T5A	150	222	345	688	1255	42	800	400	400	618	320	298	440	380	23	560
150-400	55	250M	T5A	150	222	345	756	1323	42	800	400	400	618	320	298	440	380	23	660
150-400	75	280M	T5A	150	222	345	876	1323	42	800	400	400	618	320	298	440	380	23	850
200-315	18,5	180M	T5A	200	242	362	576	1180	42	800	350	450	554	300	254	440	380	23	364
200-315	22	180L	T5A	200	242	362	576	1180	42	800	350	450	554	300	254	440	380	23	380
200-315	30	200L	T5A	200	242	362	641	1245	42	800	350	450	554	300	254	440	380	23	404
200-315	37	225S	T5A	200	242	392	686	1320	42	800	350	450	554	300	254	440	380	23	428
200-315	45	225M	T5A	200	242	392	686	1320	42	800	350	450	554	300	254	440	380	23	547
200-400	37	225S	T5A	200	242	388	688	1318	42	900	400	500	615	325	290	440	380	23	558
200-400	45	225M	T5A	200	242	388	688	1318	42	900	400	500	615	325	290	440	380	23	594
200-400	55	250M	T5A	200	242	388	756	1386	42	900	400	500	615	325	290	440	380	23	834
200-400	75	280M	T5A	200	242	388	876	1506	42	900	400	500	615	325	290	440	380	23	958
200-400	90	280M	T5A	200	242	388	876	1506	42	900	400	500	615	325	290	440	380	23	994

○ Please contact for 1750 rpm (60Hz) dimensions. Dimensions can be change according to motor brand.

1750 rpm (60Hz) ölçüler için iletişime geçiniz. Motor markasına göre boyutlar değişebilir. ○

**2900 rpm / (d/d)**

Pump Type Pompa Tipi	Motor		Form	Dimensions / Ölçüler (mm)														Weight Ağırlık (kg)	
	kW	IEC		Outside Dimensions / Dış Ölçüler															
				DN <sub>e</sub> DN <sub>b</sub>	A	B	Lm	L	T	H	h1	h2	G	g1	g2	S	K		Ød
40-125	1,1	80M	T1	40	101	162	234	497	26	300	160	140	208	108	100	200	160	14	39
40-125	1,5	90S	T1	40	101	162	275	538	26	300	160	140	208	108	100	200	160	14	44
40-125	2,2	90L	T1	40	101	162	275	538	26	300	160	140	208	108	100	200	160	14	45
40-125	3	100L	T1	40	101	183	310	594	26	300	160	140	208	108	100	200	160	14	53
40-160	3	100L	T1	40	101	183	310	594	26	340	180	160	232	122	110	200	160	14	55
40-160	4	112M	T1	40	101	183	330	614	26	340	180	160	232	122	110	200	160	14	60
40-160	5,5	132S	T1	40	101	193	415	709	26	340	180	160	232	122	110	200	160	14	77
40-200	4	112M	T2	40	103	184	330	617	28	380	200	180	275	140	135	255	219	14	69
40-200	5,5	132S	T2	40	103	196	415	714	28	380	200	180	275	140	135	255	219	14	87
40-200	7,5	132S	T2	40	103	196	415	714	28	380	200	180	275	140	135	255	219	14	91
40-200	11	160M	T2	40	103	236	495	834	28	380	200	180	275	140	135	255	219	14	125
50-125	1,5	90S	T1	50	116	164	275	555	26	300	160	140	213	110	103	200	160	14	44
50-125	2,2	90L	T1	50	116	164	275	555	26	300	160	140	213	110	103	200	160	14	46
50-125	3	100L	T1	50	116	186	310	612	26	300	160	140	213	110	103	200	160	14	54
50-125	4	112M	T1	50	116	186	330	632	26	300	160	140	213	110	103	200	160	14	59
50-125	5,5	132S	T1	50	116	198	415	729	26	300	160	140	213	110	103	200	160	14	77



**2900 rpm / (d/d)**

Pump Type Pompa Tipi	Motor		Form	Dimensions / Ölçüler (mm)															Weight Ağırlık (kg)
	kW	IEC		Outside Dimensions / Dış Ölçüler															
				DN <sub>e</sub> DN <sub>b</sub>	A	B	Lm	L	T	H	h1	h2	G	g1	g2	S	K	Ød	
50-160	3	100L	T1	50	116	184	310	610	26	340	180	160	243	125	118	200	160	14	58
50-160	4	112M	T1	50	116	184	330	630	26	340	180	160	243	125	118	200	160	14	63
50-160	5,5	132S	T1	50	116	194	415	725	26	340	180	160	243	125	118	200	160	14	80
50-160	7,5	132S	T1	50	116	194	415	725	26	340	180	160	243	125	118	200	160	14	85
50-160	11	160M	T1	50	116	238	495	849	26	340	180	160	243	125	118	200	160	14	120
50-200	7,5	132S	T2	50	118	196	415	729	28	425	225	200	281	145	136	255	219	14	94
50-200	11	160M	T2	50	118	236	495	849	28	425	225	200	281	145	136	255	219	14	127
50-200	15	160M	T2	50	118	236	495	849	28	425	225	200	281	145	136	255	219	14	132
50-250	11	160M	T2B	50	118	234	495	847	28	475	250	225	338	165	173	255	220	14	141
50-250	15	160M	T2B	50	118	234	495	847	28	475	250	225	338	165	173	255	220	14	147
50-250	18,5	160L	T2B	50	118	234	495	847	28	475	250	225	338	165	173	255	220	14	159
50-250	22	180M	T2B	50	118	234	576	928	28	475	250	225	338	165	173	255	220	14	233
50-250	30	200L	T2B	50	118	234	643	995	28	475	250	225	338	165	173	255	220	14	305
65-125	3	100L	T2	65	138	188	310	636	28	340	180	160	225	120	105	255	219	14	61
65-125	4	112M	T2	65	138	188	330	656	28	340	180	160	225	120	105	255	219	14	66
65-125	5,5	132S	T2	65	138	200	415	753	28	340	180	160	225	120	105	255	219	14	84
65-125	7,5	132S	T2	65	138	200	415	753	28	340	180	160	225	120	105	255	219	14	88
65-160	5,5	132S	T2	65	138	195	415	748	28	380	200	180	254	134	120	255	219	14	88
65-160	7,5	132S	T2	65	138	195	415	748	28	380	200	180	254	134	120	255	219	14	92
65-160	11	160M	T2	65	138	238	495	871	28	380	200	180	254	134	120	255	219	14	127
65-200	11	160M	T2B	65	138	238	495	871	28	475	250	225	300	160	140	255	219	14	138
65-200	15	160M	T2B	65	138	238	495	871	28	475	250	225	300	160	140	255	219	14	143
65-200	18,5	160L	TB2	65	138	238	495	871	28	475	250	225	300	160	140	255	219	14	155
65-200	22	180M	T2B	65	138	238	576	952	28	475	250	225	300	160	140	255	219	14	230
65-250	15	160M	T2B	65	138	241	495	874	28	475	250	225	340	176	164	255	219	14	151
65-250	18,5	160L	T2B	65	138	241	495	874	28	475	250	225	340	176	164	255	219	14	163
65-250	22	180M	T2B	65	138	241	576	955	28	475	250	225	340	176	164	255	219	14	237
65-250	30	200L	T2B	65	138	241	643	1022	28	475	250	225	340	176	164	255	219	14	309
65-250	37	200L	T2B	65	138	241	643	1022	28	475	250	225	340	176	164	255	219	14	319
80-125	4	112M	T2	80	158	190	330	678	28	380	200	180	252	138	114	255	219	14	71
80-125	5,5	132S	T2	80	158	202	415	775	28	380	200	180	252	138	114	255	219	14	90
80-125	7,5	132S	T2	80	158	202	415	775	28	380	200	180	252	138	114	255	219	14	93
80-125	11	160M	T2	80	158	242	495	895	28	380	200	180	252	138	114	255	219	14	125
80-160	11	160M	T2	80	158	243	495	896	28	425	225	200	283	155	128	255	219	14	132
80-160	15	160M	T2	80	158	243	495	896	28	425	225	200	283	155	128	255	219	14	138
80-160	18,5	160L	T2	80	158	243	495	896	28	425	225	200	283	155	128	255	219	14	150
80-200	15	160M	T2A	80	159	239	495	893	28	475	250	225	312	168	144	255	220	14	143
80-200	18,5	160L	T2A	80	159	239	495	893	28	475	250	225	312	168	144	255	220	14	155
80-200	22	180M	T2A	80	159	239	576	974	28	475	250	225	312	168	144	255	220	14	230
80-200	30	200L	T2A	80	159	239	643	1041	28	475	250	225	312	168	144	255	220	14	299



**2900 rpm / (d/d)**

Pump Type Pompa Tipi	Motor		Form	Dimensions / Ölçüler (mm)															Weight Ağırlık (kg)
	kW	IEC		Outside Dimensions / Dış Ölçüler															
				DN <sub>e</sub> DN <sub>b</sub>	A	B	Lm	L	T	H	h1	h2	G	g1	g2	S	K	Ød	
80-250	22	180M	T3	80	176	243	576	995	36	560	280	280	378	196	182	315	270	17	255
80-250	30	200L	T3	80	176	243	643	1062	36	560	280	280	378	196	182	315	270	17	325
80-250	37	200L	T3	80	176	243	643	1062	36	560	280	280	378	196	182	315	270	17	335
80-250	45	225M	T3	80	176	243	688	1107	36	560	280	280	378	196	182	315	270	17	410
80-250	55	250M	T3	80	176	273	756	1205	36	560	280	280	378	196	182	315	270	17	500
100-160	11	160M	T2B	100	159	240	495	894	28	475	250	225	292	162	130	255	219	14	140
100-160	15	160M	T2B	100	159	240	495	894	28	475	250	225	292	162	130	255	219	14	146
100-160	18,5	160L	T2B	100	159	240	495	894	28	475	250	225	292	162	130	255	219	14	157
100-160	22	180M	T2B	100	159	240	576	975	28	475	250	225	292	162	130	255	219	14	232
100-200	22	180M	T2B	100	198	247	576	1021	28	525	275	250	358	191	167	255	219	14	244
100-200	30	200L	T2B	100	198	247	643	1088	28	525	275	250	358	191	167	255	219	14	314
100-200	37	200L	T2B	100	198	247	643	1088	28	525	275	250	358	191	167	255	219	14	325
100-200	45	225M	T2B	100	198	247	688	1133	28	525	275	250	358	191	167	255	219	14	400
100-250	37	200L	T3	100	206	251	643	1100	36	580	300	280	388	208	180	315	270	17	346
100-250	45	225M	T3	100	206	251	688	1145	36	580	300	280	388	208	180	315	270	17	420
100-250	55	225M	T3	100	206	281	756	1273	36	580	300	280	388	208	180	315	270	17	511

○ Please contact for 3500 rpm (60Hz) dimensions. Dimensions can be change according to motor brand.

3500 rpm (60Hz) ölçüler için iletişime geçiniz. Motor markasına göre boyutlar değişebilir. ○



## FLANGE DIMENSIONS

## FLANŞ ÖLÇÜLERİ

Pump Type Pompa Tipi	Suction & Discharge / Emme & Basma (PN 16)			
	Df	k	s	n
40	150	110	19	4
50	165	125	19	4
65	185	145	19	4
80	200	160	19	8
100	220	180	19	8
125	250	210	19	8
150	285	240	23	8
200	340	295	23	12

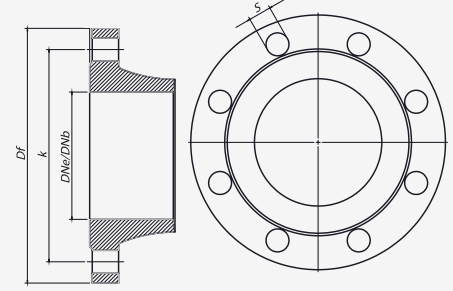

- TS EN 1092      ○ "n" Number of Holes / Delik Sayısı

## SEAL SOLUTIONS

## SALMASTRA ÇÖZÜMLERİ

Packing Type / Salmastra Tipi	Packing Specifications / Salmastra Özellikleri	
	Temperature / Sıcaklık	Pressure / Basınç
eMG1	t = -20 °C ... +140 °C	P = 16 Bar (230 PSI)
H12N	t = +100 °C ... +140 °C	P = 25 Bar (363 PSI)
M7N	t = -20 °C ... +220 °C	P = 25 Bar (363 PSI)
M37	t = -20 °C ... +180 °C	P = 10 Bar (145 PSI)
H7N	t = -50 °C ... +220 °C	P = 80 Bar (1160 PSI)

- Note: Above datas mentioned according to BURGMANN Brand.  
Packing can be changed according to customer request.

Different seal application can be used according to liquid specification.

- Not: BURGMANN marka mekanik salmastraya göre belirlenmiştir. ○  
Müşteri isteğine göre salmastra marka değişikliği yapılabilir.

Akışkan cinsi ve çalışma şartlarına göre farklı salmastra seçenekleri uygulanabilir.





**50 YIL**  
**50 Years**

50 Yıldır Yanınızdayız  
We Have Been With You For 50 Years

**DÖKÜM**  
**Casting**

**Pik Döküm**  
Cast Iron

**Sfero Döküm**  
Ductile Cast Iron

**Paslanmaz Çelik**  
Stainless Steel

**Duplex Çelik**  
Duplex Steel

**Çelik**  
Steel

**Bronz**  
Bronze



**İŞLEME**  
**Machining**

CNC - Hassas İşleme - Kalite Kontrol  
CNC - Sensitive Machining - Quality Control



**KALİTE KONTROL**  
**Quality Control**



**DENEY**  
**Testing**

Her Ürün İle Test Raporu Teslimi  
Supply Testing Raport For Each Pump



**STOK**  
**Stock**

1.500.000 Kg İşlenmiş Parça  
1.500.000 Kg Machined Part



**I'M**  
**PUMP**  
**TECH**  
**NOLOGY**



A series of horizontal dashed lines for writing.

A series of horizontal dashed lines for writing.

A series of horizontal dashed lines for writing.



**SEMPA**

**TKF-I SERIES**

DPT SERIES

ARS-D SERIES

ARS SERIES

TKF-M SERIES

SP SERIES

TKF-KE SERIES