

# NORM<sup>®</sup>



## NKY Series Hot Oil Pumps



## HOT OIL PUMPS

### NKY Series Pumps;

It is suitable for pumping heat transfer oils and low viscosity industrial oils without containing any abrasive parts in.

### Operation Details

Suction Flange	: DN 50... DN 200
Discharge Flange	: DN 32... DN 125
Q (Flow)	: 350 m <sup>3</sup> /h (max.)
H (Head)	: 105 m (max.)
Motor (Rotation Per Minute)	: 2900 rpm - 1450 rpm
t (Operating Temperature)	: 320 ° C (max.)
Pd (Body Pressure Pmax)	: 16 bars
Cooling Type	: With Air



### Technical Specifications

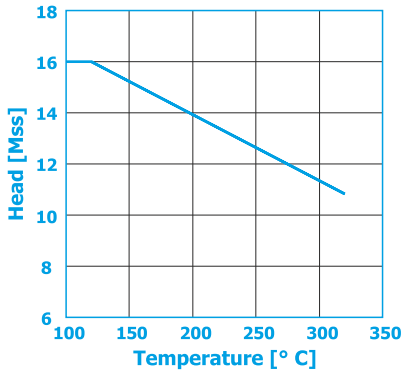

- Horizontal shaft, volute, single-stage, end-suction, air-cooled, closed impeller centrifugal pumps.
- Suction and discharge flanges conform to EN 1092-2 / PN 16.
- All of the impellers have been dynamically balanced according to ISO 1940 class 6.3.
- Bearing group, seal bearing, pump shaft and the impeller can be dismantled without separating the volute off the piping installation thanks to the design that can be dismantled from the back.

### Sealing of Shaft

- High temperature resistant single-acting type and mechanical seal is used.

### Direction of Rotation

- The direction of rotation of pump is clockwise when viewed from the motor side.

### Pump Description

Pump Type	NKY
Discharge Flange (DN)	125 / 200
Impeller Nominal Diameter (mm)	125 / 200

## PERFORMANCE AREAS

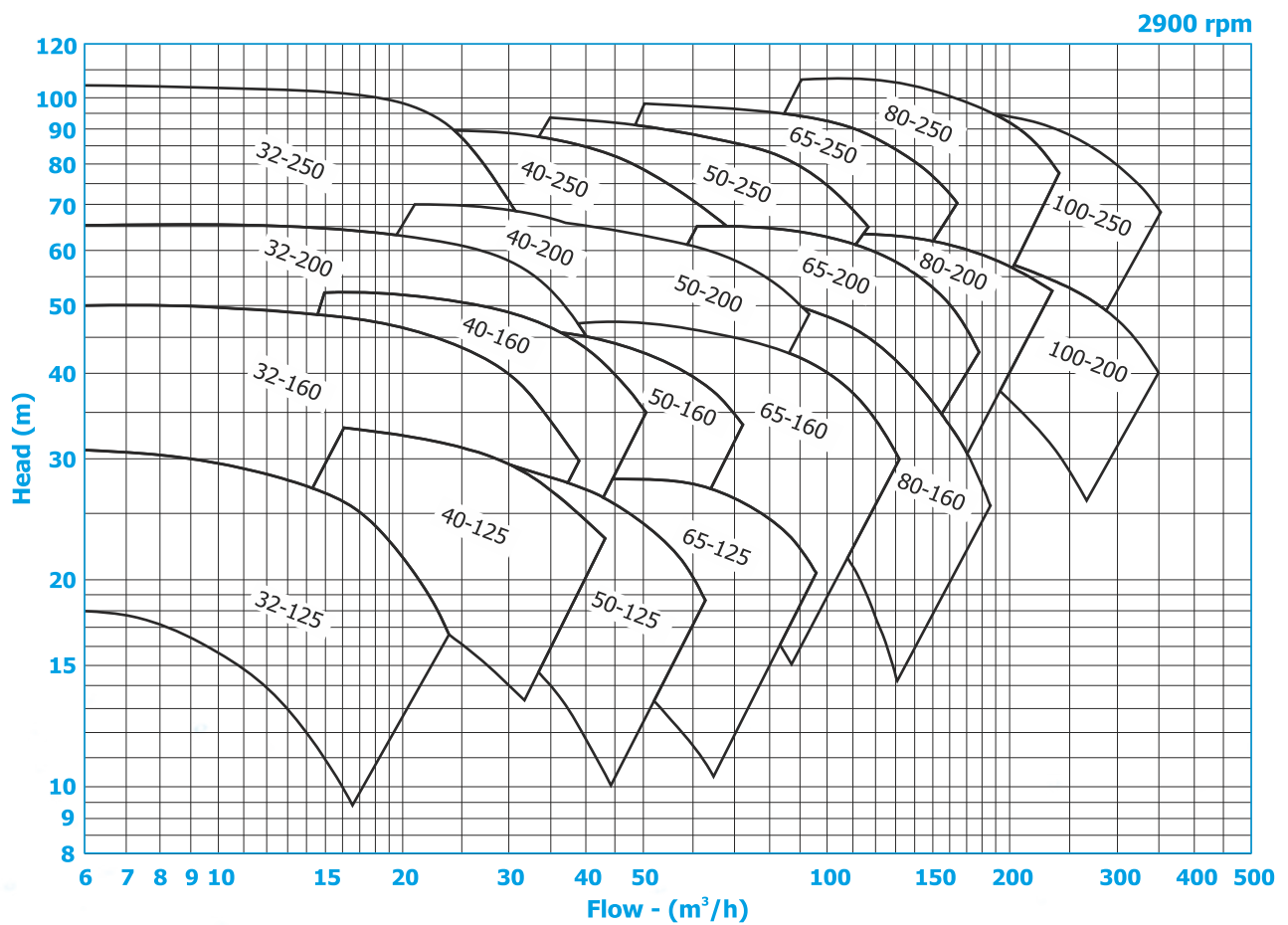
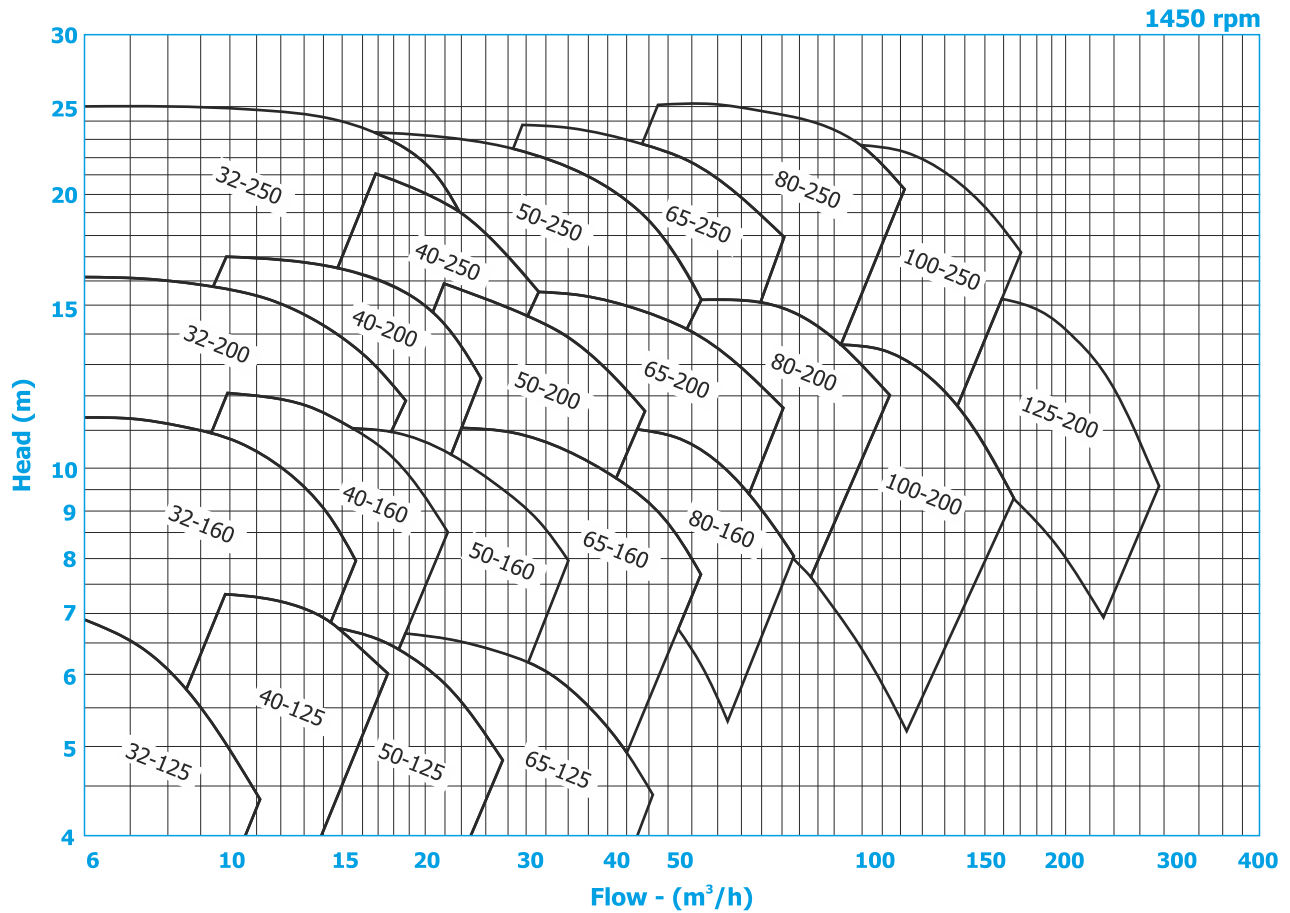

## TECHNICAL INFORMATION

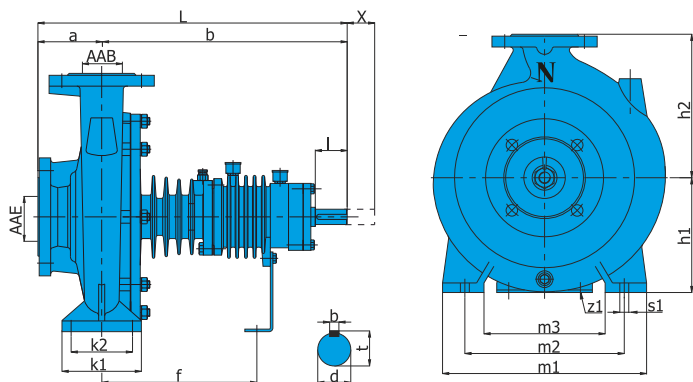

### Material Selection Table

Parts List	0.6025	0.7040	1.4408	1.4021	1.4401
Volute Body		●	○		
Housing Cover		●	○		
Impeller	●	○	○		
Shaft				●	○
Bearing Races	●	○	○		
Wear Ring (Body)	○	○	○		
Wear Plate	○	●	○		
Mechanical Seal	EN 12756 / DIN 24960				

● Standard manufacturing ○ Optional

### Pump Dimensions

Pump Type	Dimensions (mm)																		
	AAE	AAB	a	b	L	h1	h2	k1	k2	m1	m2	m3	z1	f	d	l	t	b	x
32 - 125	50	32	80	385	465	112	140	100	70	190	140	90	14	285	25	57	28	8	30
40 - 125	65	40	80	385	465	112	140	100	70	190	160	90	14	285	25	57	28	8	30
50 - 125	65	50	100	385	485	132	160	100	70	245	190	140	14	285	25	57	28	8	30
65 - 125	80	65	100	385	485	160	180	125	95	280	212	150	14	285	25	57	28	8	30
32 - 160	50	32	80	385	465	132	160	100	70	245	190	145	14	285	25	57	28	8	30
40 - 160	65	40	80	385	465	132	160	100	70	245	190	145	14	285	25	57	28	8	30
50 - 160	65	50	100	385	485	160	180	100	70	245	212	145	14	285	25	57	28	8	30
65 - 160	80	65	100	395	485	160	200	125	95	280	212	150	14	285	25	57	28	8	30
80 - 160	100	80	125	395	520	180	225	125	95	320	250	190	14	295	25	57	28	8	30
100 - 160	125	100	125	385	520	200	280	160	120	360	280	200	18	295	25	57	28	8	30
32 - 200	50	32	80	385	465	160	180	100	70	240	190	140	14	285	25	57	28	8	50
40 - 200	65	40	100	385	485	160	180	100	70	266	212	166	14	285	25	57	28	8	50
50 - 200	65	50	100	385	485	160	200	100	70	266	212	166	14	285	25	57	28	8	50
65 - 200	80	65	100	385	485	180	225	125	95	320	250	190	14	285	25	57	28	8	50
80 - 200	100	80	125	500	625	180	250	125	95	345	280	215	14	355	35	80	38	10	80
100 - 200	125	100	125	505	630	200	280	160	120	360	280	200	18	359	35	80	38	10	80
125 - 200	150	125	140	505	645	250	315	165	120	390	310	230	18	359	35	80	38	10	80
150 - 200	200	150	160	515	675	280	355	200	150	500	400	300	24	369	35	80	38	10	80
32 - 250	50	32	100	385	485	180	225	125	95	320	250	190	14	285	25	57	28	8	50
40 - 250	65	40	100	385	485	180	225	125	95	320	250	190	14	285	25	57	28	8	50
50 - 250	65	50	100	385	485	180	225	125	95	320	250	190	14	285	25	57	28	8	50
65 - 250	80	65	100	495	595	200	250	160	120	360	280	200	18	350	35	80	38	10	80
80 - 250	100	80	125	495	620	200	280	160	120	400	315	240	18	350	35	80	38	10	80
100 - 250	125	100	140	500	640	225	280	160	110	400	315	240	18	350	35	80	38	10	80

\* The minimum spacing between the motor and pump shafts required in order to be able to take rotor assembly off its seat (application of intermediate piece of coupling) without removing the electric motor and pump volute of the pump.

### Flange Dimensions

Pump Type	Suction (PN 16)						Discharge (PN 16)					
	ABe	D2	D1	x	z	b	ABb	D2	D1	x	z	b
32	50	165	125	18	4	20	32	140	100	18	4	18
40	65	185	145	18	4	20	40	150	110	18	4	18
50	65	185	145	18	4	20	50	165	125	18	4	20
65	80	200	160	18	8	22	65	185	145	18	4	20
80	100	220	180	18	8	24	80	200	160	18	8	22
100	125	250	210	18	8	26	100	220	180	18	8	24
125	150	285	240	23	8	26	125	250	210	18	8	26

" z " number of holes

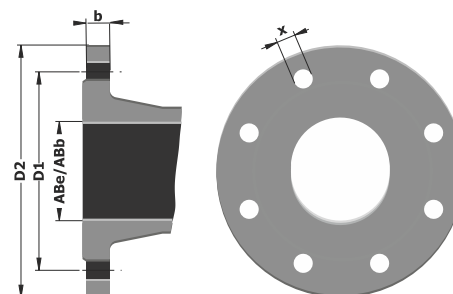

## SECTIONAL DRAWING

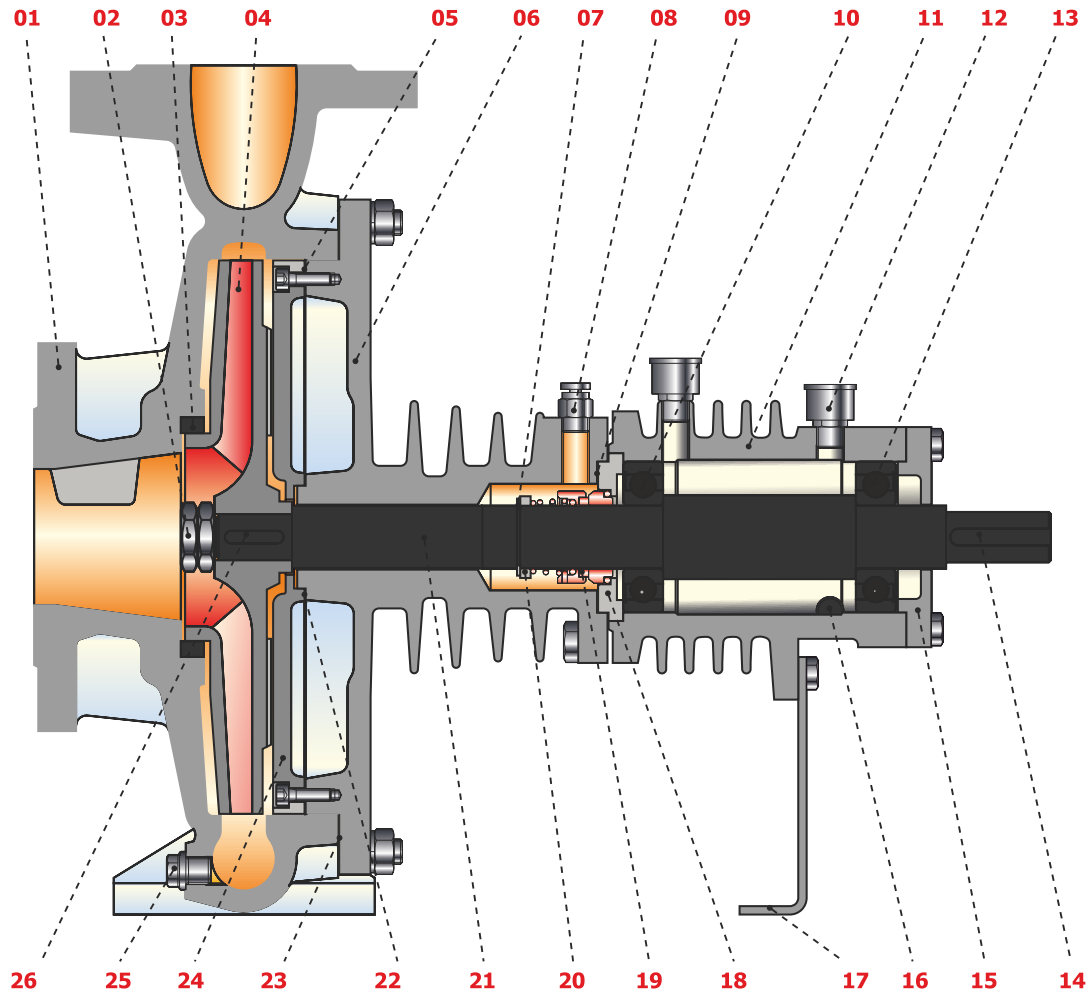

### Parts List

<b>01</b>	Volute Body	<b>10</b>	Ball Bearing	<b>19</b>	Mechanical Seal
<b>02</b>	Impeller Nut	<b>11</b>	Bearing Races	<b>20</b>	Spacer (Mechanical Seal)
<b>03</b>	Wear Ring	<b>12</b>	Grease Nipple	<b>21</b>	Shaft
<b>04</b>	Impeller	<b>13</b>	Ball Bearing	<b>22</b>	Seal (Wear Plates)
<b>05</b>	Seal (Wear Plates)	<b>14</b>	Coupling Key	<b>23</b>	Gasket (Body)
<b>06</b>	Housing Cover	<b>15</b>	Bearing Cap	<b>24</b>	Wear Plate
<b>07</b>	Retainer	<b>16</b>	Grease Drain Plug	<b>25</b>	Drain Plug
<b>08</b>	Air Bleed Plug	<b>17</b>	Support Foot	<b>26</b>	Impeller Key
<b>09</b>	Gasket Mechanical Seal Cover	<b>18</b>	Mechanical Seal Cover		

### Material Options

Description	DIN 17007	EN-DIN	ASTM
Cast Iron	0.6025	GJL-250 (GG 25)	A 48 Class 40-B
Nodular Cast Iron	0.7040	GJS-400-15 (GGG 40)	A 536 Gr. 60-40-18
Chrome-Nickel Molybdenum, Steel Casting	1.4408	G-X5 Cr Ni Mo 19-11-2	A 351/743/744 in Gr. CF8MA
Chromed Steel	1.4021	X20 Cr13	A 276 Type 420
Chrome-Nickel Molybdenum Steel	1.4401	X5 Cr Ni Mo 17-12-2	A 276 Type 316



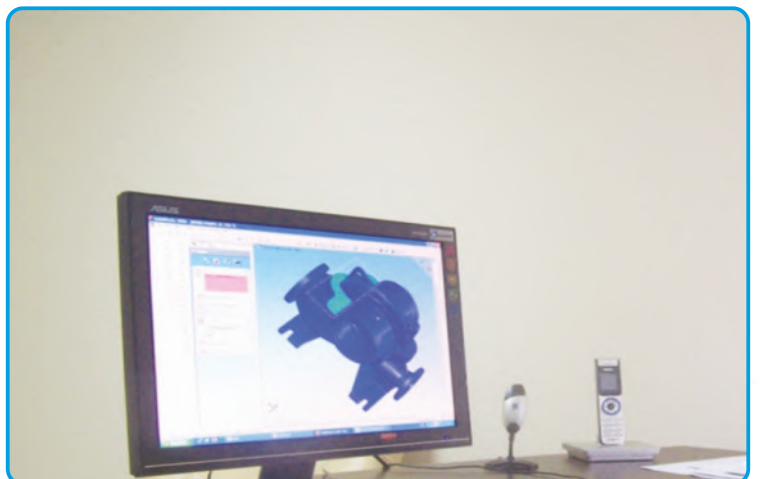
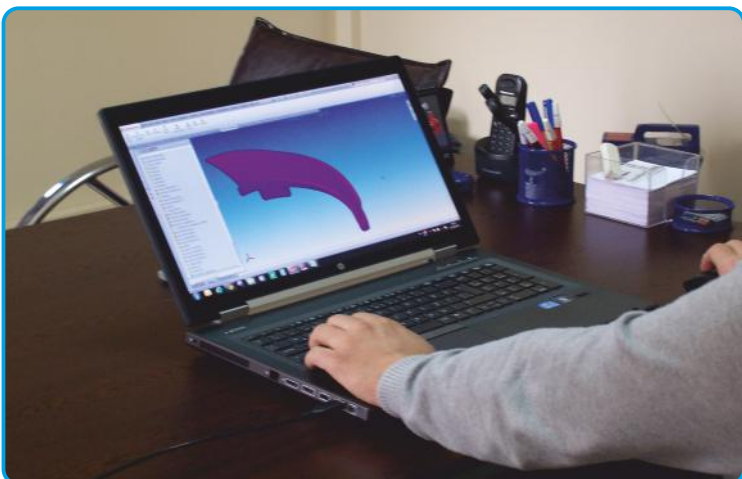
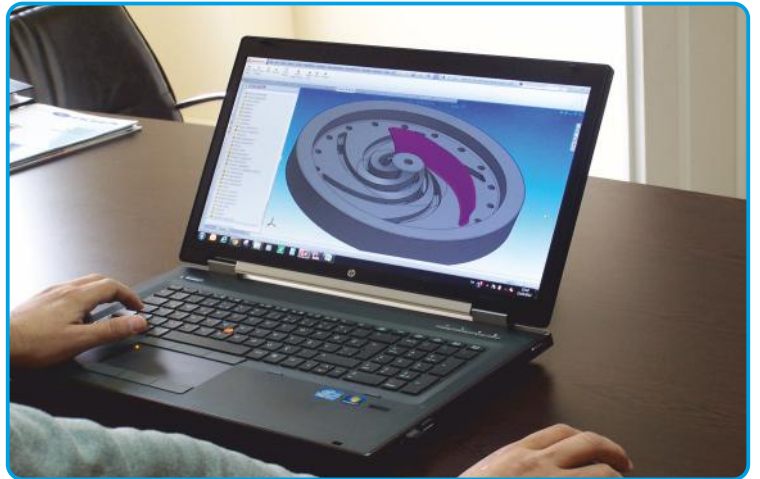
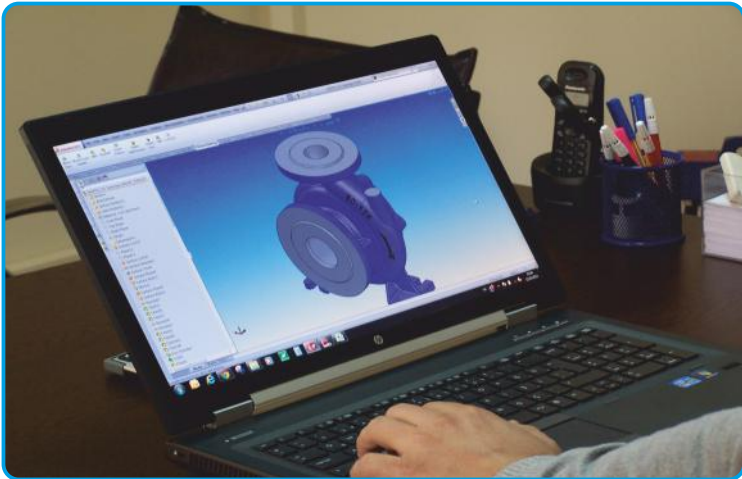

# NORM®



## NORM®

NORM HİDROFOR POMPA SAN. TİC. LTD. ŞTİ.

Uzundere Mevkii, Mecidiye Mah. Ağrı Cad. İkbal Sok.

No: 46/A 34930 Sultanbeyli - İSTANBUL - TURKEY

Tel : +90 216 496 71 05 (4 hat) Fax: +90 216 496 71 09

Tel : +90 216 398 54 33-36 Fax: +90 216 496 70 27

[www.normpumps.com.tr](http://www.normpumps.com.tr) • [info@normpumps.com.tr](mailto:info@normpumps.com.tr)

[www.normpompa.com.tr](http://www.normpompa.com.tr)

