

Application

- Small electrical irrigation and drainage equipments
- Particularly applied in urban well water pumping, field irrigation and drainage, garden irrigation and household water supply, as well as drainage of industrial accumulated water, water supply and drainage for construction, livestock breeding, etc.

Pump

- Stainless steel pump body
- Max. immersion depth: 5 m
- Max. liquid temperature: +40°C
- Liquid pH value: 4 – 10
- Max. liquid density: 1.03x10³ kg/m³

Motor

- Copper winding
- Built-in thermal protector
- Stainless steel welded shaft
- Insulation class: B
- Protection class: IP68

Identification Codes

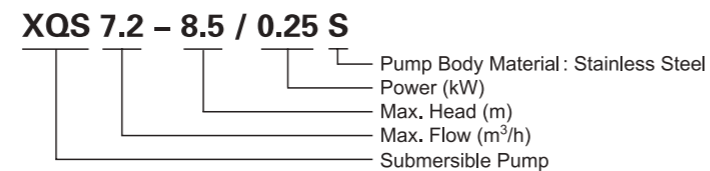

Hydraulic Performance Curves

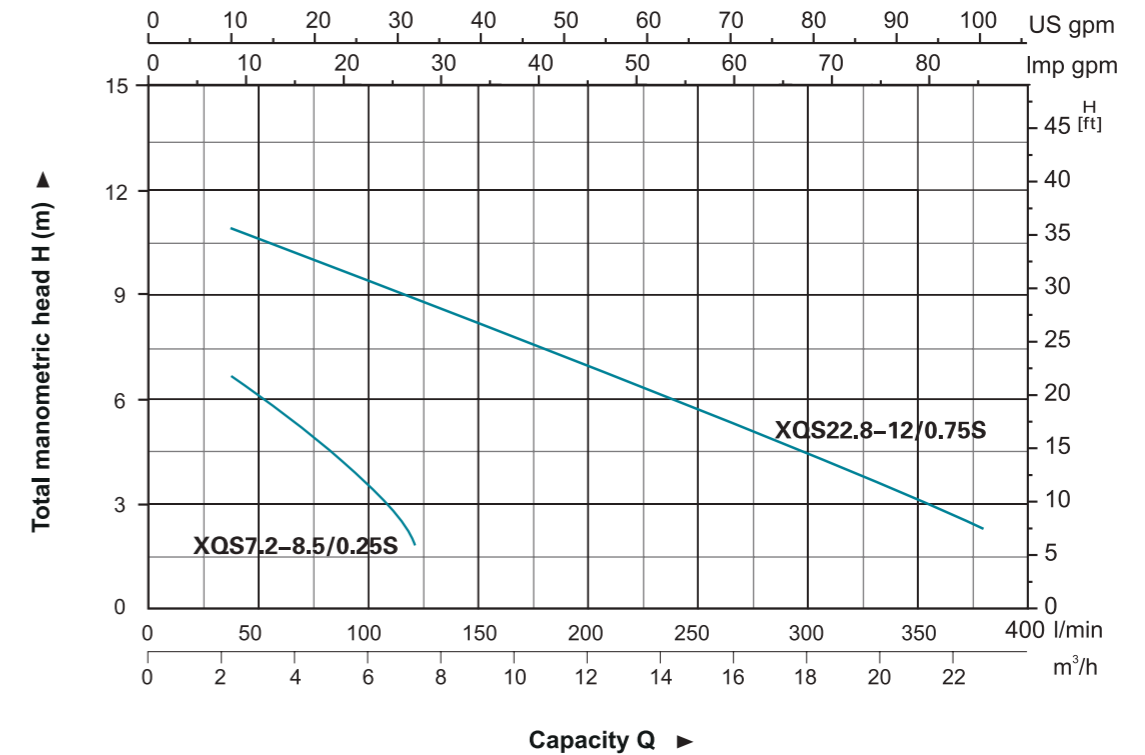

Technical Data

Model	Power		Outlet diameter (mm)	Voltage (V/Hz)	Max. flow (l/min)	Max. head (m)	GW (kgs)	Packing size (mm)	Quantity (PCS/20 TEU)
	(kW)	HP							
XQS7.2-8.5/0.25S	0.25	0.33	40,32,25	220/50	120	8.5	10.2	175x175x360	2131
XQS22.8-12/0.75S	0.75	1.0	50	220/50	380	12	19.2	220x220x440	1132

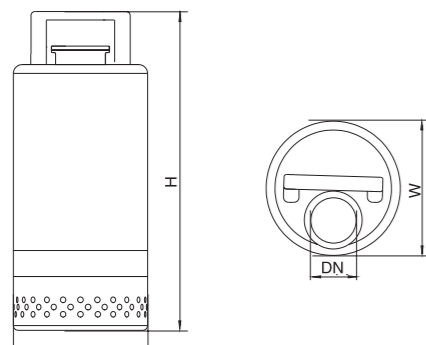

Dimension

Model	DN	L (mm)	W (mm)	H (mm)
XQS7.2-8.5/0.25S	1 1/4"	142	142	300
XQS22.8-12/0.75S	2"	170	170	380

Materials Table

No.	Part	Material	No.	Part	Material
1	Handle	Stainless steel	27	Stretching washer	65Mn
2	Screw	Stainless steel	28	Washer	CuZn40
3	Nut	Stainless steel	29	Motor cover	Stainless steel
4	Protector	FKM	30	Thermal protector	
5	Cable presser	Stainless steel	31	O-ring	FKM
6	Screw	Stainless steel	32	Stator	
7	Flange	Stainless steel	33	Wave washer	65Mn
8	Cable		34	Ball bearing	
9	Cable protector	CR	35	Rotor	
10	Connector	ABS	36	Connection part	Stainless steel
11	O-ring	FKM	37	O-ring	FKM
12	Motor shell	Stainless steel	38	O-ring	FKM
13	Rubber washer	FKM	39	Oil chamber cover	Stainless steel
14	Washer	Steel	40	Mechanical seal	Sic/Sic
15	Stretching washer	Stainless steel	41	O-ring	FKM
16	Washer	Stainless steel	42	Pump body	Stainless steel
17	Screw	Stainless steel	43	Screw	Stainless steel
18	O-ring	FKM	44	Oil seal	
19	Rubber washer	FKM	45	Impeller	Stainless steel
20	Capacitor cover	Stainless steel	46	Screw	Stainless steel
21	Bolt	Stainless steel	47	Nut	Stainless steel
22	Capacitor		48	Rubber washer	FKM
23	Screw	Stainless steel	49	Screw	Stainless steel
24	O-ring	FKM	50	Screw	Stainless steel
25	Cable holder	NBR	51	Filter mesh	Stainless steel
26	Screw	CuZn40			

