



### Application

- Small electrical irrigation and drainage equipments
- Particularly applied in urban well water pumping, field irrigation and drainage, garden irrigation and household water supply, as well as drainage of industrial accumulated water, water supply and drainage for construction, livestock breeding, etc.

### Pump

- Max. immersion depth: 5 m
- Max. liquid temperature: +40°C
- Liquid pH value: 6.5 – 8

### Motor

- Copper winding
- Built-in thermal protector
- Stainless steel welded shaft
- Insulation class: B
- Protection class: IP68

### Identification Codes

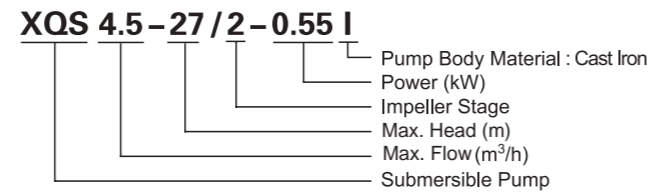

### Hydraulic Performance Curves

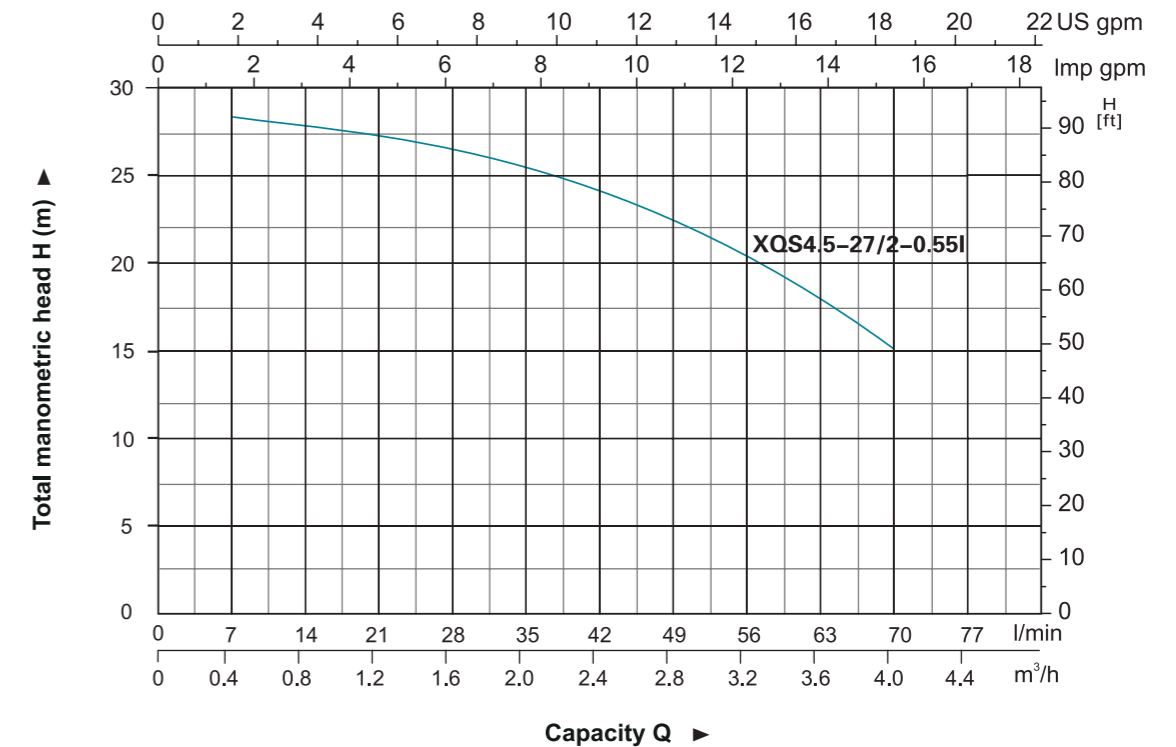

### Technical Data

Model	Power		Outlet diameter (mm)	Voltage (V/Hz)	Max. flow (l/min)	Max. head (m)	GW (kgs)	Packing size (mm)	Quantity (PCS/20 TEU)
	(kW)	HP							
XQS4.5-27/2-0.55I	0.55	0.75	25	220/50	75	27	21.8	500x270x235	980

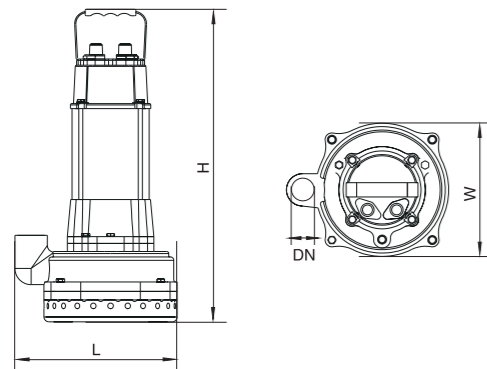

### Dimension

Model	DN	L (mm)	W (mm)	H (mm)
XQS4.5-27/2-0.55I	1"	235	198	462

### Materials Table

No.	Part	Material	No.	Part	Material
1	Bolt	Stainless steel	33	Ball bearing	
2	Stretching washer	Stainless steel	34	Bolt	Stainless steel
3	Washer	Stainless steel	35	Washer	Stainless steel
4	Bolt	Stainless steel	36	Connection part	HT200
5	Washer	Stainless steel	37	Mechanical seal	Carbon/Ceramic
6	Handle	Stainless steel	38	O-ring	NBR
7	Nut	Stainless steel	39	Oil chamber cover	HT200
8	Protector	NR	40	Screw	Stainless steel
9	Cable presser	Stainless steel	41	Washer	Stainless steel
10	Washer	Stainless steel	42	O-ring	Stainless steel
11	Screw	Stainless steel	43	Screw	Stainless steel
12	Bolt	Stainless steel	44	Bolt	Stainless steel
13	O-ring	NBR	45	Washer	Stainless steel
14	Bolt	Stainless steel	46	Connector	ABS
15	Flange	Stainless steel	47	O-ring	NBR
16	Cable		48	Pump body	HT200
17	Cable protector	CR	49	Mechanical seal	Carbon/Ceramic
18	Capacitor cover	HT200	50	Impeller	PPO
19	Capacitor		51	Guidleaf cover	PPO
20	O-ring	NBR	52	Guidleaf	PPO
21	O-ring	NBR	53	Sleeve	PPO
22	Screw	CuZu40	54	O-ring	NBR
23	Stretching washer	65Mn	55	Washer	Stainless steel
24	Washer	CuZu40	56	Stretching washer	Stainless steel
25	Cable holder	NBR	57	Nut	Stainless steel
26	Motor cover	HT200	58	O-ring	NBR
27	Thermal protector		59	Pump cover	HT200
28	Stator		60	Nut	
29	O-ring	NBR	61	Bilateral bolt	Stainless steel
30	Wave washer	65Mn	62	Filter mesh	Stainless steel
31	Ball bearing		63	Float switch	
32	Rotor				

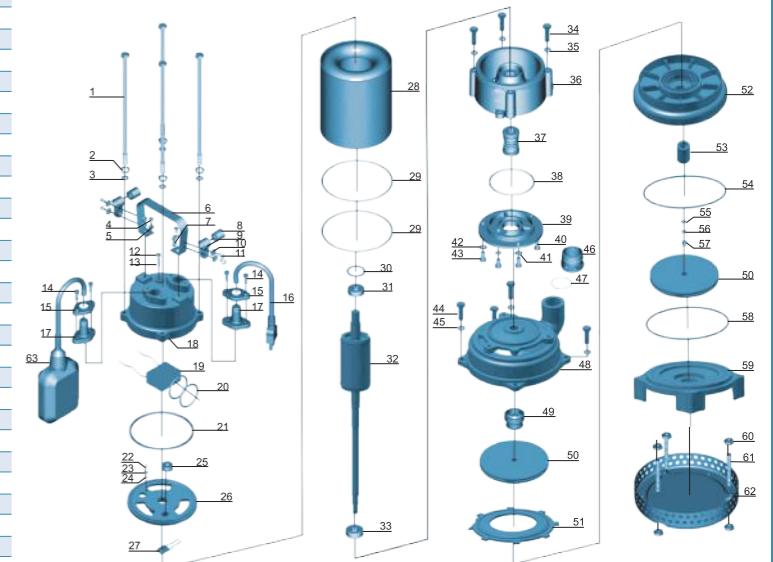



### Application

- Small electrical irrigation and drainage equipments
- Particularly applied in urban well water pumping, field irrigation and drainage, garden irrigation and household water supply, as well as drainage of industrial accumulated water, water supply and drainage for construction, livestock breeding, etc.

### Pump

- Max. immersion depth: 5 m
- Max. liquid temperature: +40°C
- Liquid pH value: 6.5 – 8

### Motor

- Copper winding
- Built-in thermal protector
- Stainless steel welded shaft
- Insulation class: B
- Protection class: IP68

### Identification Codes

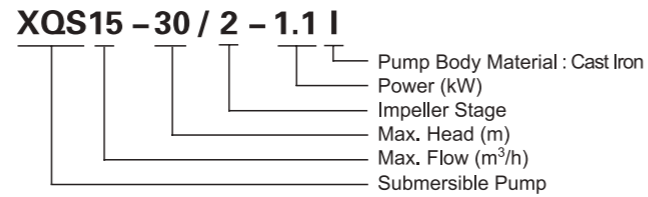

### Hydraulic Performance Curves

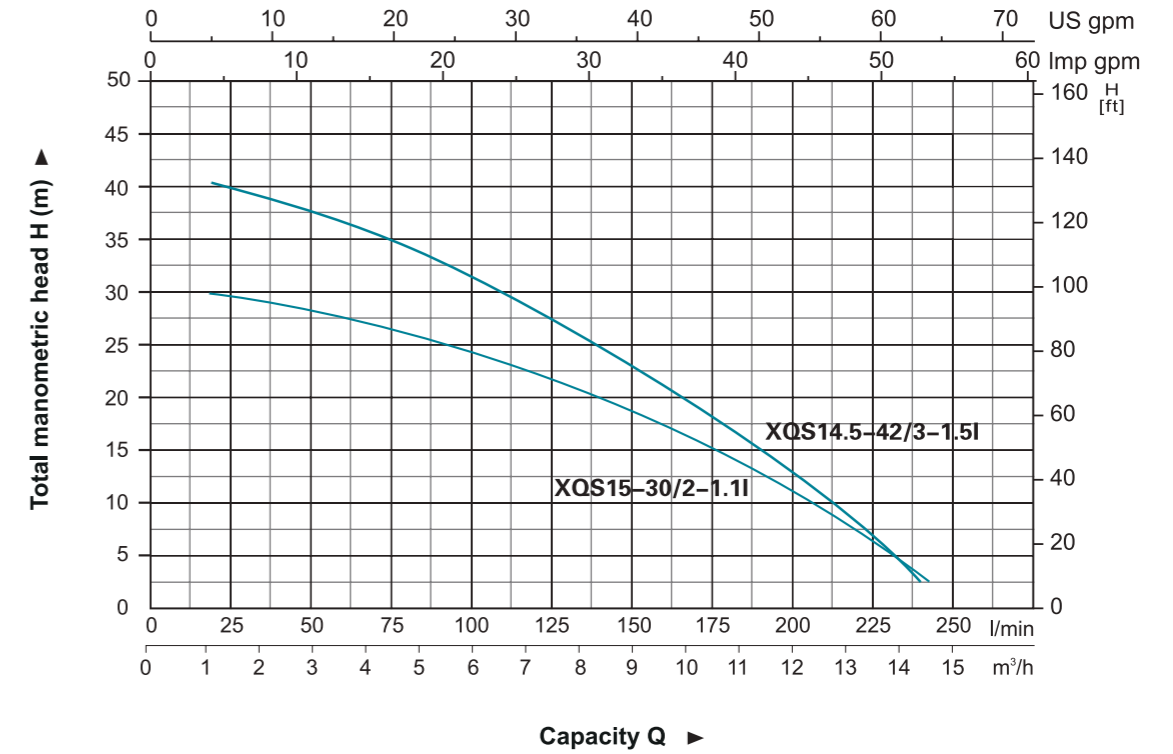

### Technical Data

Model	Power		Outlet diameter (mm)	Voltage (V/Hz)	Max. flow (l/min)	Max. head (m)	GW (kgs)	Packing size (mm)	Quantity (PCS/20' TEU)
	(kW)	HP							
XQS15-30/2-1.1I	1.1	1.5	50	220/50	250	30	23.3	555x290x220	840
XQS14.5-42/3-1.5I	1.5	2.0	50	220/50	240	42	26.8	625x285x205	814

### Materials Table

No.	Part	Material	No.	Part	Material
1	Bolt	Stainless steel	29	Stator	
2	Stretching washer	Stainless steel	30	Wave washer	65Mn
3	Washer	Stainless steel	31	Ball bearing	
4	Bolt	Stainless steel	32	Rotor	
5	Washer	Stainless steel	33	Ball bearing	
6	Handle	Stainless steel	34	Connection part	HT200
7	Nut	Stainless steel	35	Mechanical seal	Carbon/Ceramic
8	Protector	NR	36	O-ring	NBR
9	Cable presser	Stainless steel	37	Connector	ABS
10	Washer	Stainless steel	38	O-ring	NBR
11	Screw	Stainless steel	39	Pump body	HT200
12	Bolt	Stainless steel	40	Screw	Stainless steel
13	O-ring	NBR	41	Oil seal	
14	Screw	Stainless steel	42	Rubber washer	NBR
15	Flange	Stainless steel	43	Impeller	HT200
16	Cable		44	Ring	Steel
17	Cable protector	CR	45	O-ring	NBR
18	Capacitor cover	HT200	46	Diffuser	HT200
19	Capacitor		47	Stretching washer	Stainless steel
20	O-ring	NBR	48	Screw	Stainless steel
21	Rubber washer	NBR	49	Nut	Stainless steel
22	Screw	CuZn40	50	Pump cover	HT200
23	Stretching washer	65Mn	51	Washer	Stainless steel
24	Washer	CuZn40	52	Screw	Stainless steel
25	Cable holder	NBR	53	Filter mesh	Steel
26	Motor cover	HT200	54	Float switch	
27	Thermal protector		55	Key	Steel
28	O-ring	NBR			

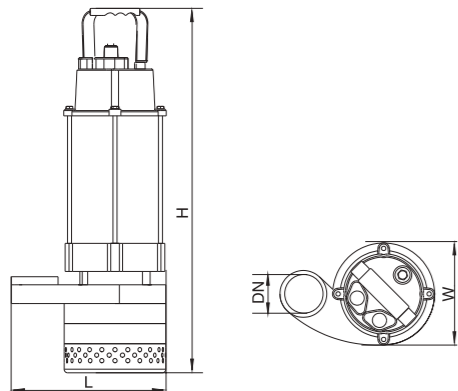
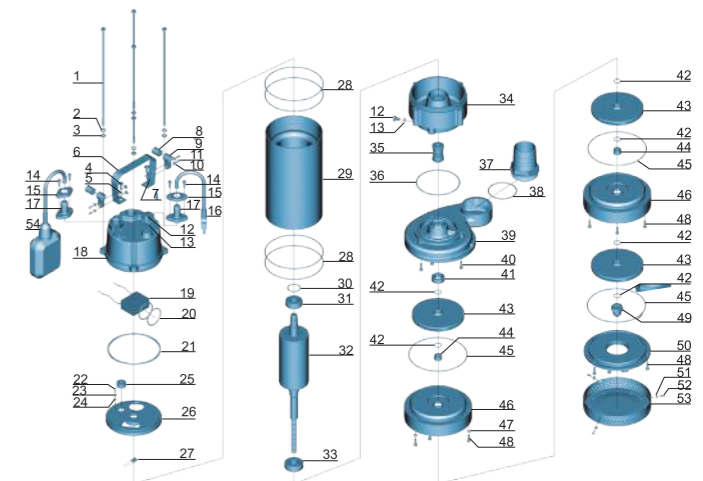

### Dimension

Model	DN	L (mm)	W (mm)	H (mm)
XQS15-30/2-1.1I	2"	232	152	508
XQS14.5-42/3-1.5I		232	152	567



## Application

- Small electrical irrigation and drainage equipments
- Particularly applied in urban well water pumping, field irrigation and drainage, garden irrigation and household water supply, as well as drainage of industrial accumulated water, water supply and drainage for construction, livestock breeding, etc.

## Pump

- Max. immersion depth: 5 m
- Max. liquid temperature: +40°C
- Liquid pH value: 6.5 – 8

## Motor

- Copper winding
- Built-in thermal protector
- Stainless steel welded shaft
- Insulation class: B
- Protection class: IP68

## Identification Codes

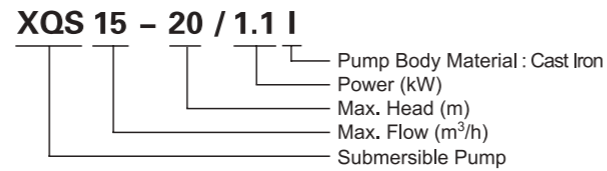

## Hydraulic Performance Curves

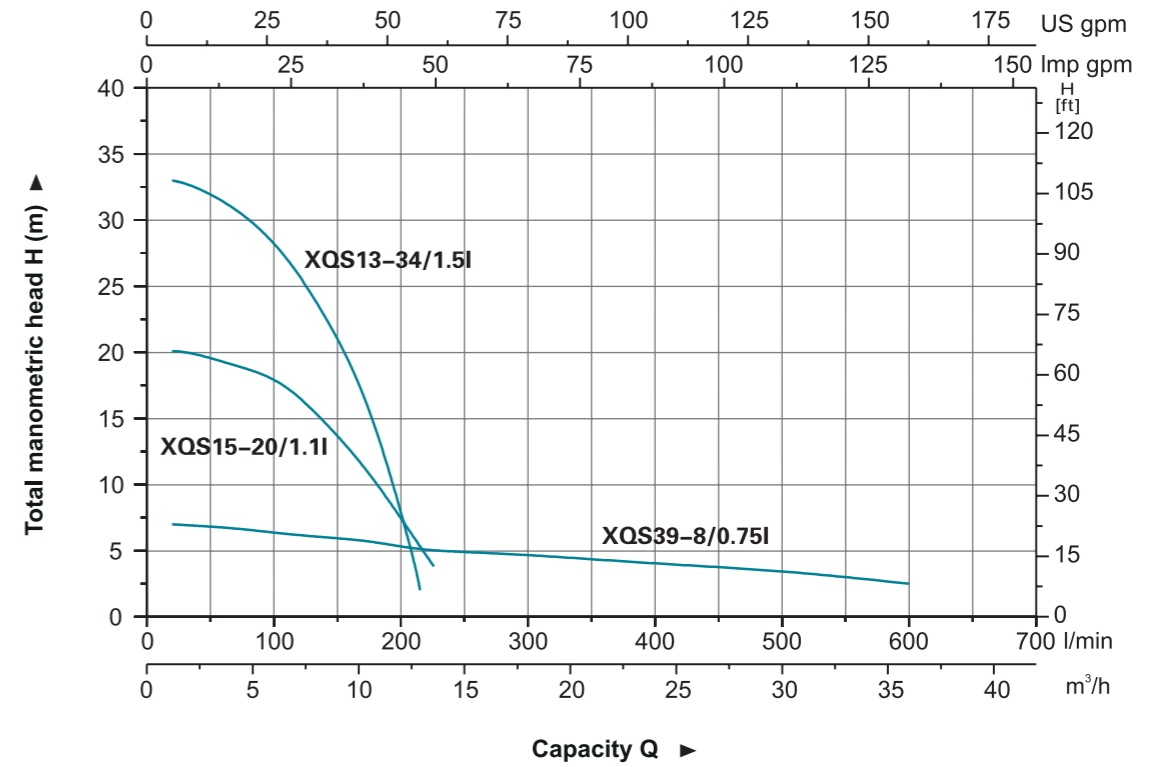

## Technical Data

Model	Power		Outlet diameter (mm)	Voltage (V/Hz)	Max. flow (l/min)	Max. head (m)	GW (kgs)	Packing size (mm)	Quantity (PCS/20 TEU)
	(kW)	HP							
XQS39-8/0.75I	0.75	1.0	75	220/50	650	8	21.6	580x320x250	684
XQS15-20/1.1I	1.1	1.5	40,32,25	220/50	250	20	21.5	510x290x220	880
XQS13-34/1.5I	1.5	2.0	40,32,25	220/50	216	34	25.3	580x320x250	648

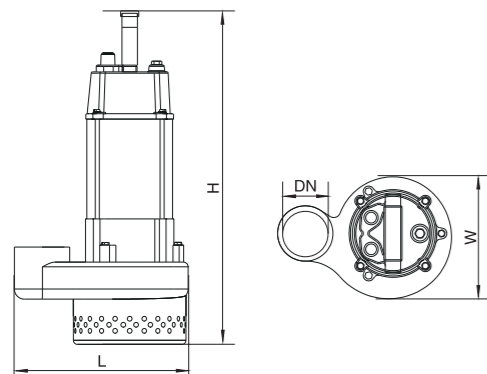

## Dimension

Model	DN	L (mm)	W (mm)	H (mm)
XQS39-8/0.75I	2 1/2"	207	109	500
XQS15-20/1.1I	1 1/4"	238	177	460
XQS13-34/1.5I		250	205	512

## Materials Table

No.	Part	Material	No.	Part	Material
1	Bolt	Stainless steel	26	Thermal protector	
2	Stretching washer	Stainless steel	27	O-ring	NBR
3	Washer	Stainless steel	28	Stator	
4	Bolt	Stainless steel	29	Wave washer	65Mn
5	Washer	Stainless steel	30	Ball bearing	
6	Handle	Stainless steel	31	Rotor	
7	Nut	Stainless steel	32	Ball bearing	
8	Protector	NR	33	Lower cover	HT200
9	Cable presser	Stainless steel	34	Oil seal	
10	Washer	Stainless steel	35	Connector	ABS
11	Screw	Stainless steel	36	O-ring	NBR
12	Bolt	Stainless steel	37	Pump body	HT200
13	O-ring	NBR	38	Mechanical seal	Carbon/Ceramic
14	Screw	Stainless steel	39	Impeller	HT200
15	Flange	Stainless steel	40	Nut	Stainless steel
16	Cable		41	O-ring	NBR
17	Cable protector	CR	42	Pump body	HT200
18	Capacitor cover	HT200	43	Washer	Stainless steel
19	Capacitor		44	Screw	Stainless steel
20	O-ring	NBR	45	Filter mesh	Steel
21	Cable holder	NBR	46	Washer	Stainless steel
22	Screw	CuZn40	47	Screw	Stainless steel
23	Stretching washer	65Mn	48	Stretching washer	Stainless steel
24	Washer	CuZn40	49	Float switch	
25	Upper cover	HT200			

