

الکتروپمپ خطی سه فاز PENTAX سری PIL40 , PIL50



PIL	تعداد دور		POWER		Hmax (m)	Qmax (m ³ /h)	ورودی - خروجی			
	POLE	(rpm)	KW	HP			Inch	(mm)		
PIL 40-125/05-IR	4	1500	0.55	0.75	8.1	17.5	1½"	40		
PIL 40-125/11-IR	2	3000	1.1	1.5	18	26				
PIL 40-125/15-IR	2	3000	1.5	2	23	29				
PIL 40-125/22-IR	2	3000	2.2	3	27	34				
PIL 40-125/30-IR	2	3000	3	4	31.9	38				
PIL 40-160/05-IR	4	1500	0.55	0.75	10.1	17.8				
PIL 40-160/07-IR	4	1500	0.75	1	12.1	21				
PIL 40-160/22-IR	2	3000	2.2	3	25	33.5				
PIL 40-160/40-IR	2	3000	4	5.5	33.5	45				
PIL 40-160/55-IR	2	3000	5.5	7.5	40	52				
PIL 40-200/07-IR	4	1500	0.75	1	11.2	13.9				
PIL 40-200/11-IR	4	1500	1.1	1.5	13.8	16.8				
PIL 40-200/55-IR	2	3000	5.5	7.5	55.8	26				
PIL 40-200/75-IR	2	3000	7.5	10	64	30				
PIL 40-250/11-IR	4	1500	1.1	1.5	16	14				
PIL 40-250/15-IR	4	1500	1.5	2	19	16.8				
PIL 40-250/22-IR	4	1500	2.2	3	22.3	19.7				
PIL 40-250/30-IR	4	1500	3	4	25	22.4				
PIL 50-125/05-IR	4	1500	0.55	0.75	8.2	25.3			2"	50
PIL 50-125/30-IR	2	3000	3	4	28	42.5				
PIL 50-125/40-IR	2	3000	4	5.5	33	50				
PIL 50-160/05-IR	4	1500	0.55	0.75	9.8	24.1				
PIL 50-160/07-IR	4	1500	0.75	1	11.3	28.1				
PIL 50-160/11-IR	4	1500	1.1	1.5	12.5	31				
PIL 50-160/30-IR	2	3000	3	4	28.7	47				
PIL 50-160/40-IR	2	3000	4	5.5	33	55				
PIL 50-160/55-IR	2	3000	5.5	7.5	40.8	67				
PIL 50-200/07-IR	4	1500	0.75	1	10.2	24				
PIL 50-200/11-IR	4	1500	1.1	1.5	12.8	29				
PIL 50-200/15-IR	4	1500	1.5	2	14.8	34				
PIL 50-200/22-IR	4	1500	2.2	3	15.8	36.5				
PIL 50-200/40-IR	2	3000	4	5.5	42	36				
PIL 50-200/55-IR	2	3000	5.5	7.5	49	42				
PIL 50-200/75-IR	2	3000	7.5	10	56	48				
PIL 50-200/110-IR	2	3000	11	15	68	58				
PIL 50-250/15-IR	4	1500	1.5	2	18.9	24				
PIL 50-250/22-IR	4	1500	2.2	3	22.5	28.8				
PIL 50-250/30-IR	4	1500	3	4	25.5	32.5				

الکتروپمپ خطی سه فاز PENTAX سری PIL100 , PIL80 , PIL65



PIL	تعداد دور		POWER		Hmax (m)	Qmax (m³/h)	ورودی - خروجی	
	POLE	(rpm)	KW	HP			inch	(mm)
PIL 65-125/05-IR	4	1500	0.55	0.75	7.6	33	2.½"	65
PIL 65-125/07-IR	4	1500	0.75	1	8.6	37.5		
PIL 65-125/22-IR	2	3000	2.2	3	20	52		
PIL 65-125/55-IR	2	3000	5.5	7.5	28.5	74		
PIL 65-160/11-IR	4	1500	1.1	1.5	8.8	57		
PIL 65-160/15-IR	4	1500	1.5	2	10.1	65		
PIL 65-160/40-IR	2	3000	4	5.5	28	63		
PIL 65-160/75-IR	2	3000	7.5	10	37.5	86		
PIL 65-200/15-IR	4	1500	1.5	2	13	53		
PIL 65-200/22-IR	4	1500	2.2	3	14.8	61		
PIL 65-250/22-IR	4	1500	2.2	3	18	43		
PIL 65-250/30-IR	4	1500	3	4	21	49		
PIL 65-250/40-IR	4	1500	4	5.5	25	58		
PIL 80-160/11-IR	4	1500	1.1	1.5	8.1	68	3"	80
PIL 80-160/15-IR	4	1500	1.5	2	9.1	77		
PIL 80-160/22-IR	4	1500	2.2	3	10.7	89		
PIL 80-160/55-IR	2	3000	5.5	7.5	24	90		
PIL 80-160/75-IR	2	3000	7.5	10	28.1	105		
PIL 80-200/30-IR	4	1500	3	4	16.3	80		
PIL 80-200/40-IR	4	1500	4	5.5	18.2	90		
PIL 80-250/40-IR	4	1500	4	5.5	18	63		
PIL 80-250/55-IR	4	1500	5.5	7.5	21.5	73		
PIL 80-250/75-IR	4	1500	7.5	10	23.5	82		
PIL 100-160/15-IR	4	1500	1.5	2	7.3	85	4	100
PIL 100-160/30-IR	4	1500	3	4	9.7	113		
PIL 100-200/40-IR	4	1500	4	5.5	12.9	120		
PIL 100-200/55-IR	4	1500	5.5	7.5	15.2	140		
PIL 100-250/75-IR	4	1500	7.5	10	20	143		

PIL4 SERIES HYDRAULIC PERFORMANCE CURVES

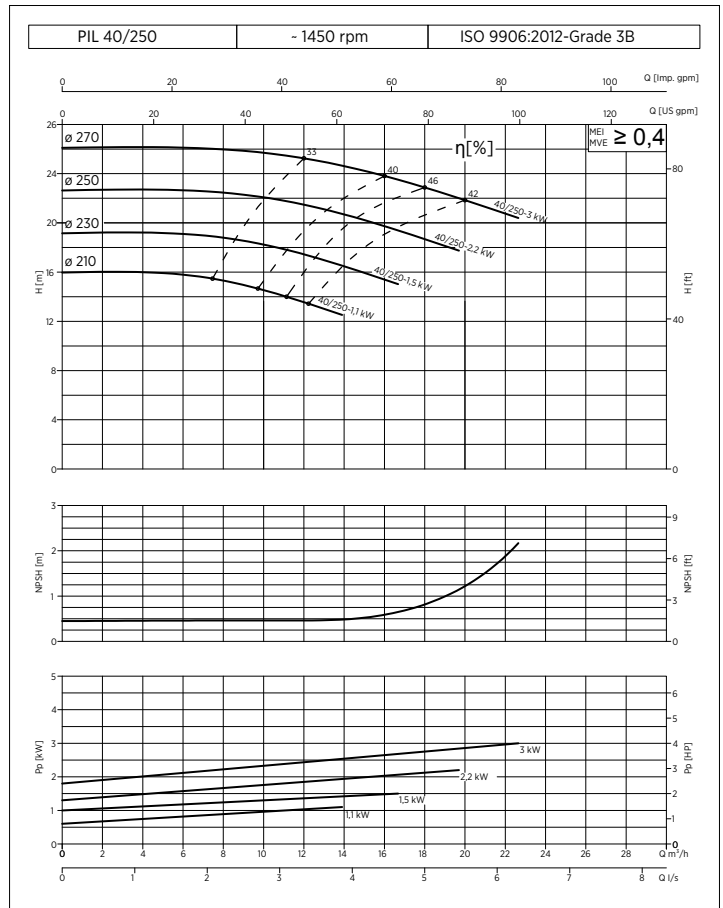
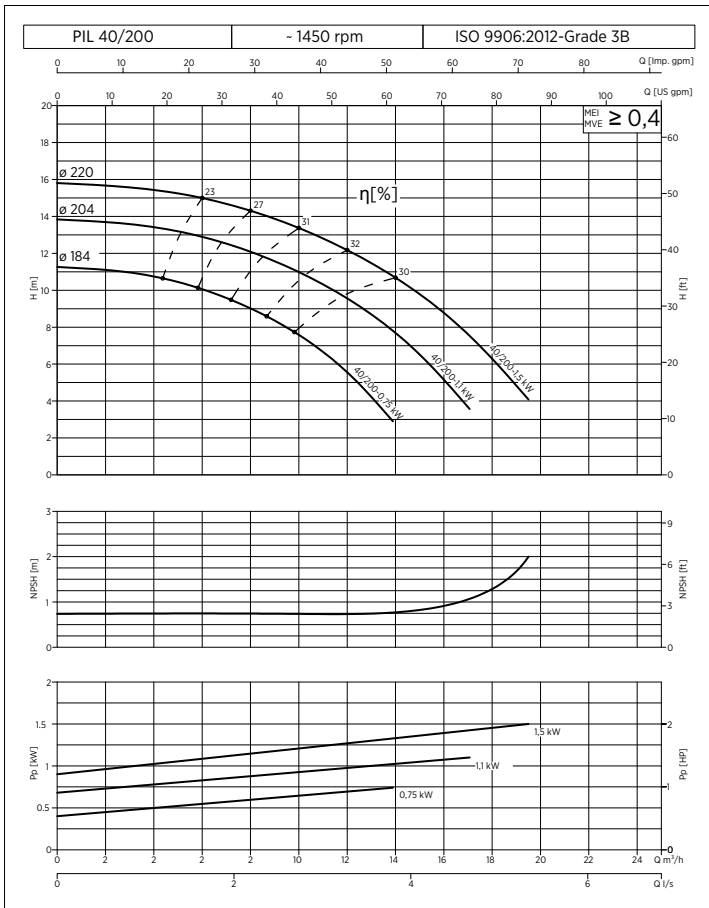
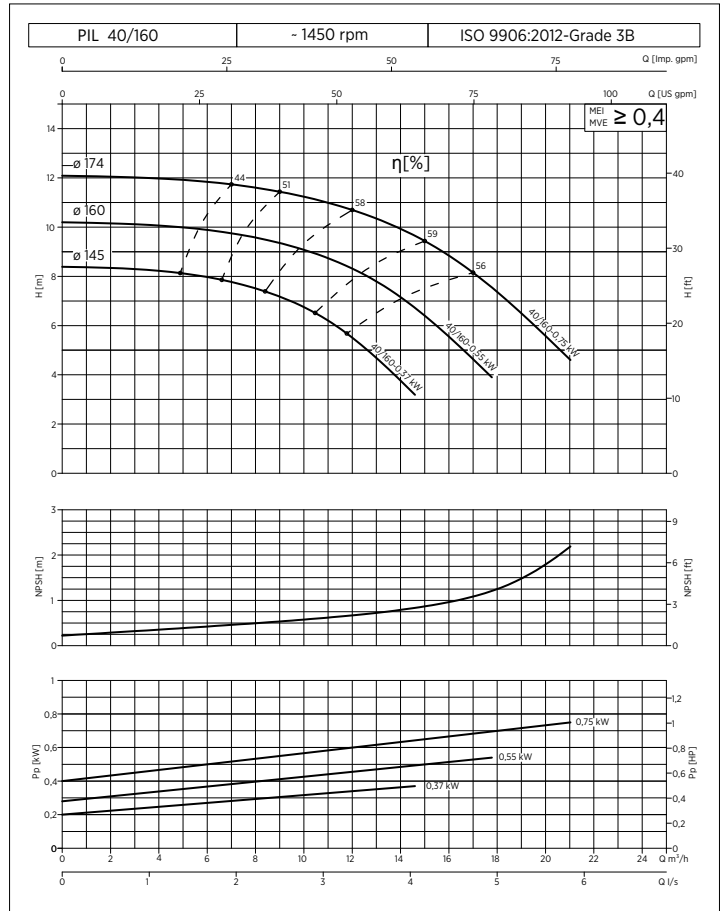
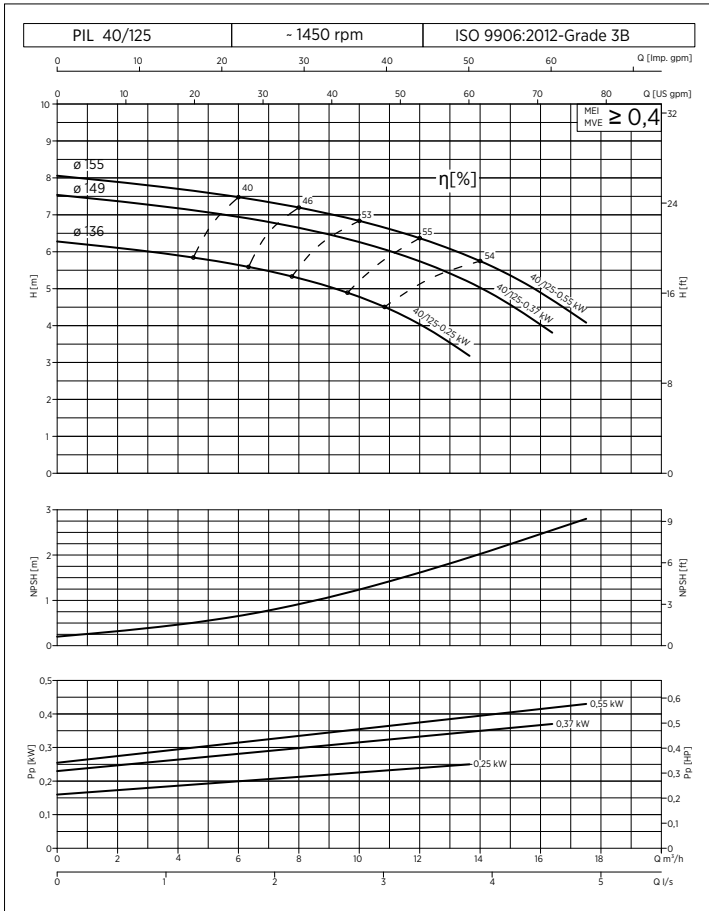

PIL 4 SERIES HYDRAULIC PERFORMANCE CURVES

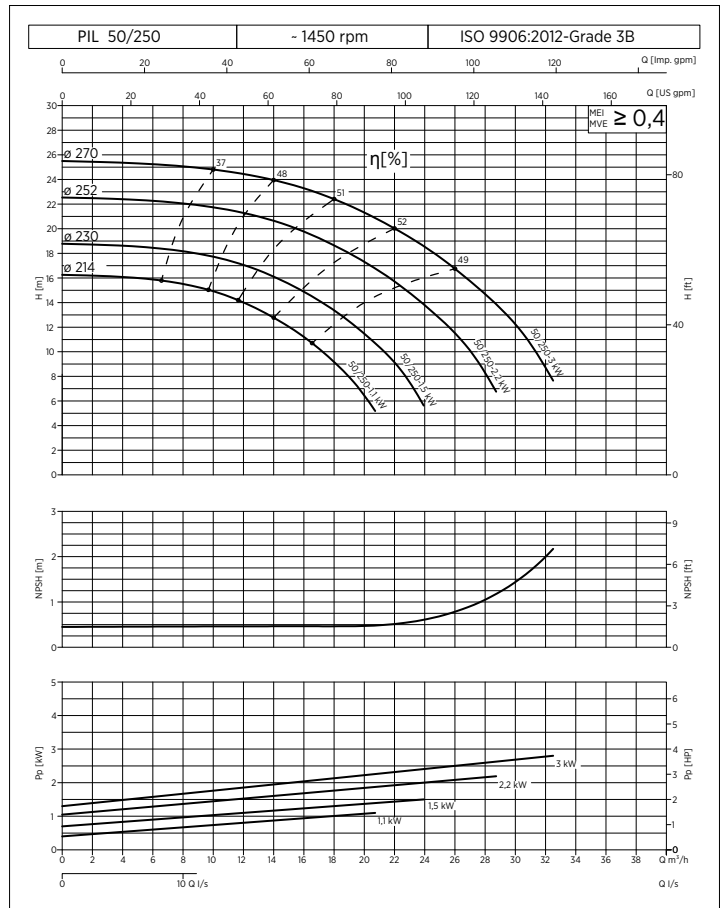
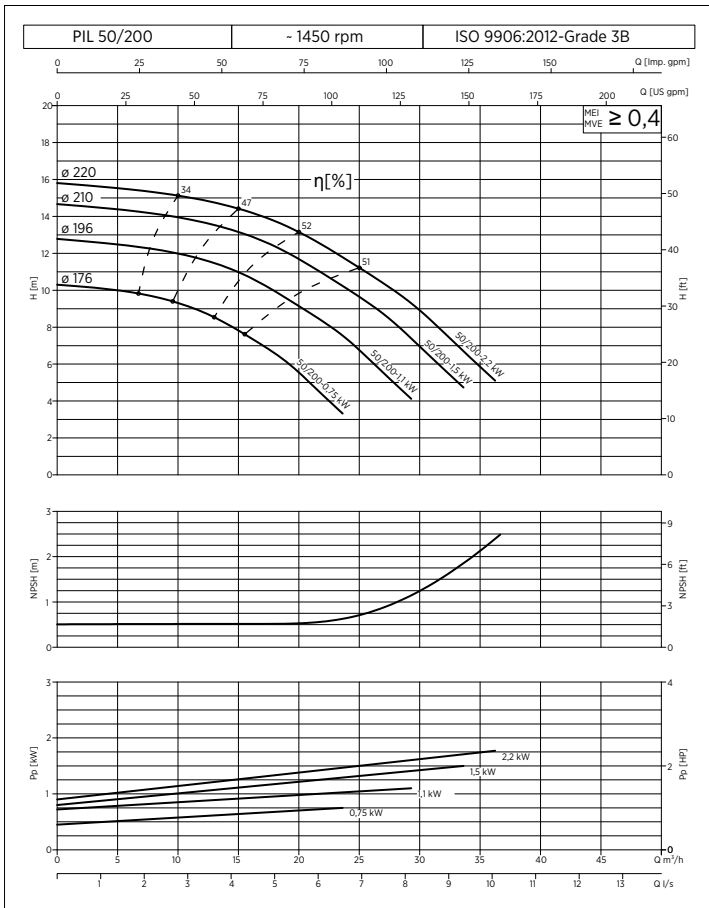
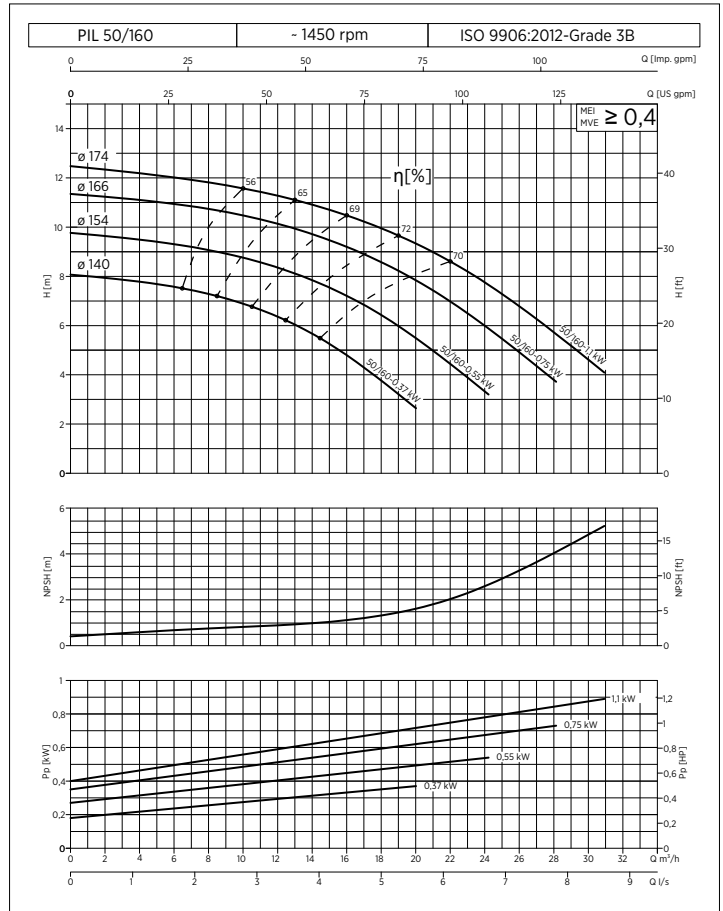
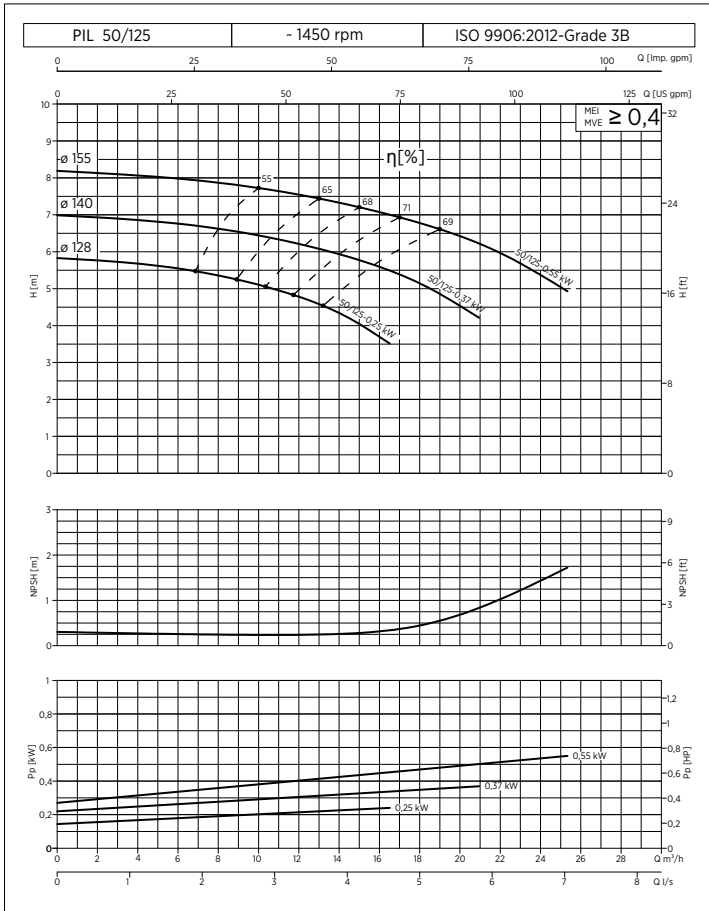

PIL 4 SERIES HYDRAULIC PERFORMANCE CURVES

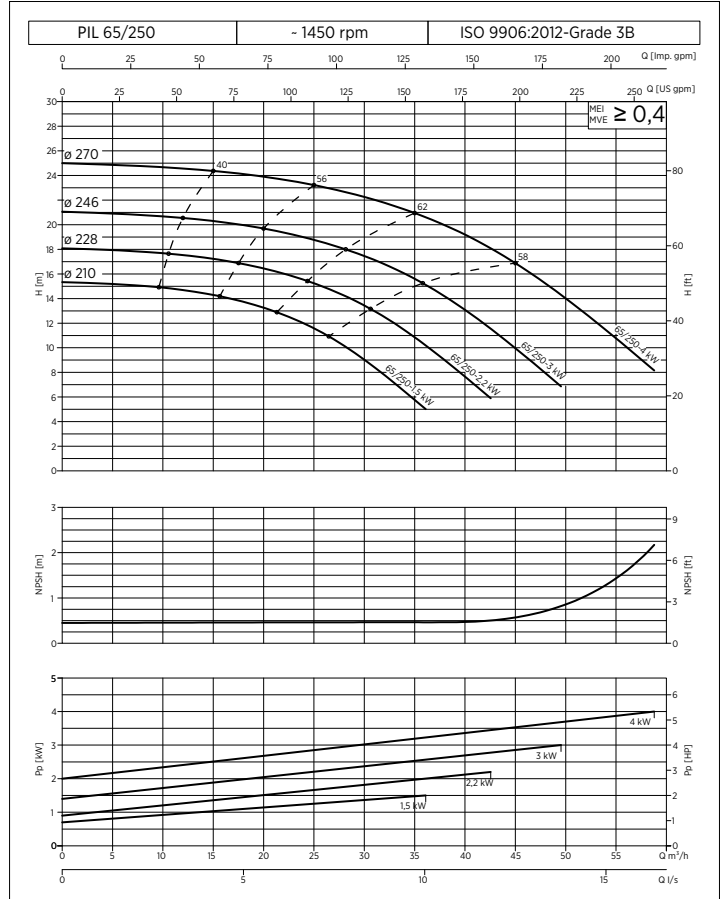
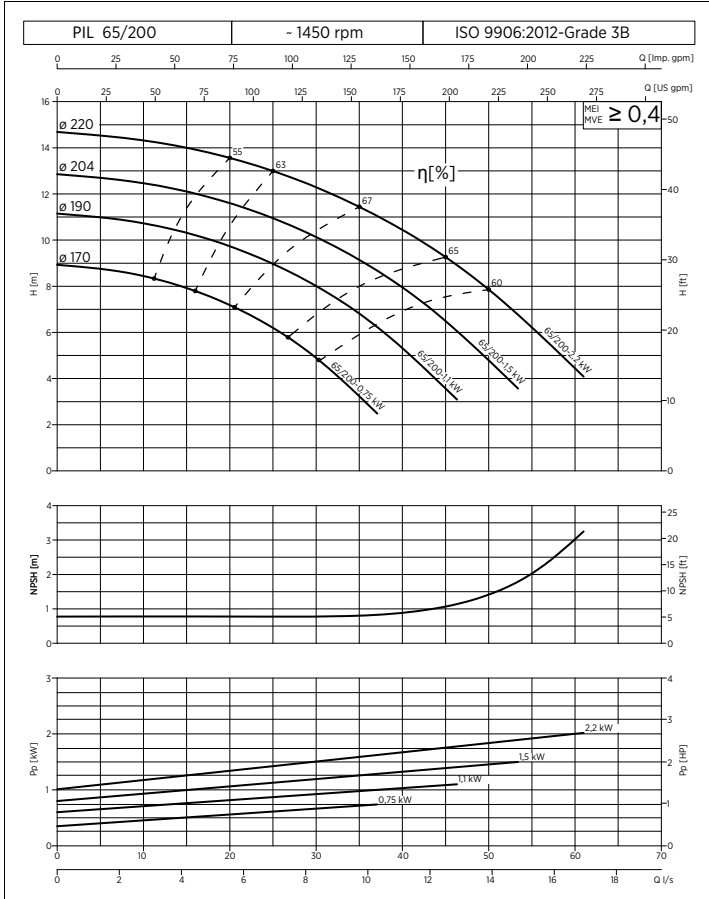
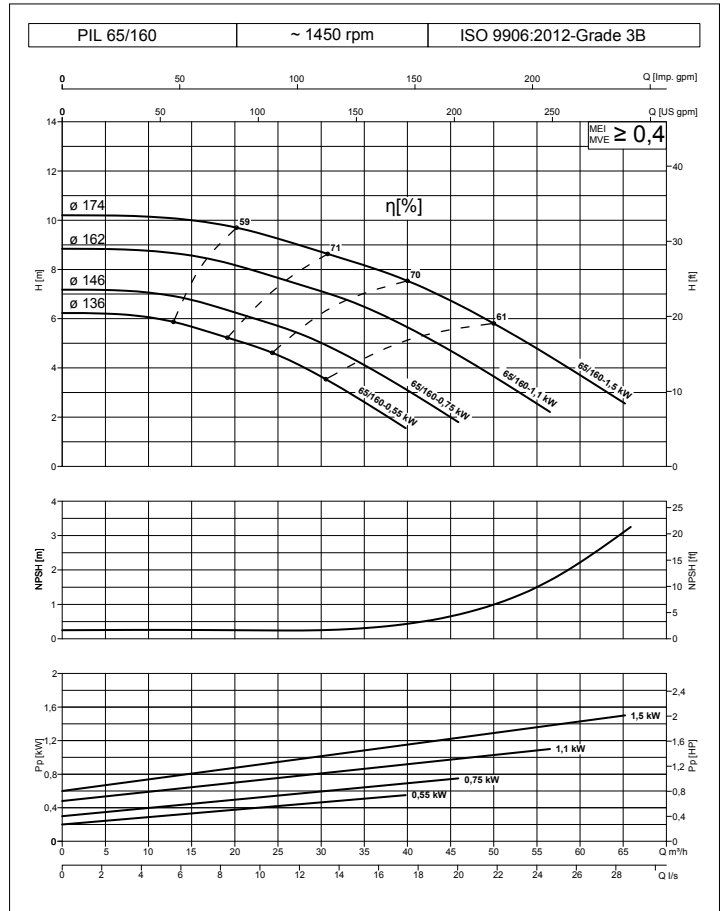
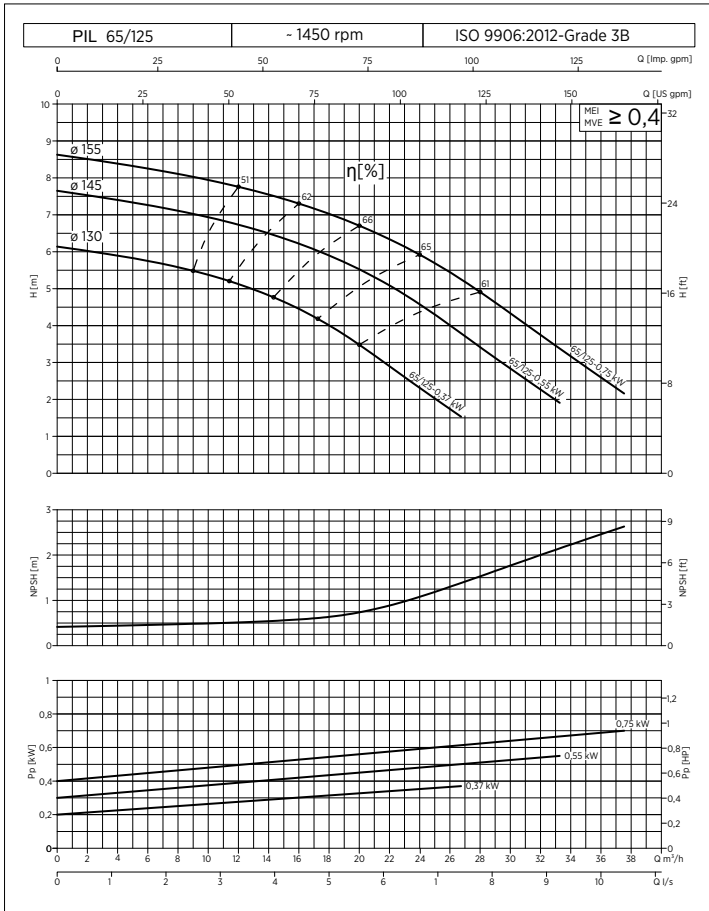

PIL4 SERIES HYDRAULIC PERFORMANCE CURVES

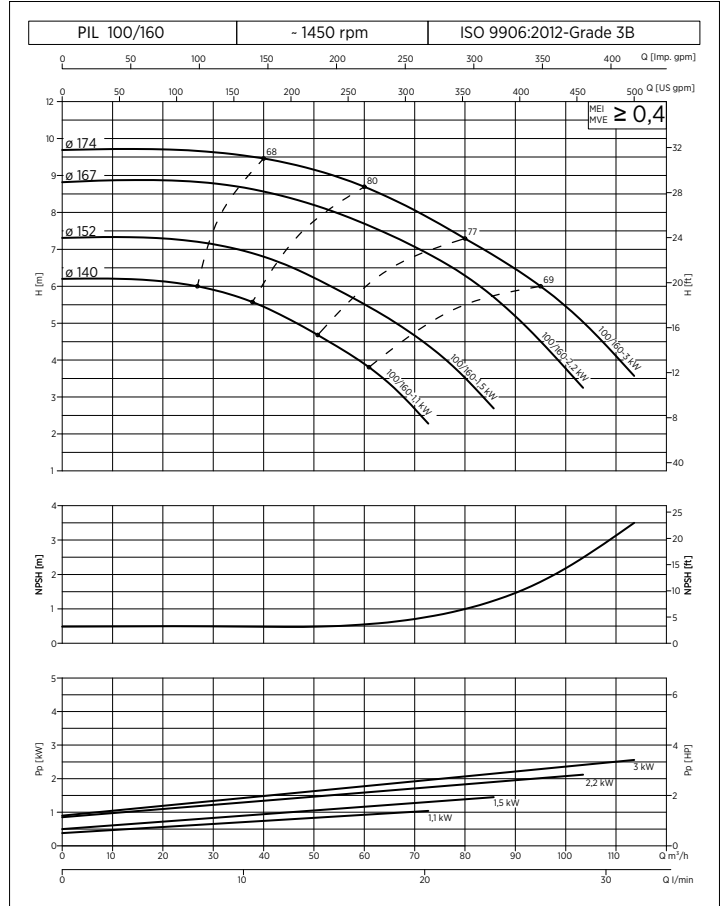
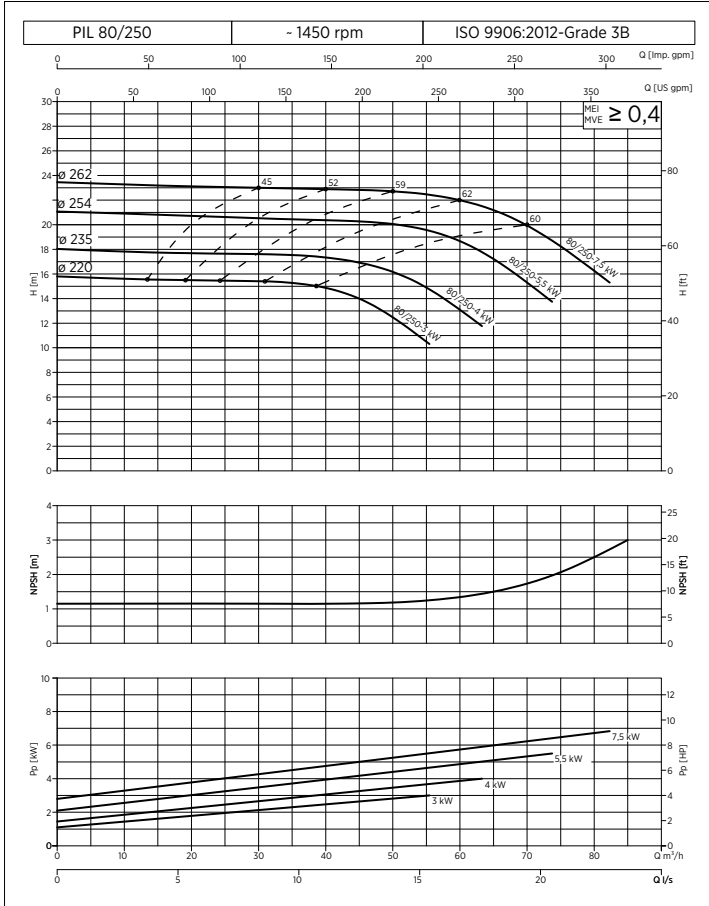
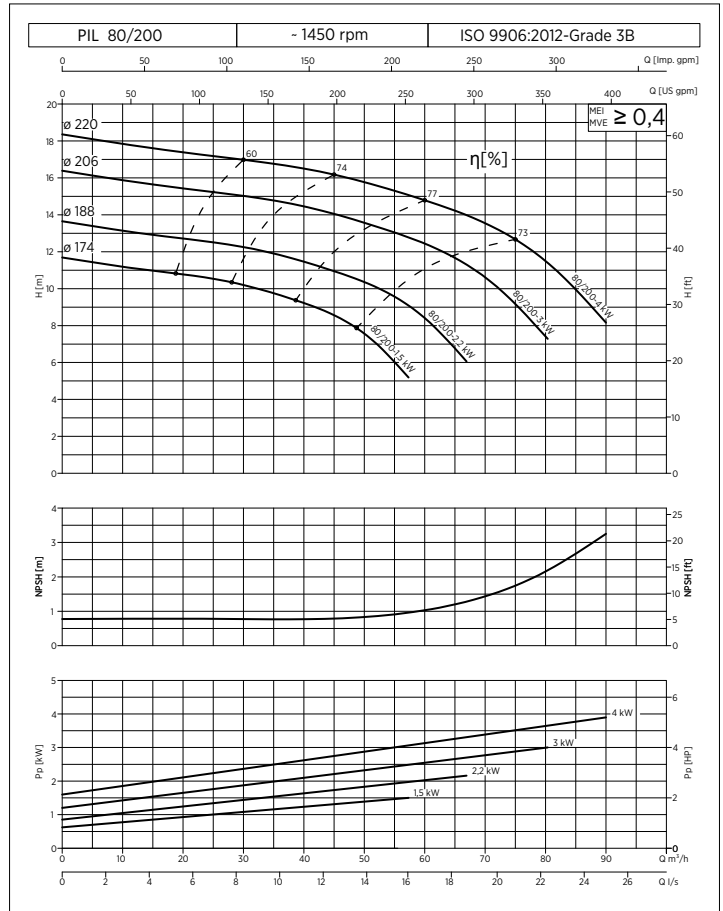
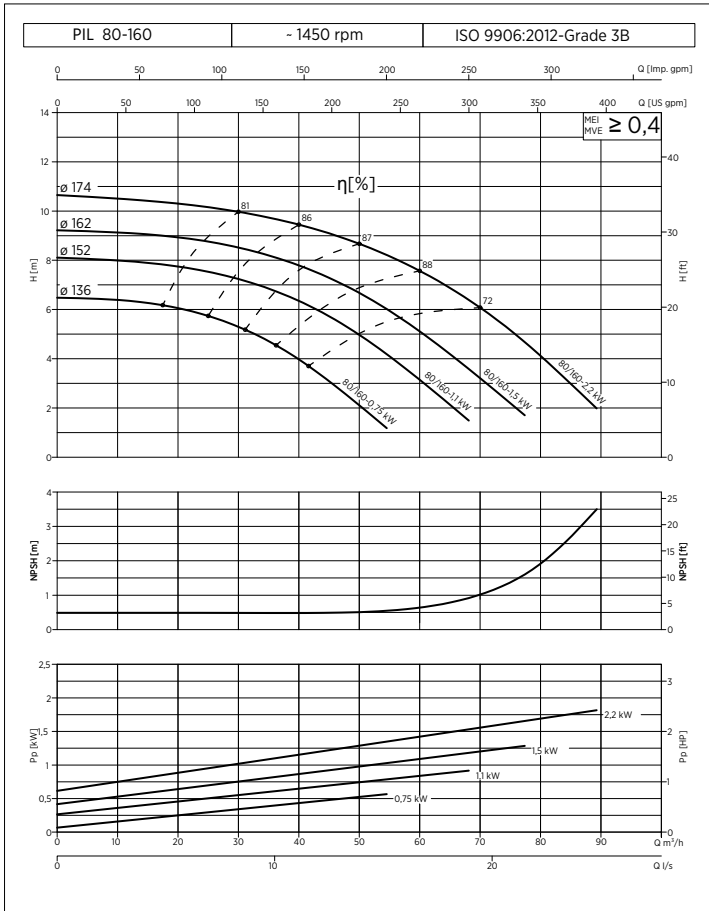

PIL4 SERIES HYDRAULIC PERFORMANCE CURVES

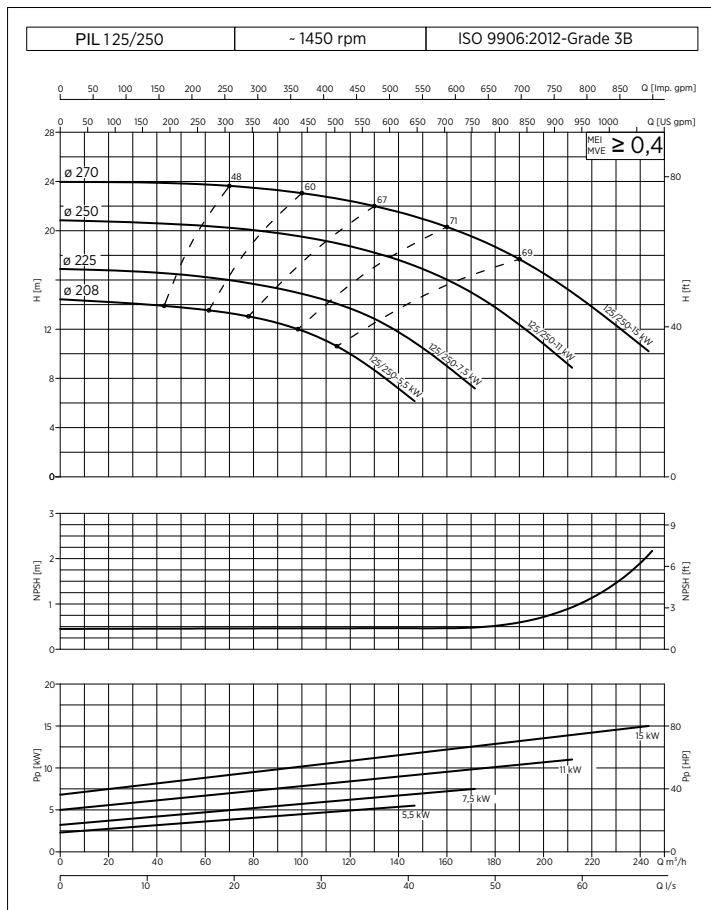
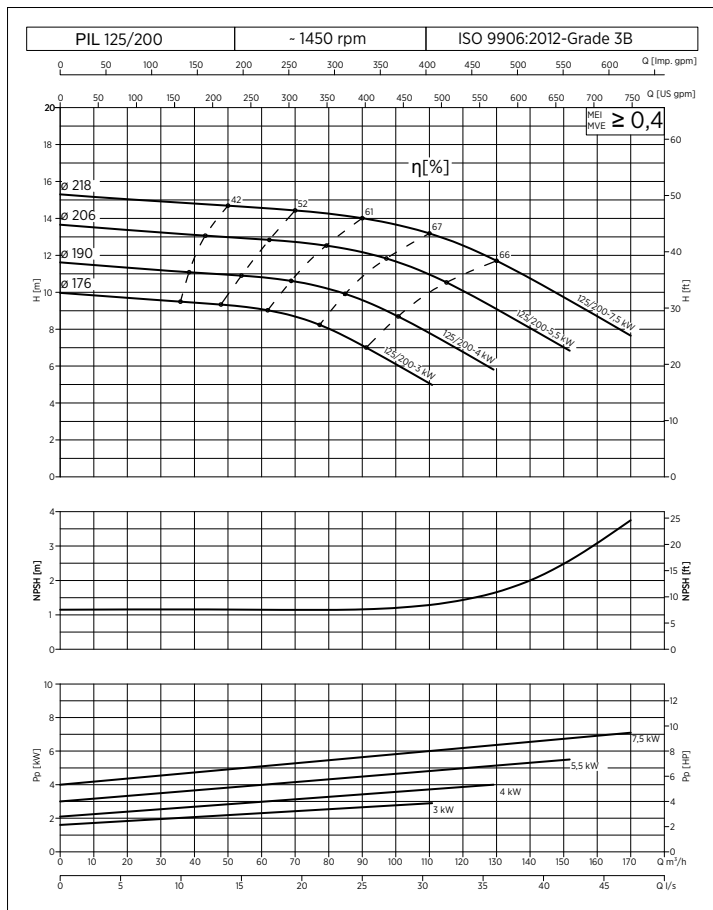
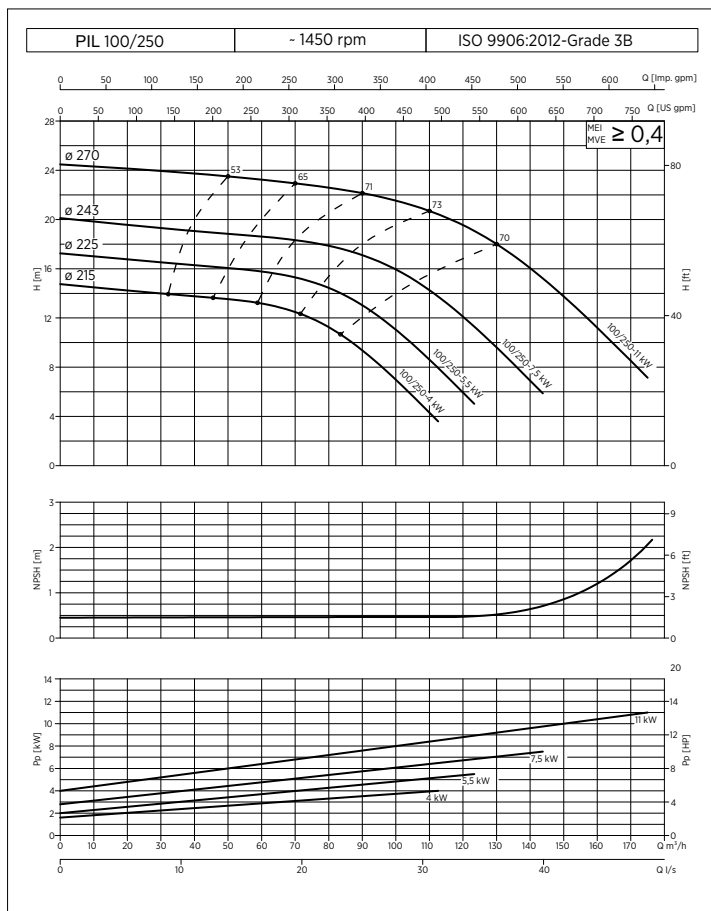
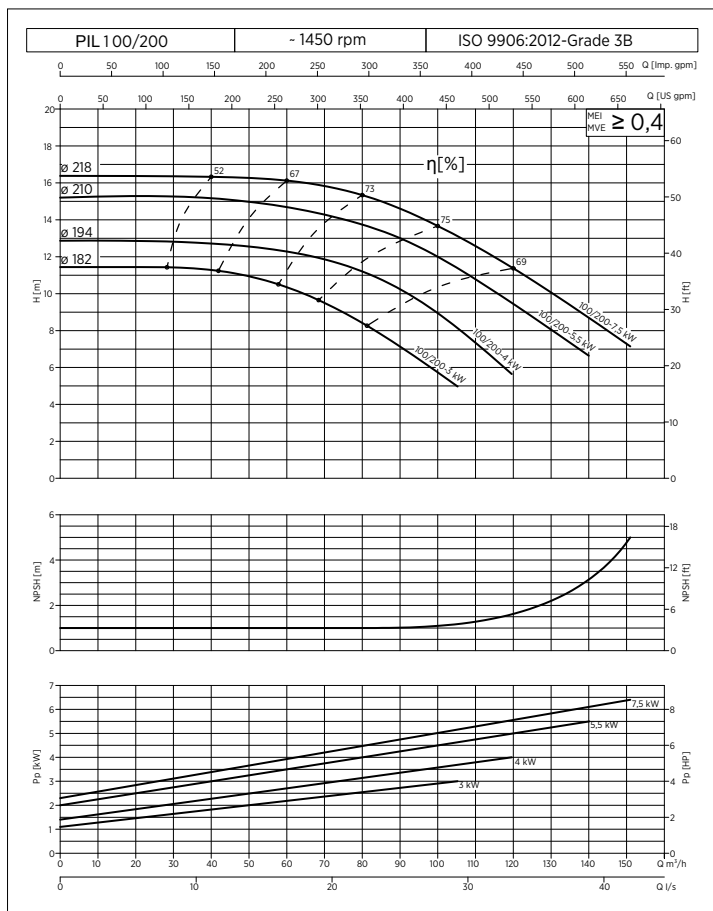

PIL SERIES HYDRAULIC PERFORMANCE CURVES

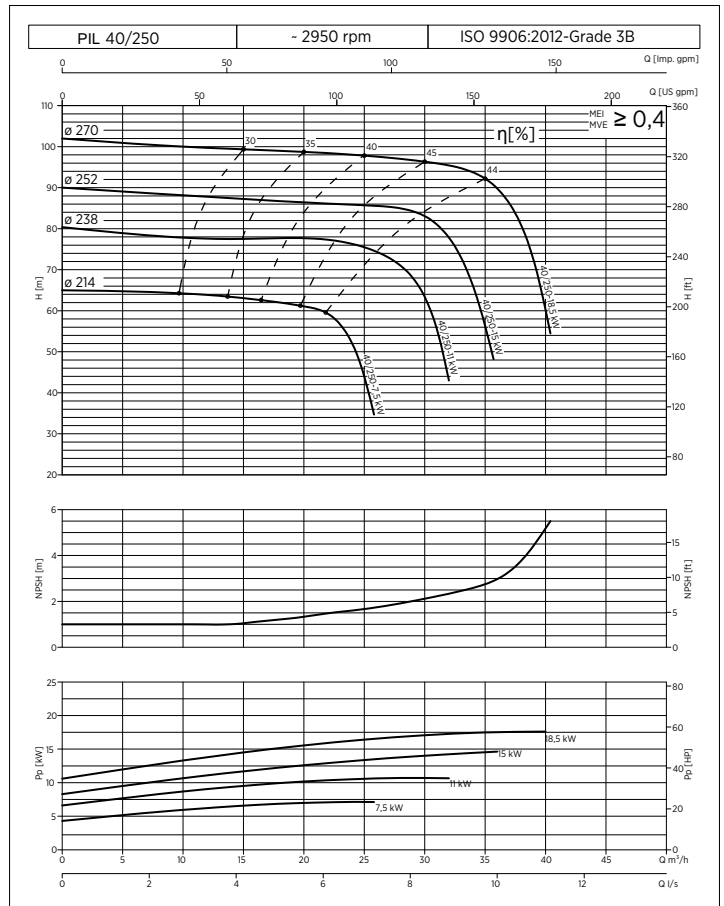
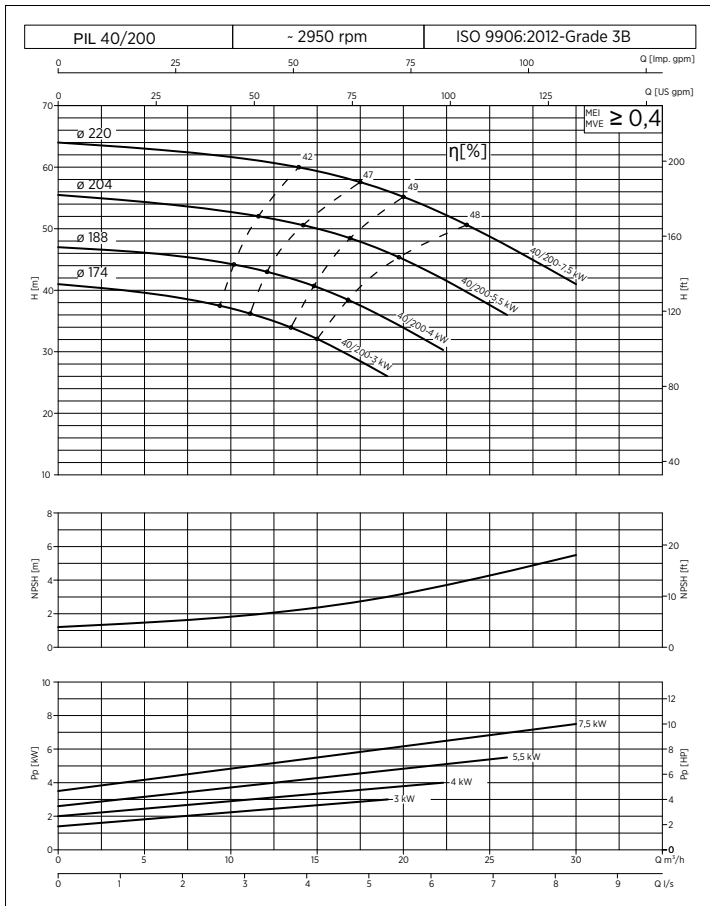
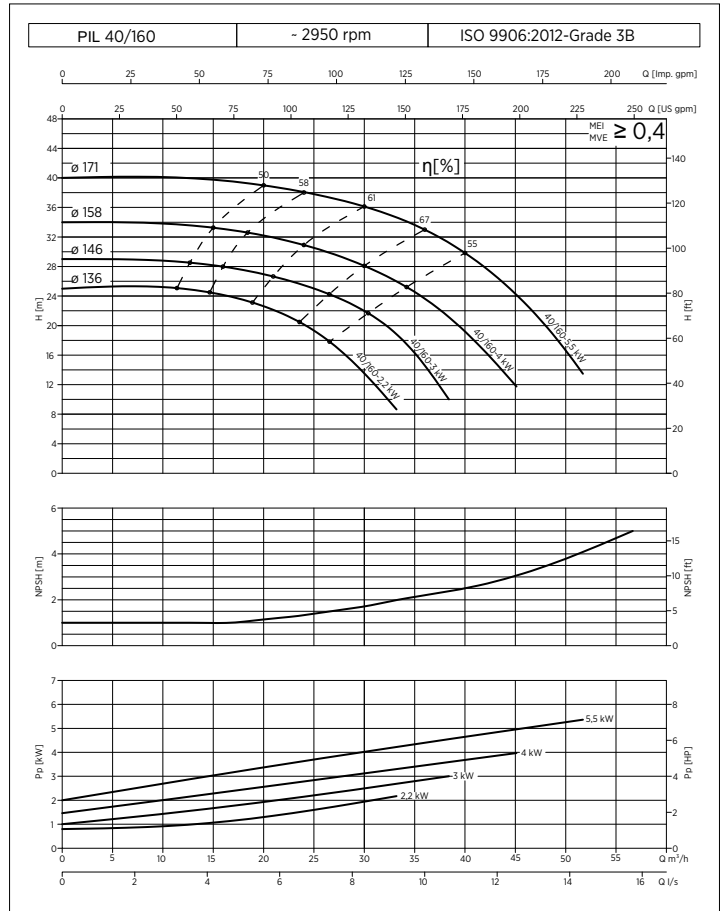
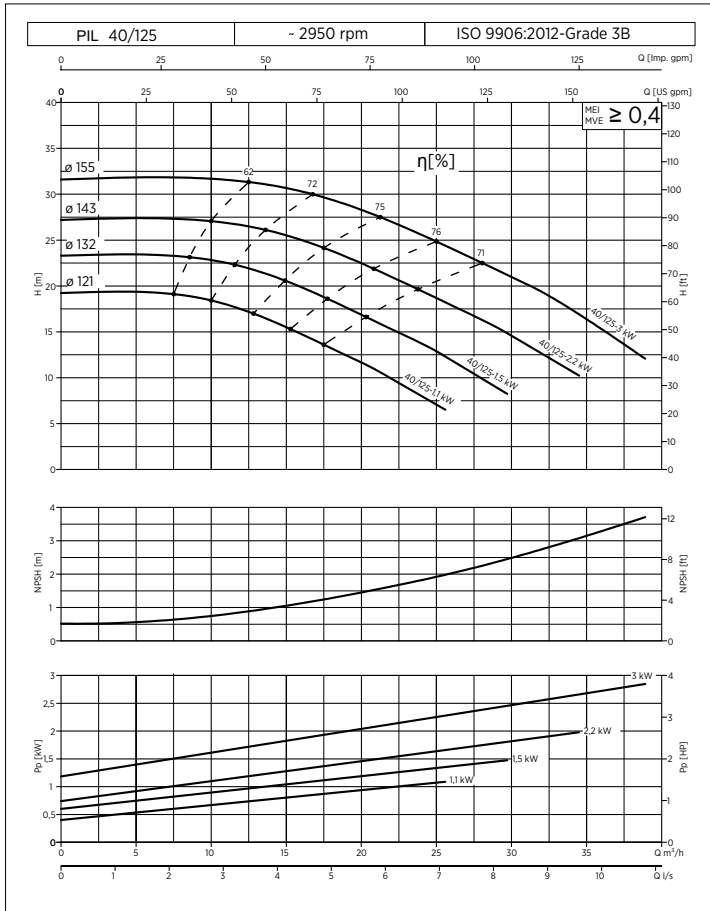

PIL SERIES HYDRAULIC PERFORMANCE CURVES

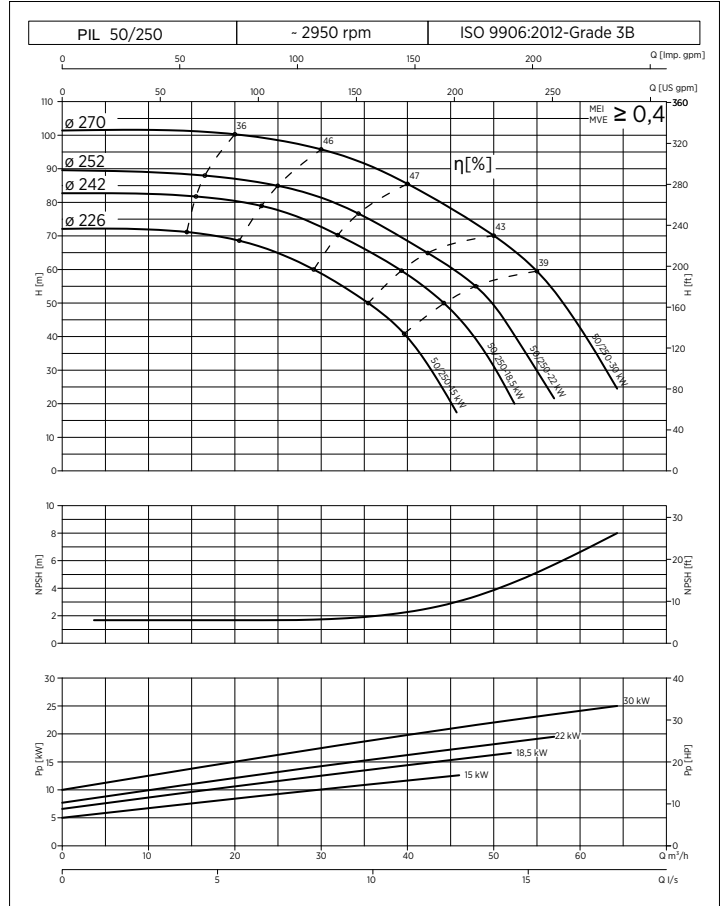
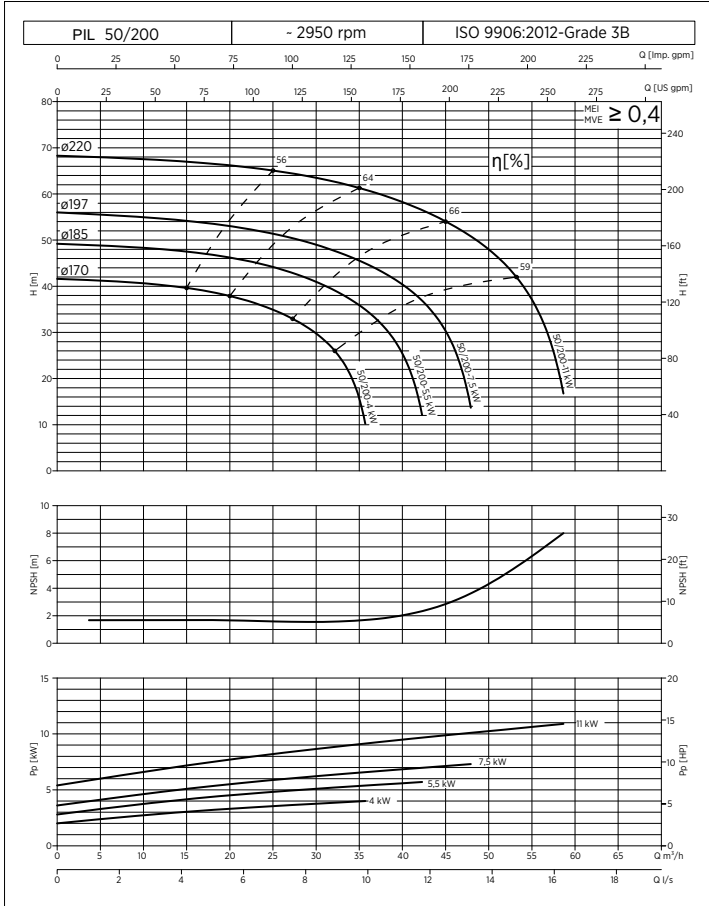
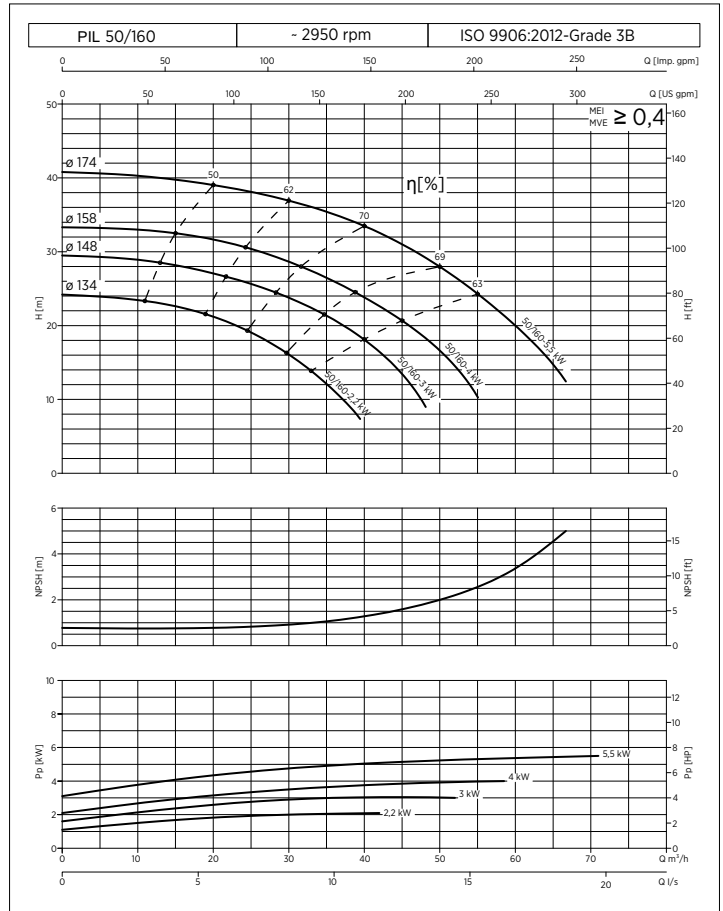
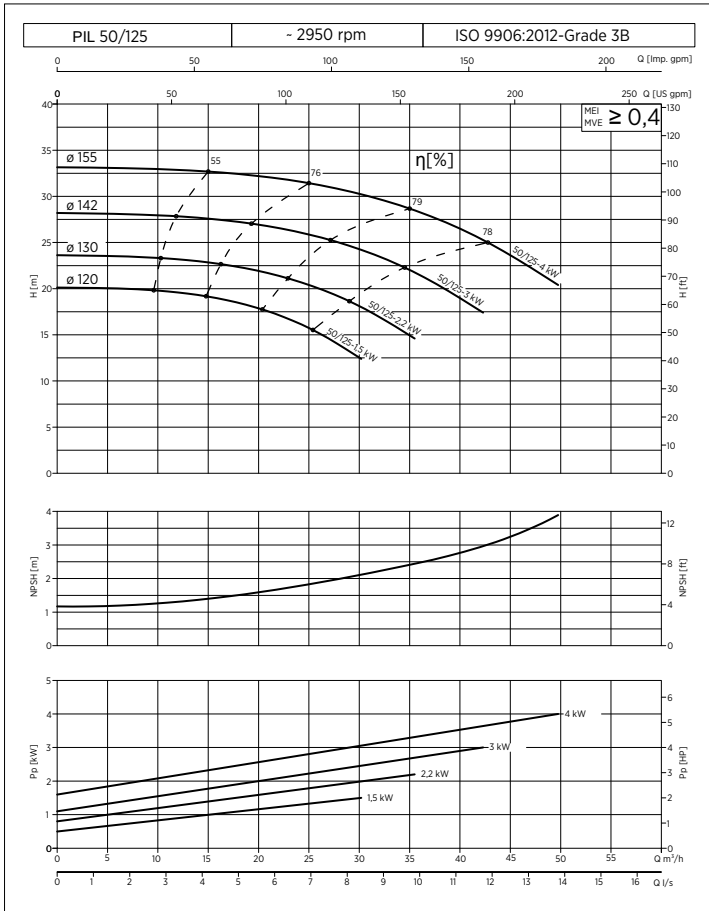

PIL SERIES HYDRAULIC PERFORMANCE CURVES

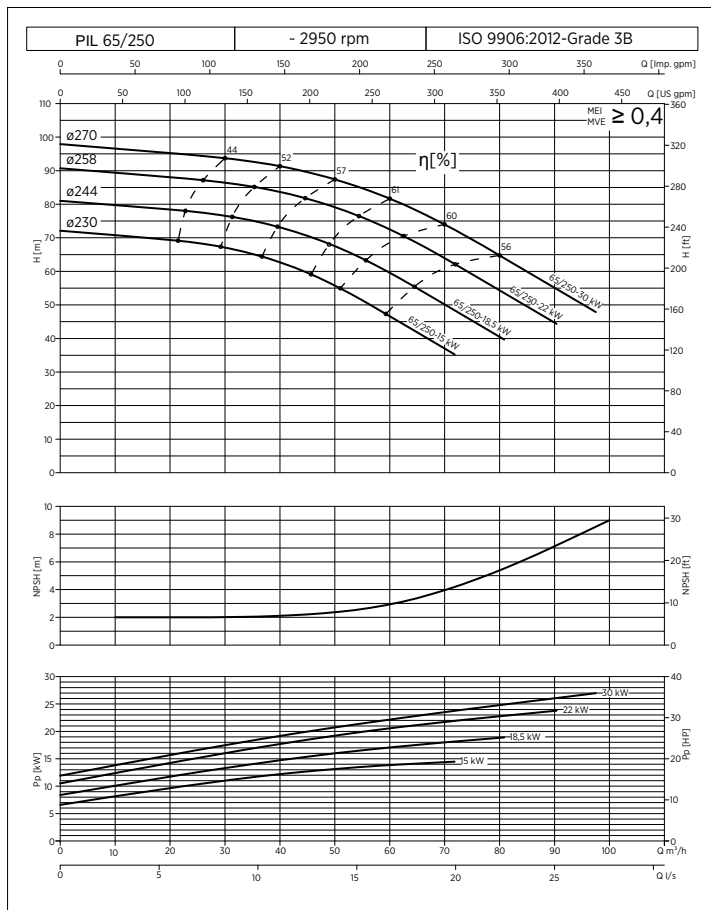
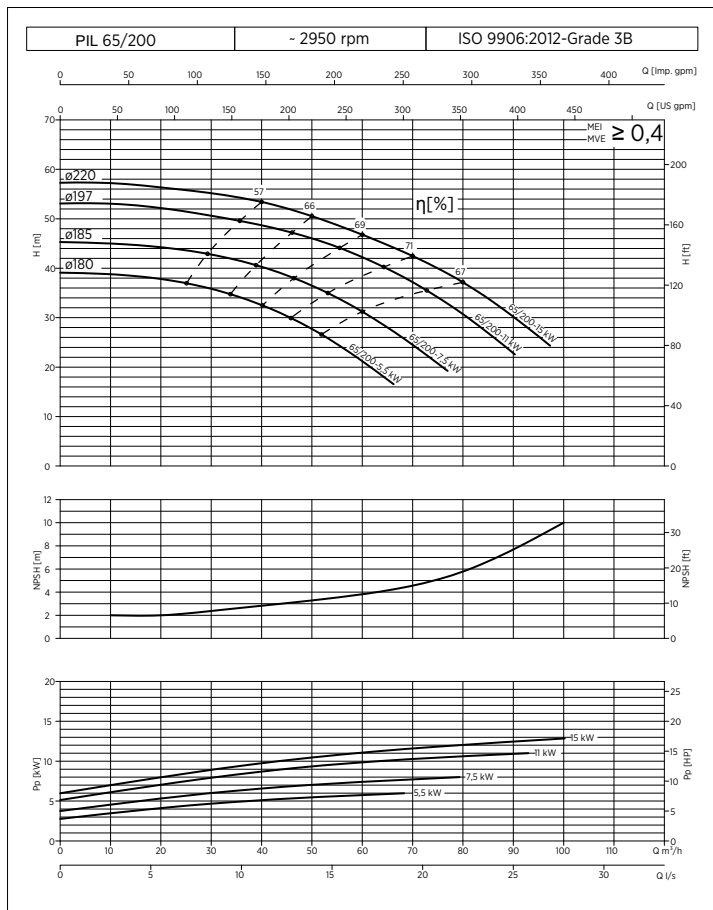
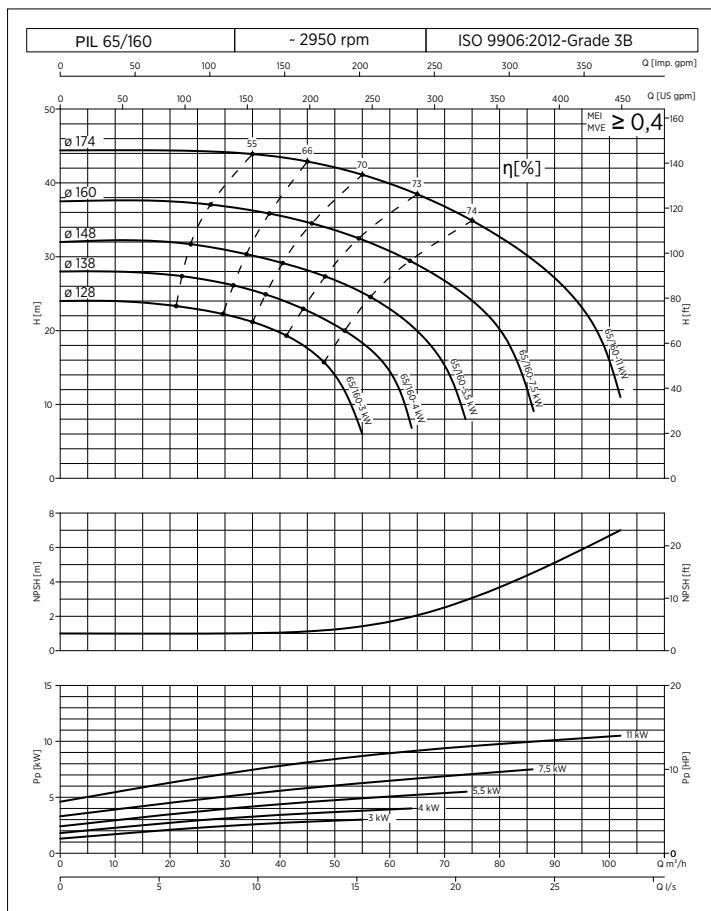
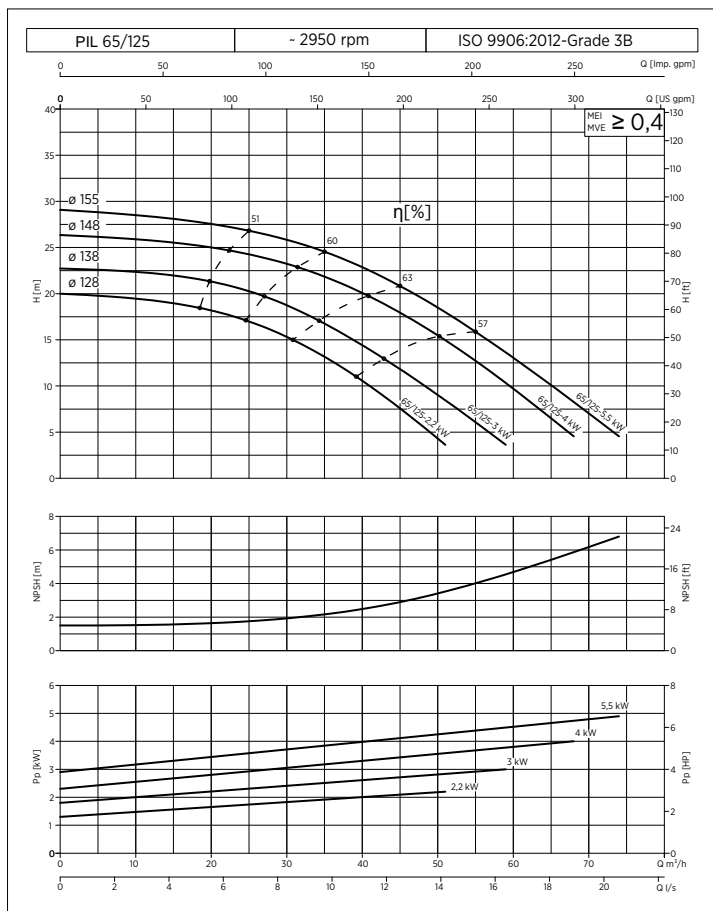

PIL SERIES HYDRAULIC PERFORMANCE CURVES

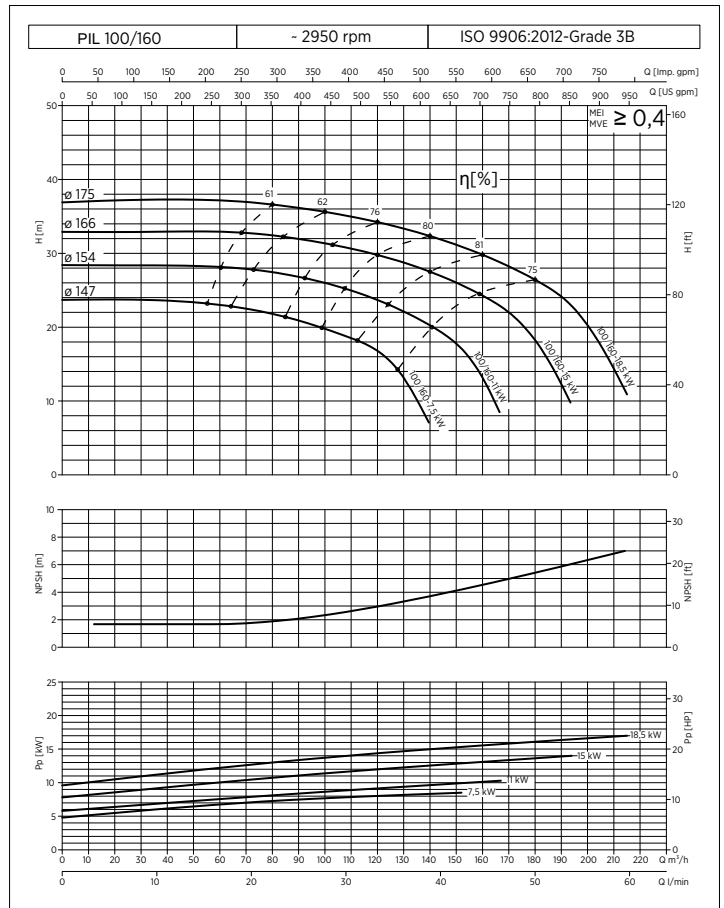
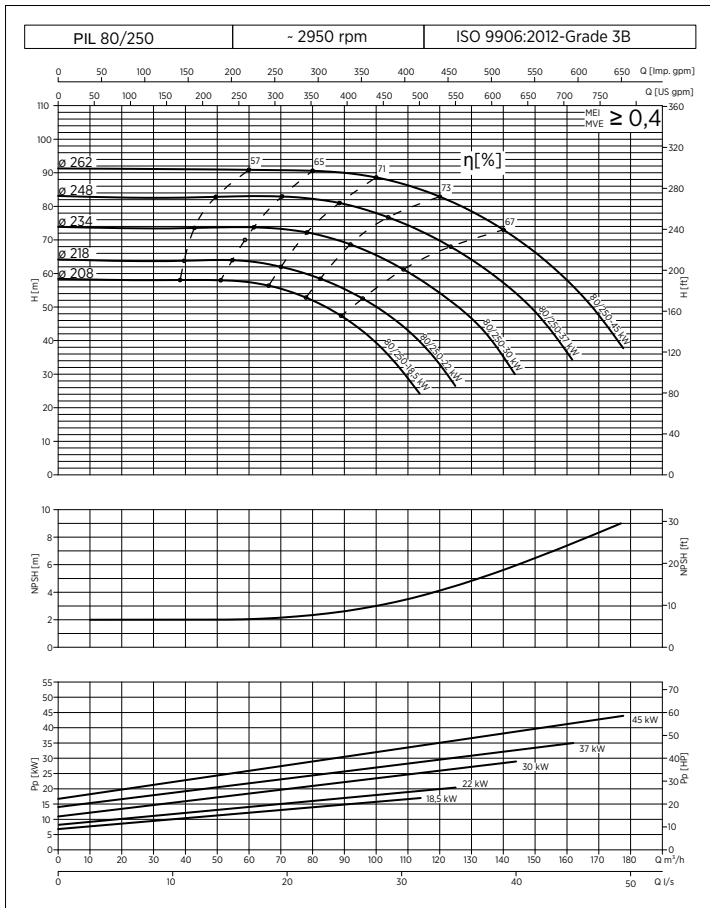
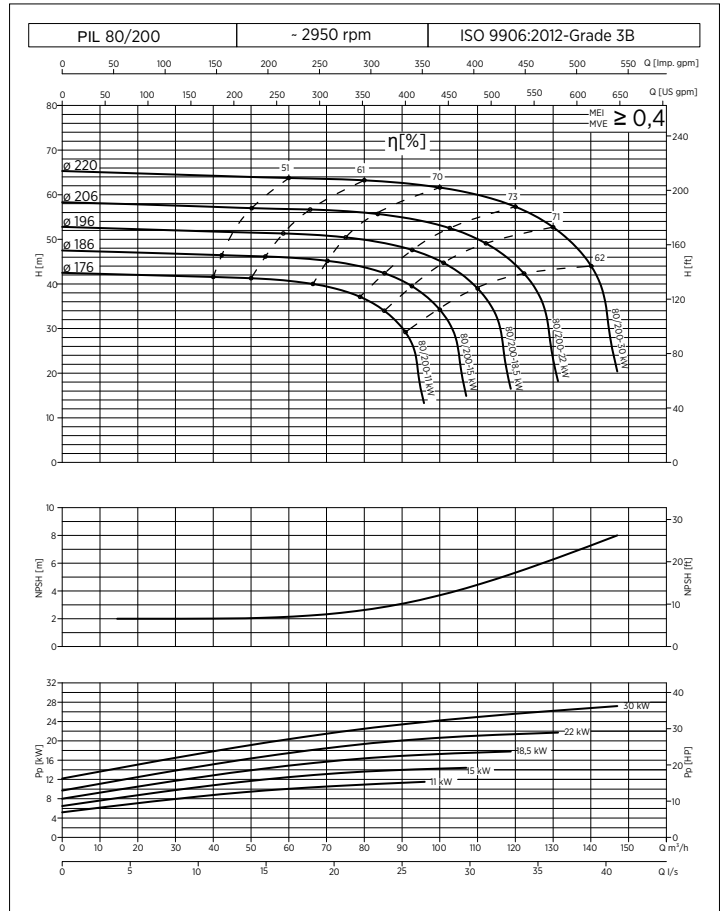
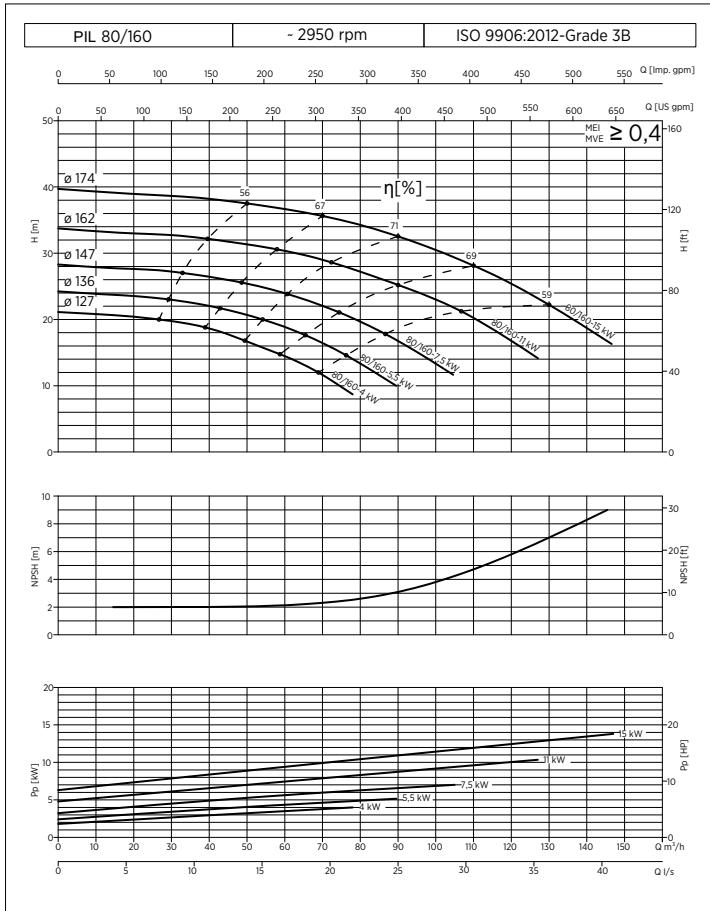

PIL SERIES HYDRAULIC PERFORMANCE CURVES

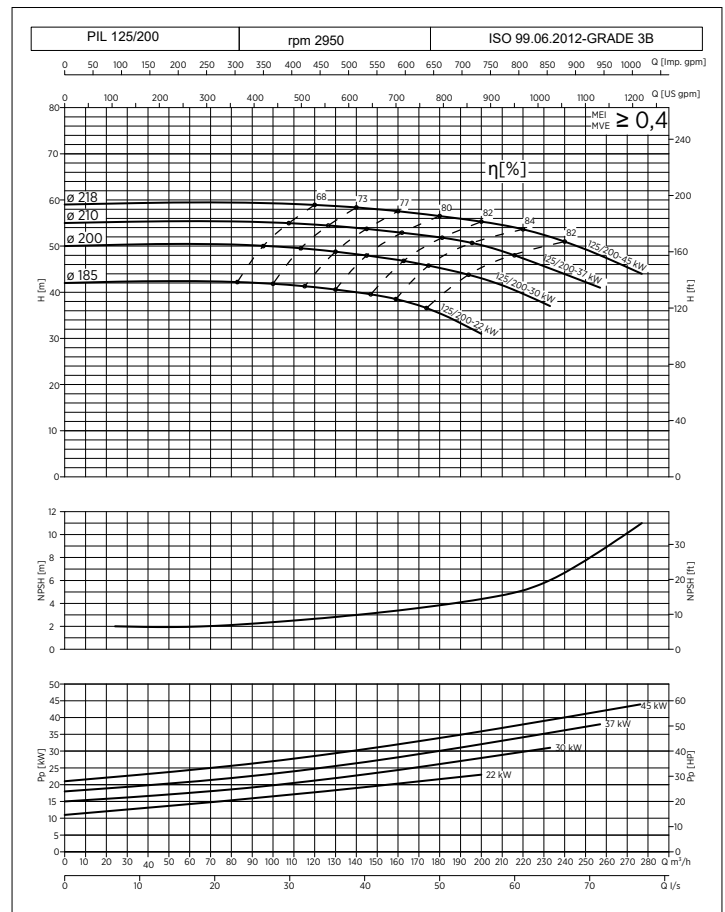
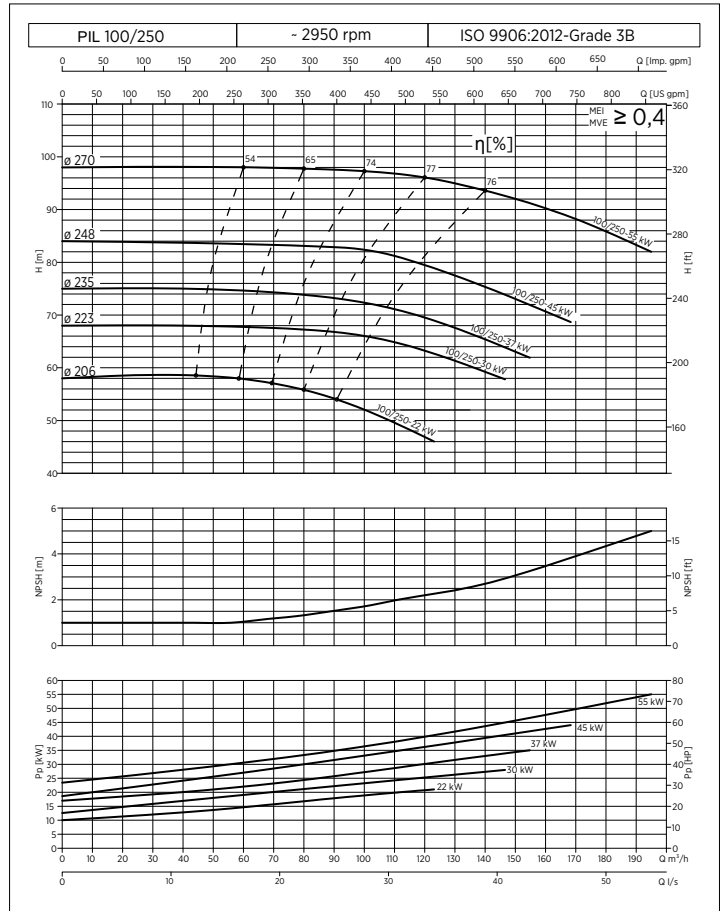
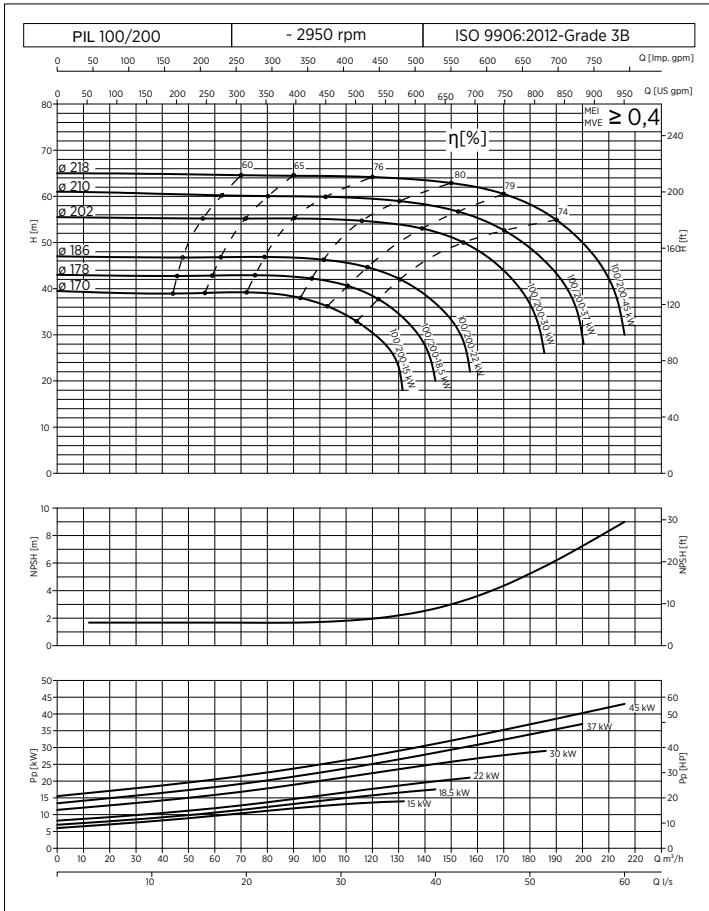

DIMENSIONS AND WEIGHTS

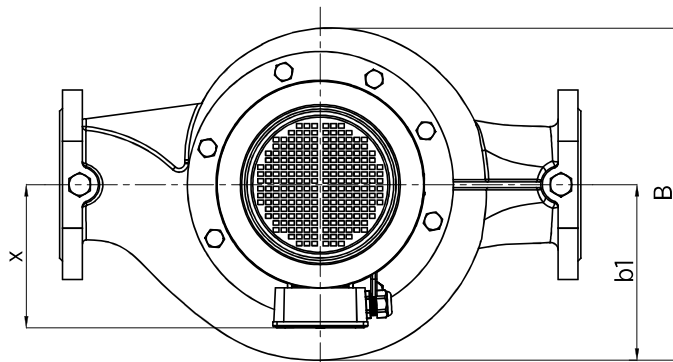
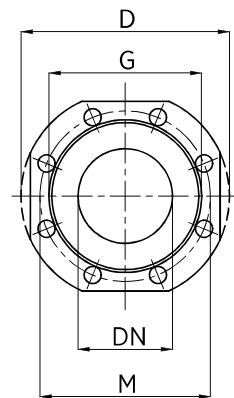
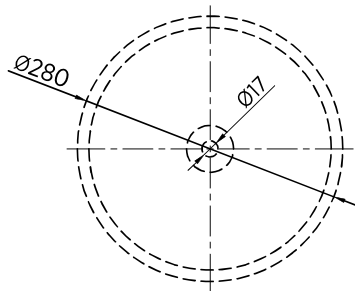
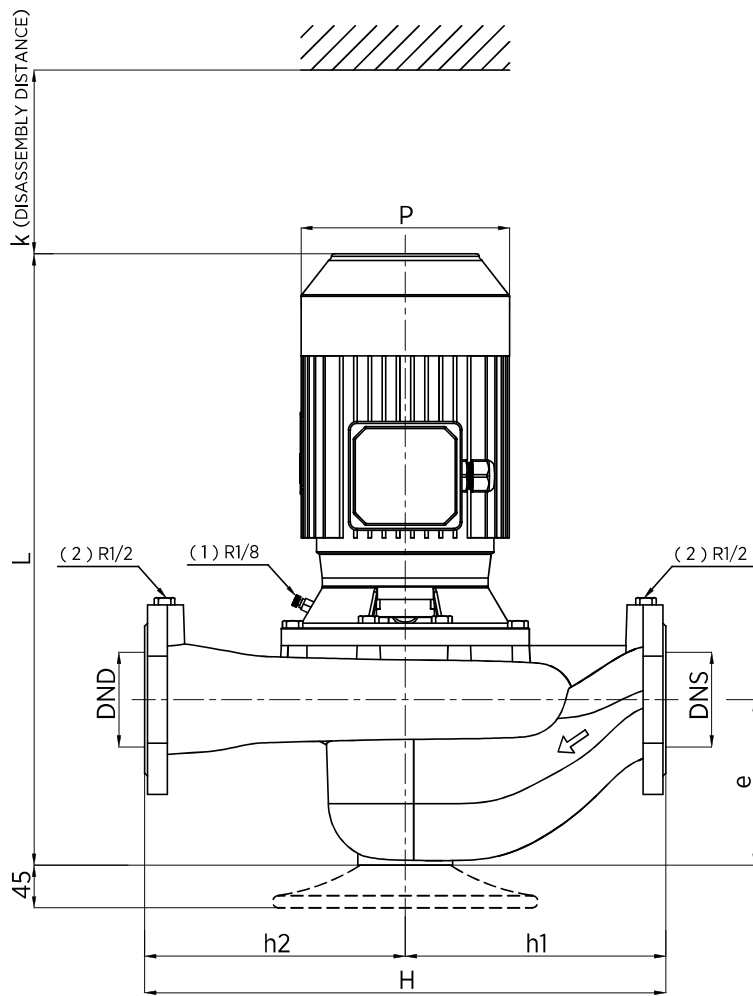

DN	D	M	G	HOLE		Max. Thickness
				N°	Ø	
40	150	110	88	4	18	18
50	165	125	102	4	18	20
65	185	145	122	4	18	20
80	200	160	138	8	18	22
100	220	180	158	8	18	22
125	250	210	188	8	18	22

(1) R 1/8 AIR DISCHARGE VALVE

(2) R 3/8 PRESSURE GAUGE CONNECTION

40, 50, 65, 80, 100, 125 SERIES DIMENSIONS AND WEIGHTS 4 POLES MOTOR (1450 rpm)

PUMP MODEL		DIMENSIONS (mm)												WEIGHT kg			
		DND	DNS	e	h1	h2	Hmax	B	b1	L	P	k	x				
40-125/02	40	40	40	105	160	140	300	215	115	410	140	100	110	30			
40-125/03														32			
40-125/05*														32			
40-160/03														32			
40-160/05*														32			
40-160/07														36			
40-200/07				41													
40-200/11				44													
40-200/15				47													
40-250/11				59													
40-250/15				62													
40-250/22*				64													
40-250/30				72													
50-125/02				50	50	50	110	170	150	320	230	125	420	140	120	110	32
50-125/03	35																
50-125/05*	33																
50-160/03	38																
50-160/05*	36																
50-160/07	41																
50-160/11*	44																
50-200/07	44																
50-200/11	47																
50-200/15	50																
50-200/22*	52																
50-250/11	57																
50-250/15	60																
50-250/22*	62																
50-250/30	70																
65-125/03	65	65	65				135	180	160	340	230	130	440	140	130	110	37
65-125/05*																	35
65-125/07																	40
65-160/05*																	39
65-160/07																	44
65-160/11																	47
65-160/15							50										
65-200/07							49										
65-200/11							52										
65-200/15				55													
65-200/22*				57													
65-250/15				66													
65-250/22*				68													
65-250/30				76													
65-250/40				82													
80-160/07				80	80	80	150	220	220	440	285	150	550	155	140	120	51
80-160/11																	54
80-160/15																	57
80-160/22*	59																
80-200/15	59																
80-200/22*	61																
80-200/30	68																
80-200/40	74																
80-250/30	85																
80-250/40	91																
80-250/55*	107																
80-250/75	109																
100-160/11	100	100	100				155	250	250	500	315	170	580	175	150	130	63
100-160/15																	66
100-160/22*				68													
100-160/30				75													
100-200/30				89													
100-200/40				96													
100-200/55*				112													
100-200/75				115													
100-250/40				103													
100-250/55*				119													
100-250/75				121													
100-250/110*				142													
125-200/30				103													
125-200/40				109													
125-200/55*	125																
125-200/75	127																
125-250/55*	135																
125-250/75	145																
125-250/110*	171																
125-250/150	222																