

Submersible Electric Pumps for pumping sewage

The DL series electric pumps come with single-channel or Vortex impeller (DLV), and are designed to handle solids-laden wastewater, with up to 22 m head and 42 m³/h delivery. 0,6 kW to 1,5 kW rated power. Solids handled up to 50 mm in diameter.

DL Series



APPLICATIONS

- Pumping of sewage with suspended solids and filaments.
- Emptying of sumps, septic tanks and wastewater discharge tanks.
- Draining of flooded excavations and marshy ground.

SPECIFICATIONS

- **Maximum liquid temperature:**
 - 50°C with fully submerged pump.
 - 25°C with partially submerged pump.
- **Mechanical seal** protected by **sand labyrinth.**
- Maximum dimension of **suspended solids:**
 - 45 mm for **DL80, DL90, DL105, MINIVORTEX, VORTEX.**
 - 50 mm for **DL109, DL125, DLV100, DLV115.**
- **Motor** in a dielectric non-toxic **oil bath**, which ensures the lubrication of the ball bearings and a more efficient cooling.

- **Power cord: H07RN-F.**
 - single-phase: with plug.
 - three-phase: without plug.
- **Insulation class 155°C (F).**
- **IPX8 protection.**
- **Maximum immersion depth: 5 m.**
- **Versions:**
 - Single-phase: 220-240V, 50Hz 2 poles.
 - Three-phase: 220-240V, 50Hz 2 poles. 380-415V, 50Hz 2 poles.
- **The single-phase versions** feature:
 - **capacitor** housed in a box on the power cord + 1,5 m. power cord with plug.
 - **thermal overload protection** to stop pump supply in case of overheating.
- CG versions (single-phase with pre-assembled float switch), 60 Hz single-phase and three-phase versions, versions with various power cord lengths and various plugs are available on request.

DL - DLV SERIES IDENTIFICATION CODE

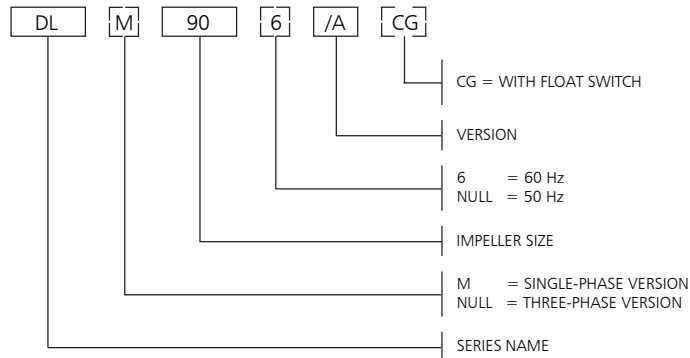

EXAMPLE : DLM 90/A
DL Series electric pump, impeller size 90,
50 Hz version, single-phase, /A version.

SINGLE-PHASE RATING PLATE

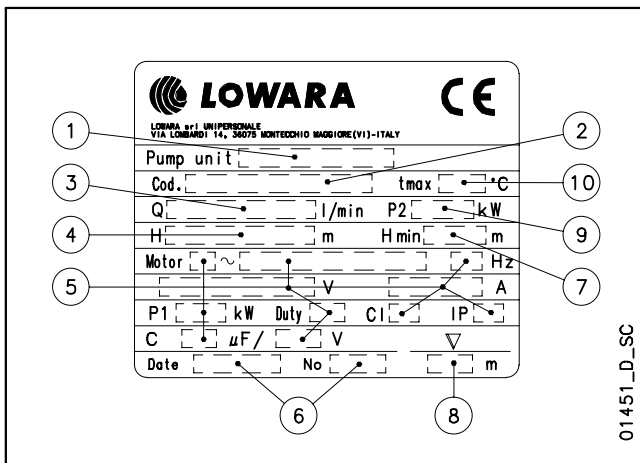

LEGEND

- 1 - Electric pump type
- 2 - Code
- 3 - Delivery range
- 4 - Head range
- 5 - Motor type
- 6 - Date of manufacture and serial number
- 7 - Minimum head
- 8 - Maximum immersion depth
- 9 - Rated output
- 10 - Maximum liquid temperature

THREE-PHASE RATING PLATE

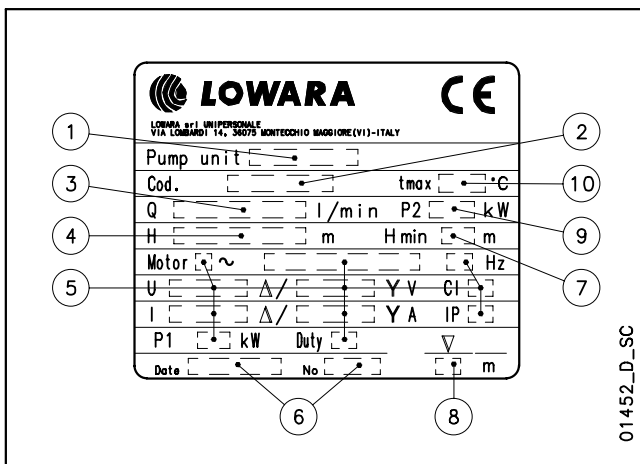

DL-VORTEX SERIES
LIST OF MODELS AND TABLE OF MATERIALS

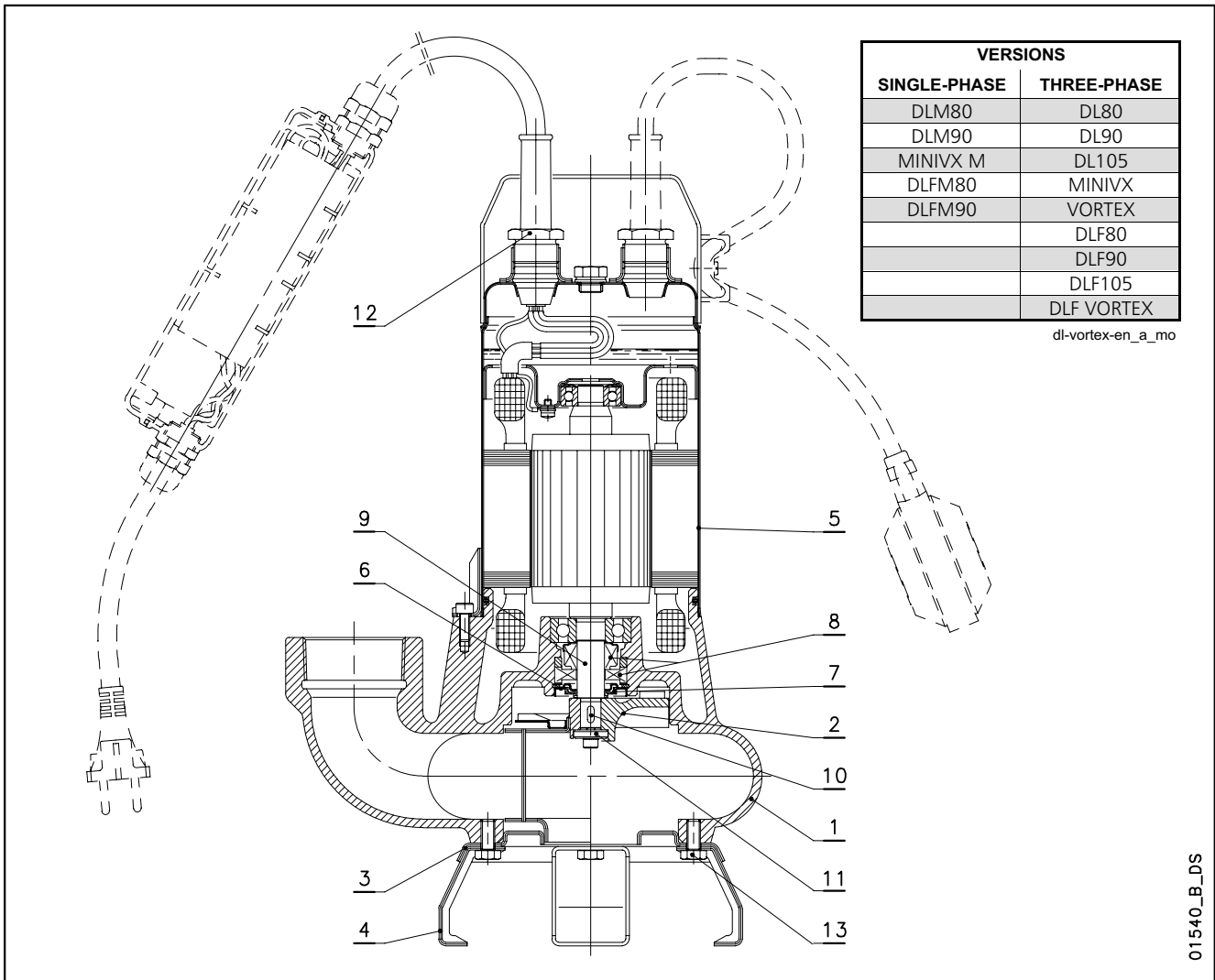

REF. N.	NAME	MATERIAL	REFERENCE STANDARDS	
			EUROPE	USA
1	Pump body	Cast iron	EN 1561-GJL-200(JL1030)	ASTM Class 25
2	Vortex impeller	Cast iron	EN 1561-GJL-200(JL1030)	ASTM Class 25
	Single-channel impeller	Stainless steel	EN 10088-1-X5CrNi18-10 (1.4301)	AISI 304
3	Suction flange	Stainless steel	EN 10088-1-X5CrNi18-10 (1.4301)	AISI 304
4	Support foot	Stainless steel	EN 10088-1-X5CrNi18-10 (1.4301)	AISI 304
5	Motor casing	Stainless steel	EN 10088-1-X5CrNi18-10 (1.4301)	AISI 304
6	Labyrinth cover	Stainless steel	EN 10088-1-X5CrNi18-10 (1.4301)	AISI 304
7	Labyrinth insert	NBR (standard version)		
8	Mechanical seal	Carbon / Ceramic Alumina / NBR (standard version)		
9	Shaft end	Stainless steel	EN 10088-1-X5CrNi18-10 (1.4301)	AISI 304
10	Key	Stainless steel	EN 10088-1-X5CrNiMo17-12-2 (1.4401)	AISI 316
11	Washer	Stainless steel		AISI 303
12	Cable gland	Brass		
13	Screws	Stainless steel	EN 10088-1-X5CrNi18-10 (1.4301)	AISI 304

dl-vortex-en_b_tm

DL-DLV SERIES LIST OF MODELS AND TABLE OF MATERIALS

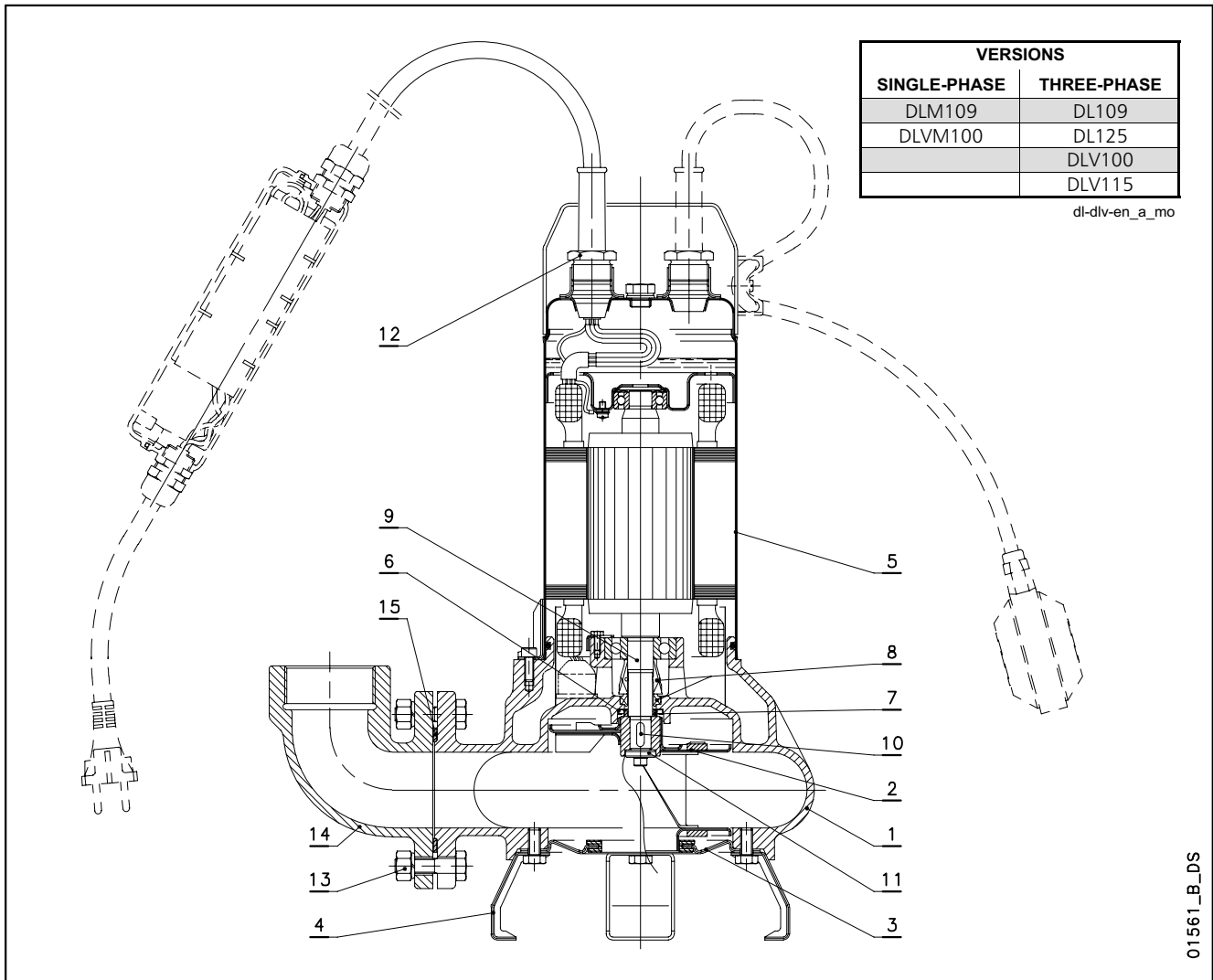

REF. N.	NAME	MATERIAL	REFERENCE STANDARDS	
			EUROPE	USA
1	Pump body	Cast iron	EN 1561-GJL-200(JL1030)	ASTM Class 25
2	Vortex impeller	Stainless steel	EN 10088-1-X5CrNi18-10 (1.4301)	AISI 304
	Single-channel impeller	Stainless steel	EN 10088-1-X5CrNi18-10 (1.4301)	AISI 304
3	Suction flange	Stainless steel	EN 10088-1-X5CrNi18-10 (1.4301)	AISI 304
4	Support foot	Stainless steel	EN 10088-1-X5CrNi18-10 (1.4301)	AISI 304
5	Motor casing	Stainless steel	EN 10088-1-X5CrNi18-10 (1.4301)	AISI 304
6	V-RING Cover	Stainless steel	EN 10088-1-X5CrNi18-10 (1.4301)	AISI 304
7	V16A Seal ring	NBR (standard version)		
8	Mechanical seal	Carbon / Ceramic Alumina / NBR (standard version)		
9	Shaft end	Stainless steel	EN 10088-1-X5CrNi18-10 (1.4301)	AISI 304
10	Key	Stainless steel	EN 10088-1-X5CrNiMo17-12-2 (1.4401)	AISI 316
11	Washer	Stainless steel		AISI 303
12	Cable gland	Brass		
13	Screws	Stainless steel	EN 10088-1-X5CrNi18-10 (1.4301)	AISI 304
14	Delivery connection	Cast iron	EN 1561-GJL-200(JL1030)	ASTM Class 25
15	Delivery connction gasket	Nitrile rubber		

**DL80 - DL90 - DL105 - MINIVORTEX - VORTEX SERIES
MECHANICAL SEAL**

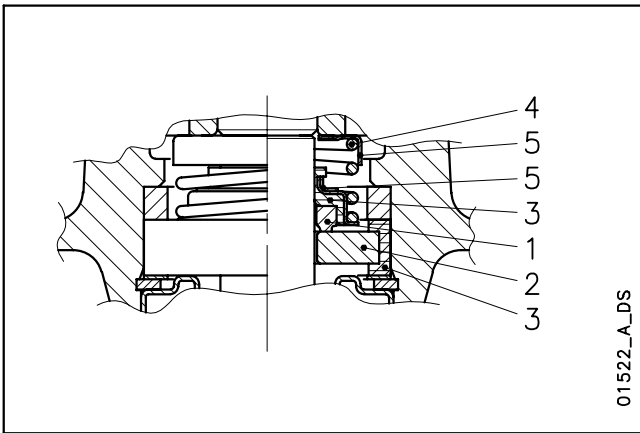

LIST OF MATERIALS

POSITION 1 - 2	POSITION 3	POSITION 4 - 5
B : Carbon	P : NBR	F : AISI 304
V : Ceramic Alumina		

dn-dl-dlv_ten-mec-en_c_tm

SEAL TYPES

TYPE	POSITION					TEMPERATURE (°C)
	1 ROTATING ASSEMBLY	2 FIXED ASSEMBLY	3 ELASTOMERS	4 SPRINGS	5 OTHER COMPONENTS	
STANDARD MECHANICAL SEAL						
BVPFF	B	V	P	F	F	0 +50

dn-dl-dlv_tipi-ten-mec-en_b_tc

DL109 - DL125 - DLV100 - DLV115 SERIES MECHANICAL SEAL

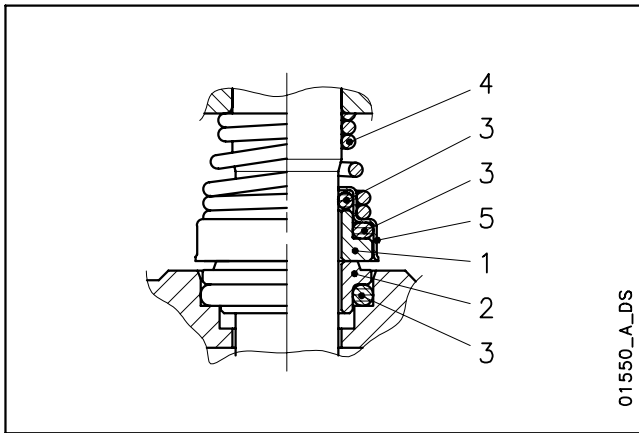

LIST OF MATERIALS

POSITION 1 - 2	POSITION 3	POSITION 4 - 5
B : Carbon	P : NBR	G : AISI 316
U ₃ : Tungsten Carbide	V : FPM	F : AISI 304
V : Ceramic Alumina		

dl-dlv_ten-mec-en_a_tm

SEAL TYPES

TYPE	POSITION					TEMPERATURE (°C)
	1 ROTATING ASSEMBLY	2 FIXED ASSEMBLY	3 ELASTOMERS	4 SPRINGS	5 OTHER COMPONENTS	
STANDARD MECHANICAL SEAL						
VBPGF	V	B	P	G	F	0 +50
OTHER MECHANICAL SEAL TYPES						
U ₃ U ₃ VFF	U ₃	U ₃	V	F	F	0 +50

dl-dlv_tipi-ten-mec-en_b_tc

DL SERIES OPERATING CHARACTERISTICS AT 50 Hz

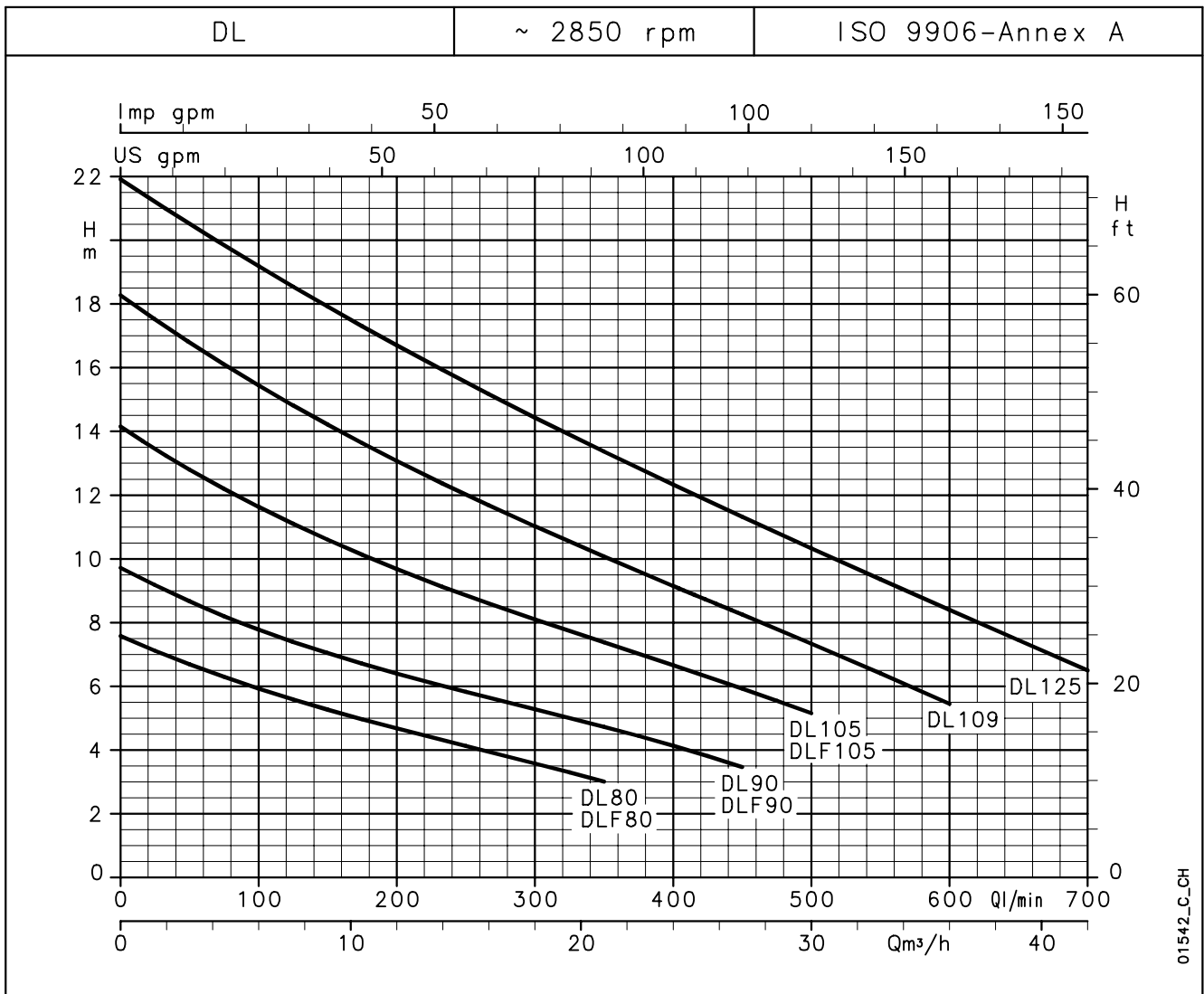

HYDRAULIC PERFORMANCE TABLE

PUMP TYPE	RATED POWER		Q = DELIVERY												
			l/min	0	100	150	200	250	300	350	400	450	500	600	700
			m³/h	0	6	9	12	15	18	21	24	27	30	36	42
H = TOTAL HEAD METRES COLUMN OF WATER															
DL(M) 80-DLF(M) 80	0,6	0,8	7,6	5,9	5,3	4,7	4,1	3,6	3,0						
DL(M) 90-DLF(M) 90	0,6	0,8	9,7	7,8	7,0	6,4	5,8	5,3	4,7	4,1	3,5				
DL 105 - DLF105	1,1	1,5	14,1	11,6	10,6	9,7	8,9	8,1	7,4	6,7	5,9	5,2			
DL(M) 109	1,1	1,5	18,3	15,4	14,2	13,1	12,0	11,0	10,1	9,2	8,2	7,3	5,4		
DL 125	1,5	2	21,9	19,2	17,9	16,7	15,5	14,4	13,4	12,3	11,3	10,3	8,4	6,5	

These performances are valid for liquids with density $\rho = 1,0 \text{ kg/dm}^3$ and kinematic viscosity $\nu = 1 \text{ mm}^2/\text{s}$.

dl-2p50-en_b_th

ELECTRICAL DATA TABLE

PUMP TYPE	ABSORBED POWER*	ABSORBED CURRENT*	CAPACITOR
	kW	220-240 V A	$\mu\text{F} / 450 \text{ V}$
SINGLE-PHASE			
DLM80-DLFM80	0,79	3,91	25
DLM90-DLFM90	0,89	4,27	25
-	-	-	-
DLM109	1,55	6,87	35
-	-	-	-

PUMP TYPE	ABSORBED POWER*	ABSORBED CURRENT*	ABSORBED CURRENT*
	kW	220-240 V A	380-415 V A
THREE-PHASE			
DL80-DLF80	0,8	-	2,09
DL90-DLF90	0,92	3,81	2,2
DL105-DLF105	1,43	4,66	2,69
DL109	1,54	5,44	3,14
DL125	2,14	6,58	3,8

*Maximum values within operating range.

dl-2p50-en_b_te

DLV SERIES OPERATING CHARACTERISTICS AT 50 Hz

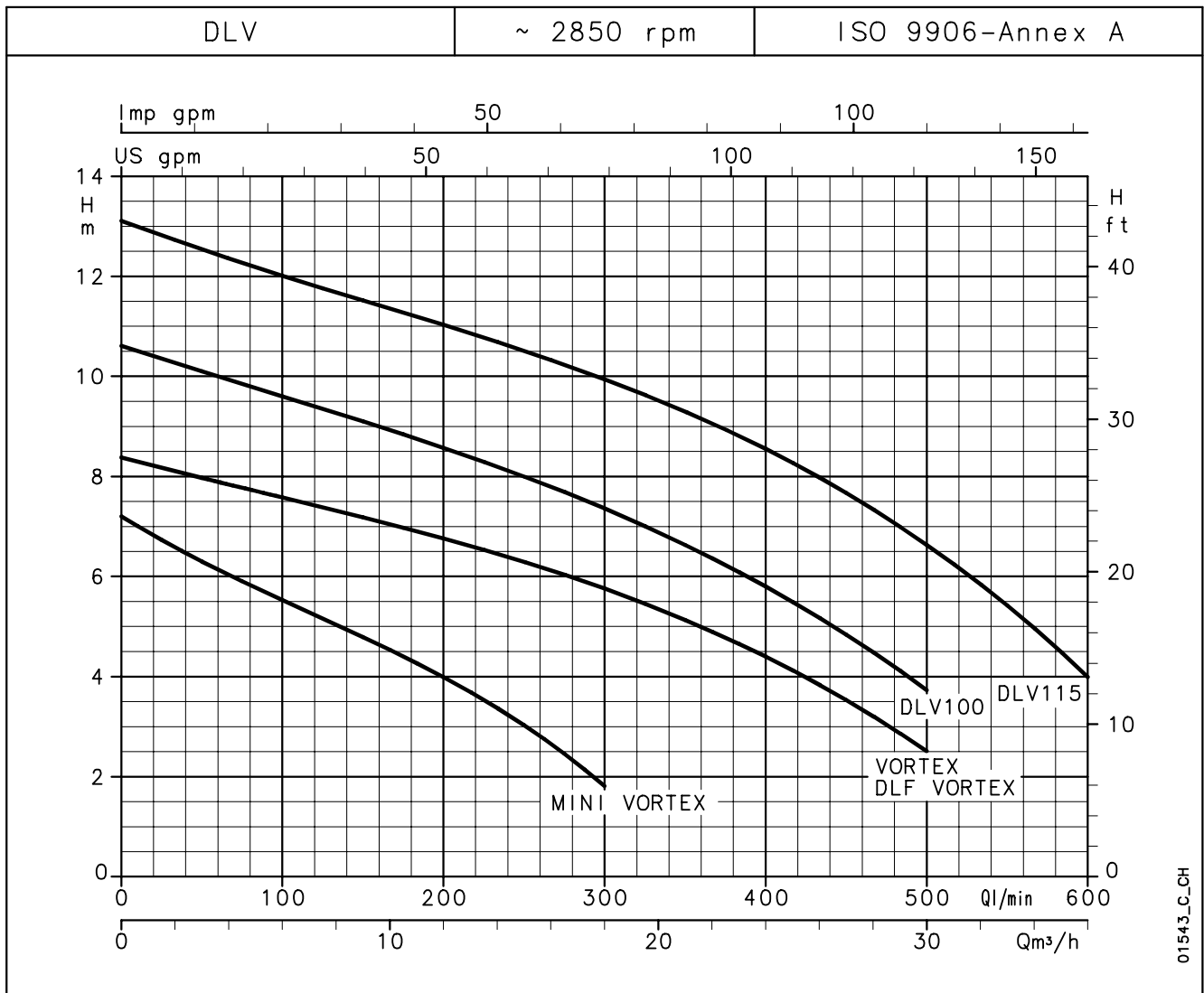

HYDRAULIC PERFORMANCE TABLE

PUMP TYPE	RATED POWER		Q = DELIVERY												
			l/min	0	50	100	150	200	250	300	350	400	450	500	600
			m ³ /h	0	3	6	9	12	15	18	21	24	27	30	36
			H = TOTAL HEAD METRES COLUMN OF WATER												
MINI VORTEX(M)	0,6	0,8	7,2	6,3	5,5	4,8	4,0	3,0	1,8						
VORTEX-DLF VORTEX	1,1	1,5	8,4	8,0	7,6	7,2	6,8	6,3	5,8	5,1	4,4	3,5	2,5		
DLV(M) 100	1,1	1,5	10,6	10,1	9,6	9,1	8,6	8,0	7,4	6,6	5,8	4,8	3,7		
DLV 115	1,5	2	13,1	12,5	12,0	11,5	11,0	10,5	9,9	9,3	8,5	7,7	6,6	4,0	

These performances are valid for liquids with density $\rho = 1,0 \text{ kg/dm}^3$ and kinematic viscosity $\nu = 1 \text{ mm}^2/\text{s}$.

dlv-2p50-en_b_th

ELECTRICAL DATA TABLE

PUMP TYPE	ABSORBED POWER*	ABSORBED CURRENT*	CAPACITOR
SINGLE-PHASE	kW	220-240 V A	$\mu\text{F} / 450 \text{ V}$
MINI VORTEX M	1,05	4,82	25
-	-	-	-
DLVM100	1,64	7,30	35
-	-	-	-

PUMP TYPE	ABSORBED POWER*	ABSORBED CURRENT*	ABSORBED CURRENT*
THREE-PHASE	kW	220-240 V A	380-415 V A
MINI VORTEX	1,10	-	2,36
VORTEX-DLF VORTEX	1,66	5,11	2,95
DLV 100	1,65	5,63	3,25
DLV 115	2,25	6,81	3,93

*Maximum values within operating range.

dlv-2p50-en_b_te

DL - VORTEX SERIES DIMENSIONS AND WEIGHTS

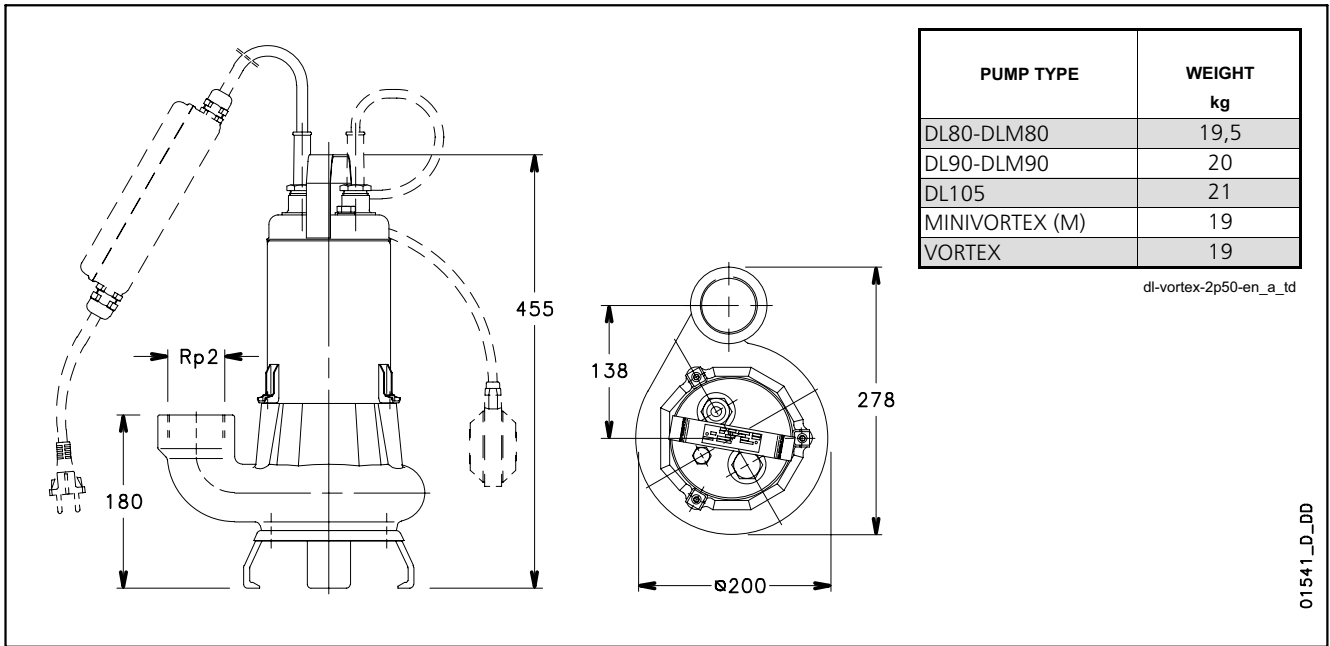

DLF SERIES INSTALLATION WITH SD LOWERING DEVICE

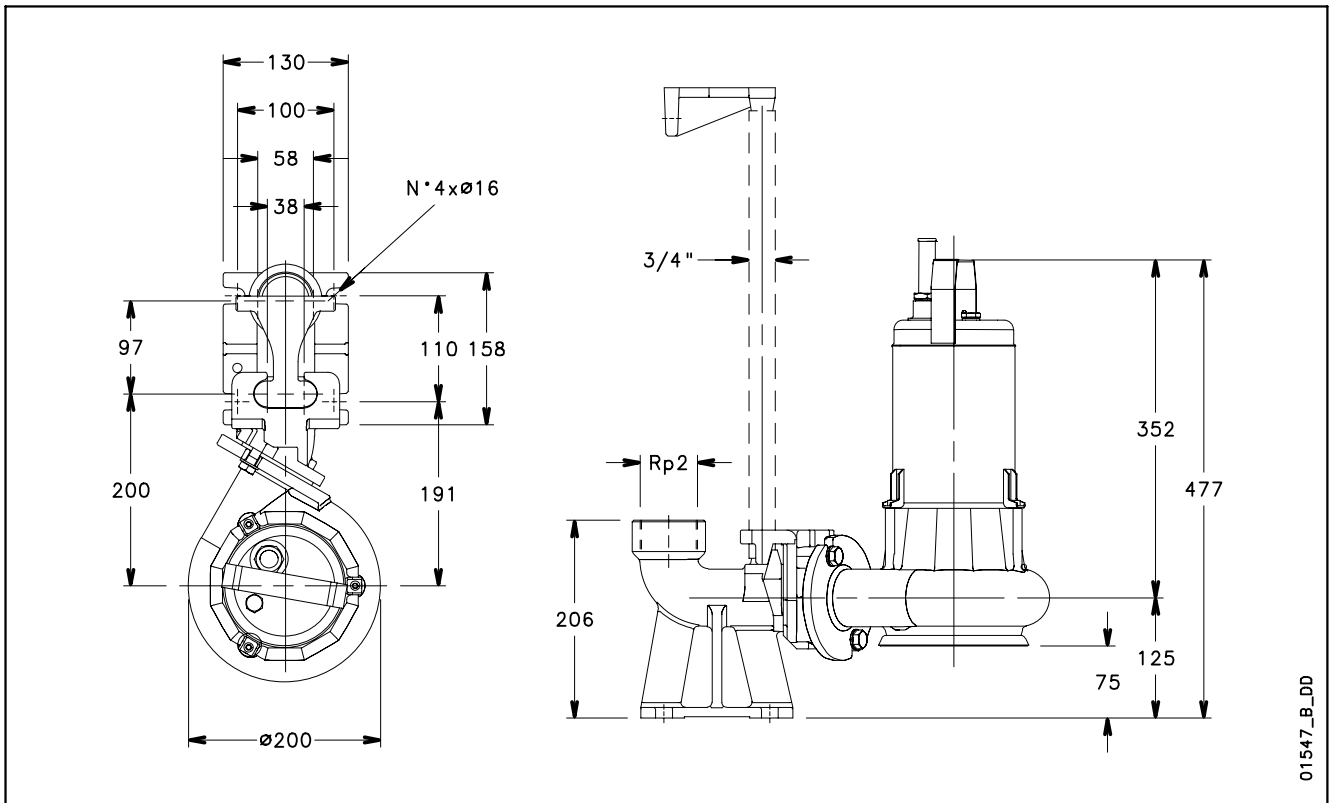

**DL - DLV SERIES
DIMENSIONS AND WEIGHTS**

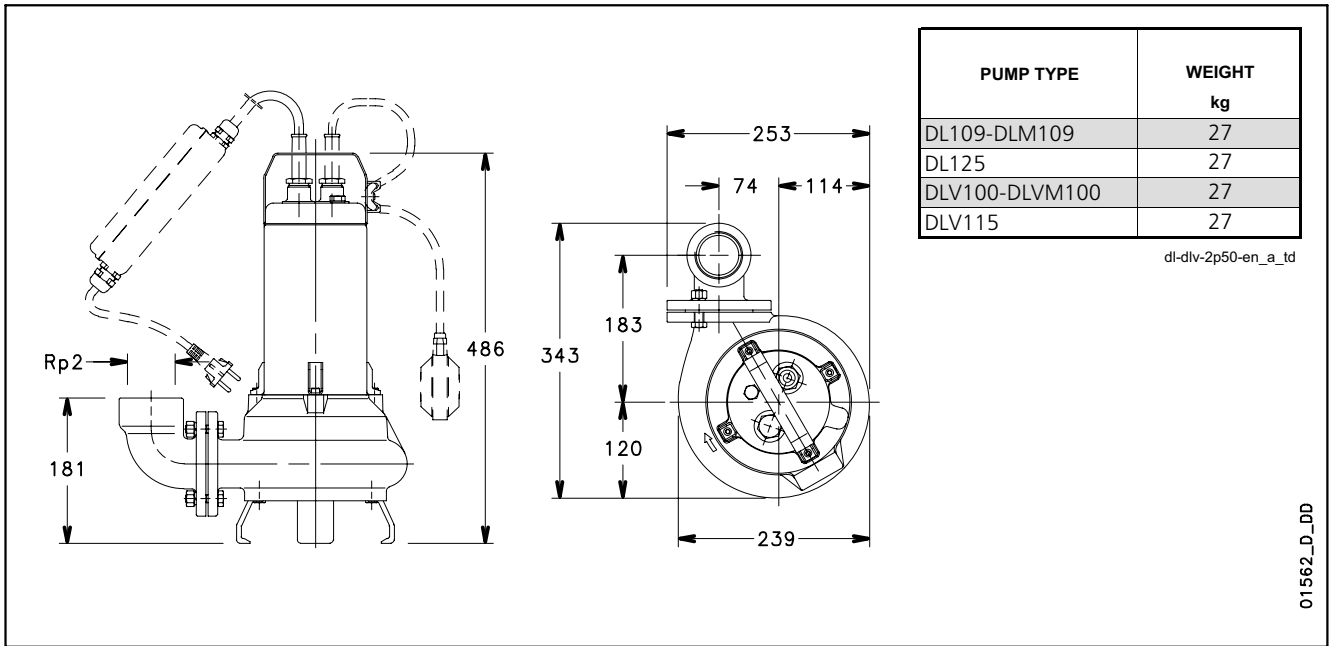

**DL-DLV SERIES
INSTALLATION WITH SD LOWERING DEVICE**

