



## Pumps

- Gasoline Water Pump
- Gasoline Sewage Pump
- Gasoline Cast Iron Centrifugal Pump
- Diesel Water Pump
- Gasoline Trash Pump
- Horizontal Engines

 LEO GROUP PUMP(ZHEJIANG) CO.,LTD. (Stock code: 002131)

2021 v2.0

No.1, 3rd Street, East Industry Center, Wenling, Zhejiang, China, 317511  
Tel: +86-576-8998 6360 Fax: +86-576-8998 9898 E-mail: export@leogroup.cn www.leogroup.cn

LEO reserves all the right of products modification without prior notification.

[www.leogroup.cn](http://www.leogroup.cn)

LEO GROUP PUMP(ZHEJIANG) CO.,LTD.





### Application

- To transfer clean water with liquid temperature between 0 and 40
- Applicable in water supply and drainage for factories, mines, municipal facilities as well as field irrigation, etc.

### Features

- New unique design with ergonomic feature
- Portable and compact pump frame
- High quality engine with excellent performance and long service life
- Impeller designed with high efficient hydraulic system
- Low fuel consumption

### Pump

- Anti-rust cast iron impeller and diffuser
- Max. Suction: 8 m, Suck 5 m needs 120 s
- Inlet/outlet: 25 mm/38 mm

### Engine

- Single cylinder, 2-stroke, Air-cooled
- Max. power: 1.6 HP
- Rated speed: 7500rpm
- Mixture ratio of fuel: 1:25 (2-stroke engine oil and 90 octane gasoline or higher)

### Identification Codes

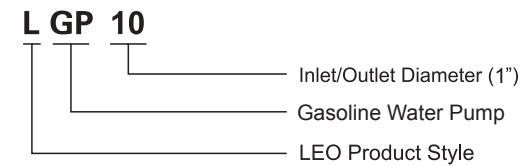

### Technical Data

Model	Power HP	Mixed Fuel tank L	Displacement cc	Engine	Q (m³/h)									
					0	2	4	6	8	10	12	14	15	
LGP10	1.6	1	42.7	G43	35	32.5	26.9	6	-	-	-	-	-	-
LGP15	1.6	1	42.7	G43	35	34.5	34	33	30	27.5	23.5	15	5	

### Hydraulic Performance Curves

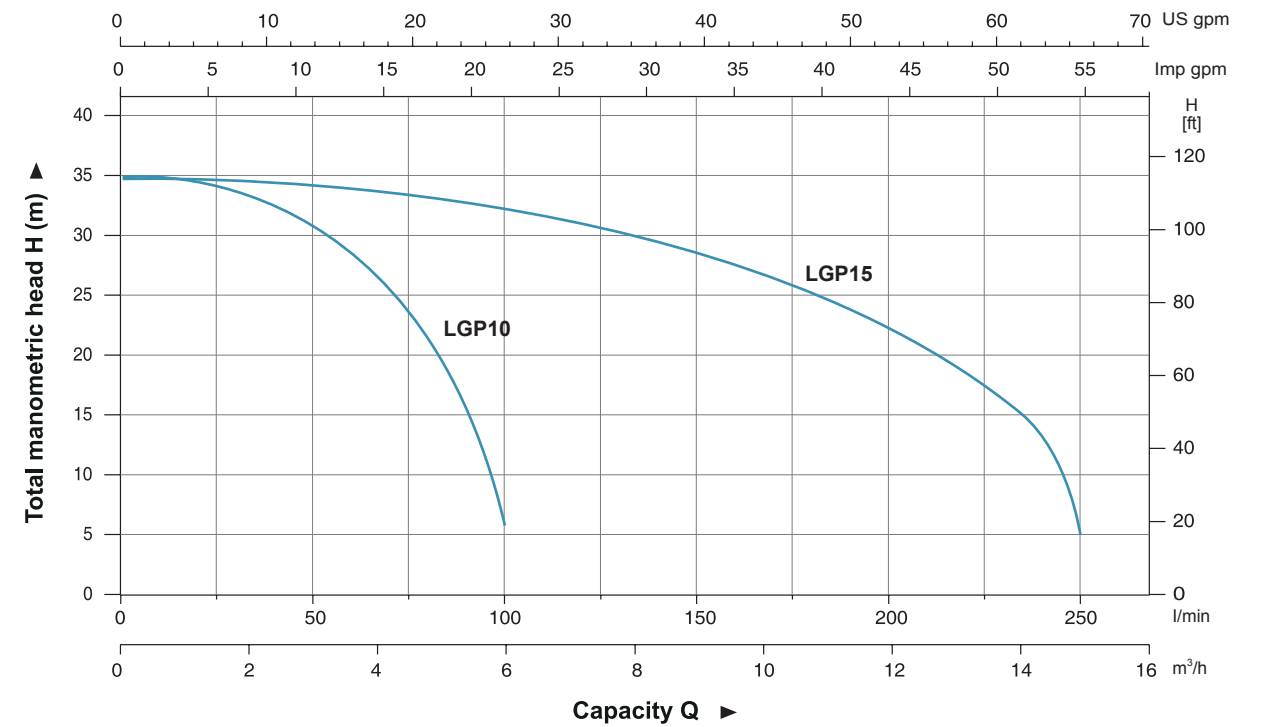

### Materials Table

No.	Part	Material
1	Frame	Steel
2	Throttle trigger	
3	Engine	
4	Crankshaft	
5	Bearing	
6	Seat connection	Aluminum
7	Pump cover	Aluminum
8	O-ring	NBR
9	Mechanical seal	Carbon/Ceramic
10	Impeller	HT200
11	Diffuser	HT200
12	O-ring	NBR
13	Plug	PP
14	Outlet	Aluminum
15	Seal	NBR
16	Non-return valve	NBR
17	Inlet	Aluminum
18	Pump body	Aluminum

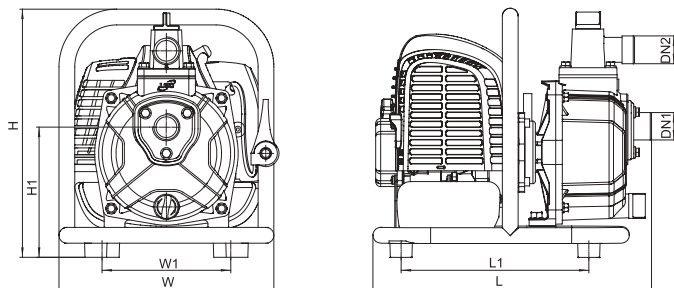
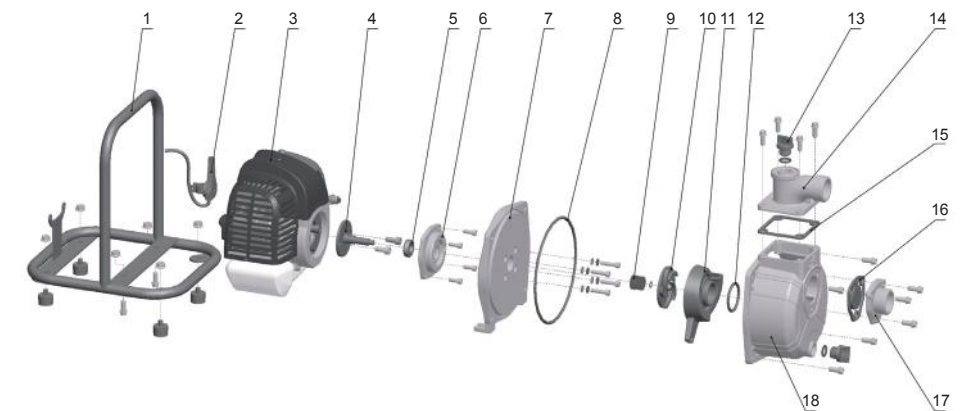

### Dimension

Model	DN1	DN2	L (mm)	W (mm)	H (mm)	L1 (mm)	W1 (mm)	H1 (mm)
LGP10	1"	1"	336	279	300	217.5	155	157
LGP15	1 1/2"	1 1/2"	344	279	345	233	175	180

### Package Information

Model	GW (Kgs)	L (mm)	W (mm)	H (mm)	Quantity (PCS/20 TEU)
LGP10	6.84	350	290	325	702
LGP15	8.27	355	290	370	681





### Application

- To transfer clean water with liquid temperature between 0 and 40
- Application in water supply and drainage for factories, mines, municipal facilities as well as field irrigation, etc.

### Features

- 4-stroke gasoline engine power performance, structural optimization and upgrading
- Ignition more convenient, more complete combustion, low energy consumption, more environmentally friendly
- Strengthened pump body ensures more durable and reliable service
- Better sealing effect by using special mechanical seal
- Impeller designed with high efficient hydraulic system

### Pump

- Anti-rust cast iron impeller and diffuser
- Max.Suction: 8 m , Suck 5 m needs 120 s
- Inlet/outlet: 25 mm , 38 mm

### Engine

- Single cylinder, 4-stroke, Air-cooled
- Max.power: 3 HP
- Rated speed: 3600 rpm

### Identification Codes

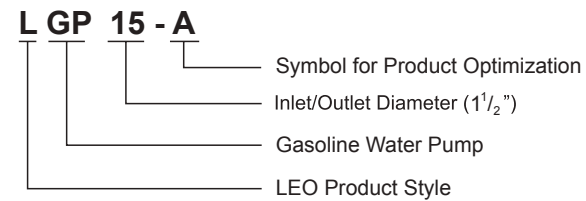

### Technical Data

Model	Power HP	Fuel tank L	Engine oil L	Displacement cc	Engine	Q (m³/h)									
						0	2	4	6	8	10	12	14	16	18
LGP10-A	3	1.8	0.35	79	G79	25	24	20.2	15	7.5	-	-	-	-	-
LGP15-A	3	1.8	0.35	87	G87	25	24.5	24	23	22	20	17	15	12	7.2

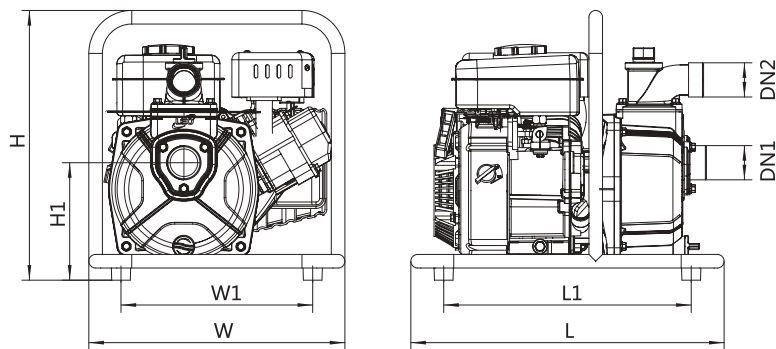

### Dimension

Model	DN1	DN2	L (mm)	W (mm)	H (mm)	L1 (mm)	W1 (mm)	H1 (mm)
LGP10-A	1"	1"	438	380	377	346	268	158
LGP15-A	1 1/2"	1 1/2"	438	380	377	346	268	164.2

### Hydraulic Performance Curves

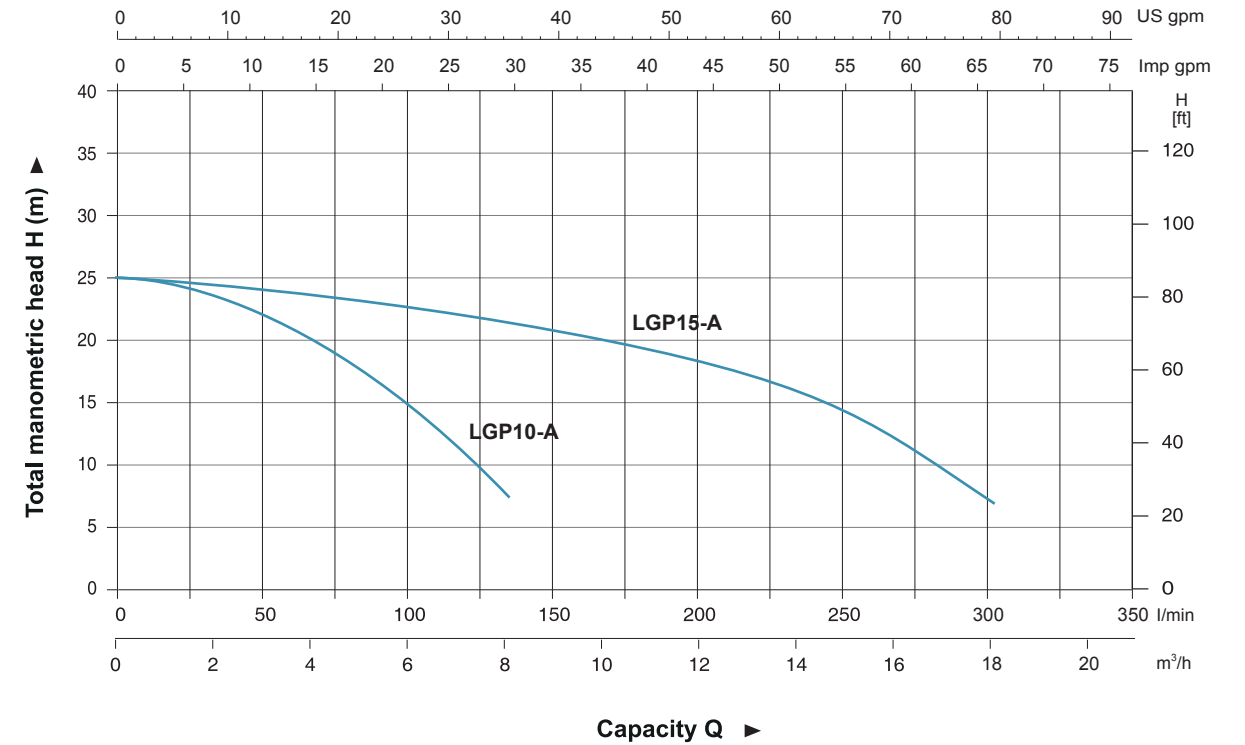

### Materials Table

No.	Part	Material
1	Frame	Steel
2	Engine	
3	Pump cover	Aluminum
4	O-ring	NBR
5	Mechanical seal	Carbon/Ceramic
6	Impeller	HT200
7	Diffuser	HT200
8	O-ring	NBR
9	Pump body	Aluminum
10	Seal	NBR
11	Plug	PP
12	Outlet	Aluminum
13	Non-return valve	NBR
14	Inlet	Aluminum

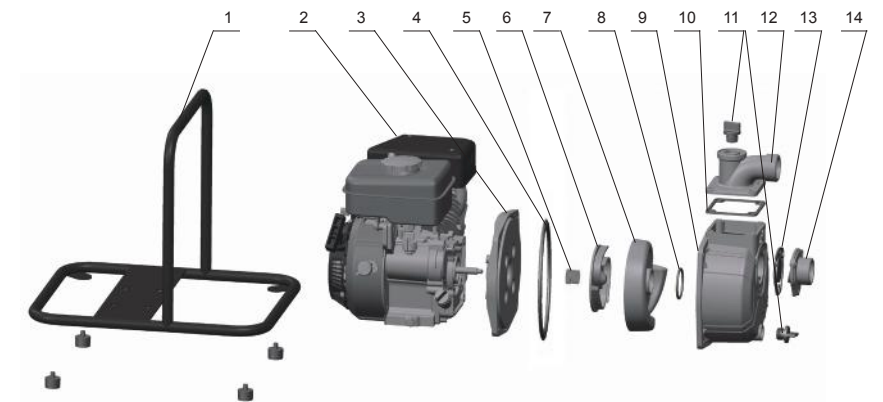

### Package Information

Model	GW (Kgs)	L (mm)	W (mm)	H (mm)	Quantity (PCS/20 TEU)
LGP10-A	13	464	378	400	330
LGP15-A	14.5	464	378	400	330







### Application

- To transfer clean water with liquid temperature between 0°C and 40°C
- Applicable in water supply and drainage for factories, mines, municipal facilities as well as field irrigation, etc.

### Features

- Strengthened pump body ensures more durable and reliable service
- Better sealing effect by using special mechanical seal
- 5-direction outlet for convenient use
- Improved starter handle for easier starting
- 20% increased loading quantity thanks to very compact design
- Less gasoline consumption

### Pump

- Anti-rust cast iron impeller and diffuser
- High quality forged steel crankshaft
- Max. suction: 8 m/120 s
- Inlet/outlet: 50 mm/80 mm

### Engine

- Single cylinder, 4-stroke, Air-cooled
- Max. power: 5.5 HP/6.5 HP
- Displacement: 163 cc/196 cc
- Rated speed: 3600 rpm

### Identification Codes

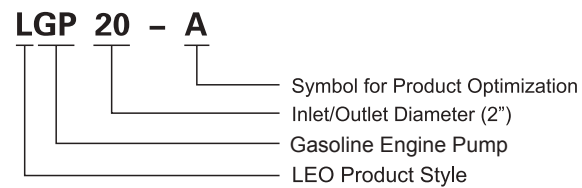

### Technical Data

MODEL	POWER HP	Q (m³/h) Q (l/min)	H (m)												
			0	5	10	15	20	25	30	35	40	45	50	55	60
LGP20-A	5.5		30	25.1	21.6	17.6	13.4	5.9	1.5	-	-	-	-	-	-
LGP30-A	6.5		30	28.4	27.5	26	24	22.5	20	17.5	15	12.5	8.5	6	3.5

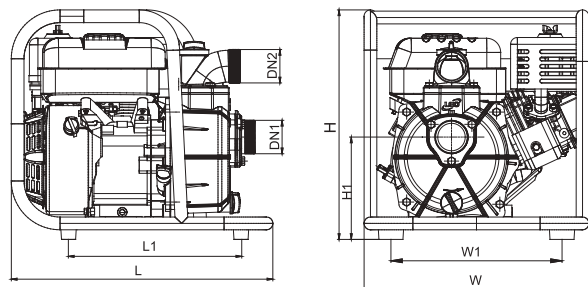

### Dimension

Model	DN1	DN2	L (mm)	W (mm)	H (mm)	L1 (mm)	W1 (mm)	H1 (mm)
LGP20-A	2"	2"	462	397.5	405.5	306.5	302.5	181
LGP30-A	3"	3"	462	397.5	405.5	306.5	302.5	189

### Hydraulic Performance Curves

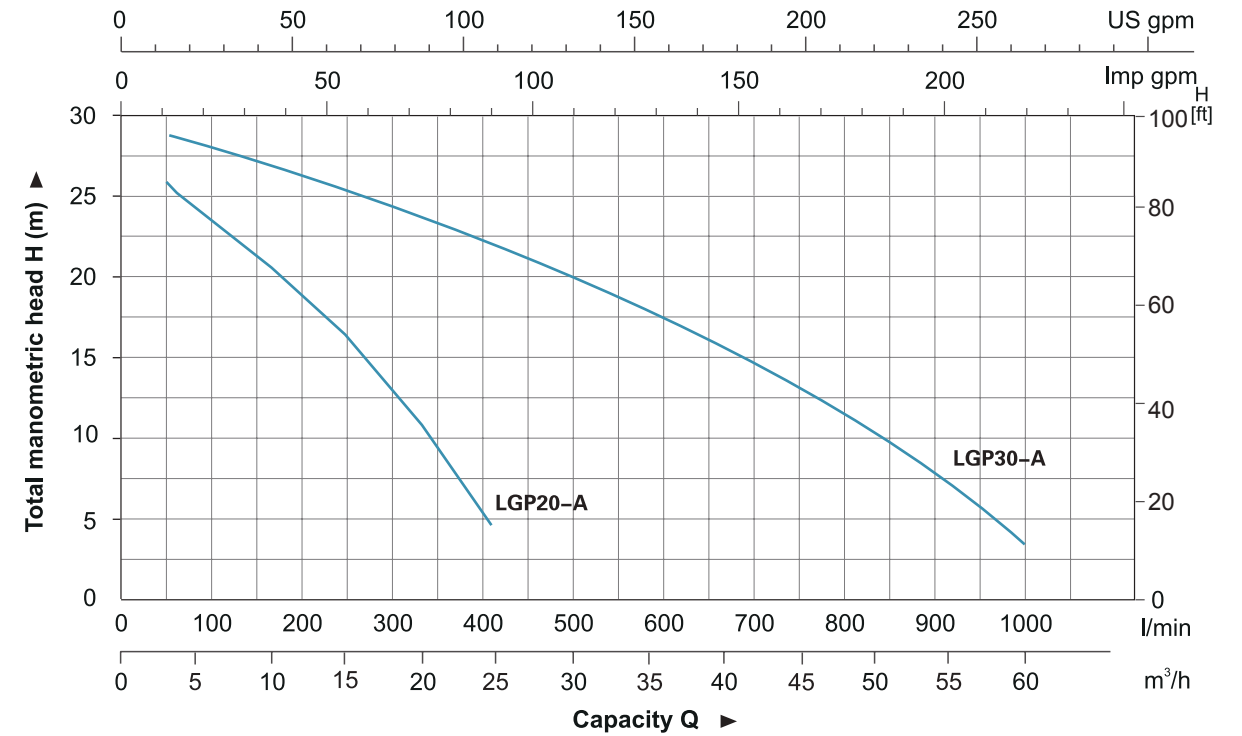

### Materials Table

No.	Part	Material
1	Frame	Steel
2	Gasoline engine	
3	Pump cover	ADC12
4	O-ring	NBR
5	Mechanical seal	Carbon/Ceramic
6	Impeller	Cast iron
7	Diffuser	Cast iron
8	O-ring	NBR
9	Pump body	Aluminum
10	Gasket	NBR
11	Outlet	Aluminum
12	Filling plug	PA6
13	Non-return valve	NBR
14	Inlet	Aluminum

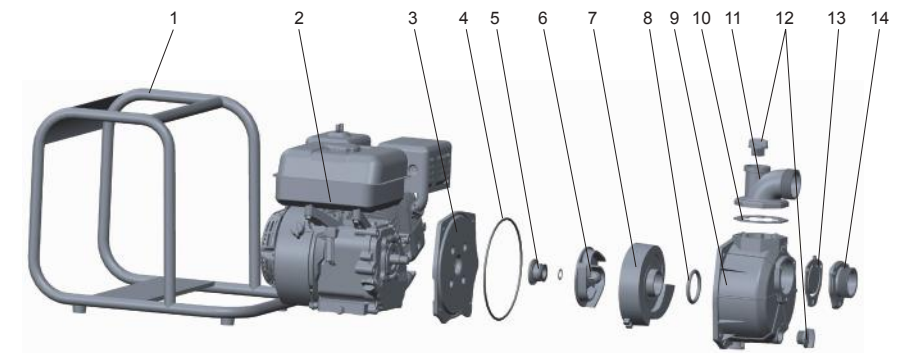

### Package Information

Model	GW (Kgs)	L (mm)	W (mm)	H (mm)	Quantity (PCS/20 TEU)
LGP20-A	21.5	470	412	432	340
LGP30-A	23	470	412	432	340





### Application

- To transfer clean water with liquid temperature between 0 and 40
- Application in water supply and drainage for factories, mines, municipal facilities as well as field irrigation, etc.

### Features

- Strengthened pump body ensures more durable and reliable service
- Better sealing effect by using special mechanical seal
- Multiple direction outlet for convenient use
- Improved starter handle for easier starting
- 20% increased loading quantity thanks to new frame structure
- Less gasoline consumption
- Powerful, durable LEO engine

### Pump

- Anti-rust cast iron impeller and diffuser
- High quality forged steel crankshaft
- Max.Suction: 8 m , Suck 5 m needs 120 s
- Inlet/outlet: 50 mm/80 mm

### Engine

- Single cylinder, 4-stroke, Air-cooled
- Max.power: 6.5 HP
- Rated speed: 3600 rpm
- Reliable engine equipped with low engine oil shut off system

### Identification Codes

**LGP 20 - C**

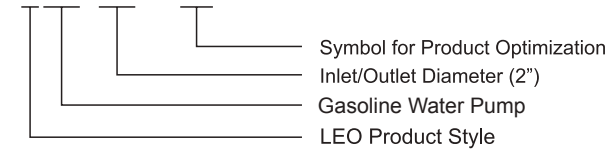

### Technical Data

Model	Power HP	Fuel tank L	Engine Oil L	Displacement cc	Engine	Q (m³/h)																
						0	5	10	15	20	25	30	35	40	45	50	55	60				
LGP20-C	6.5	2.8	0.55	196	G200	30	28	24.5	21	16	10.5	3.5	-	-	-	-	-	-	-	-	-	-
LGP30-C	6.5	2.8	0.55	196	G200	30	29	27.5	26	24	21.7	19.5	16.9	14.4	11.6	9.2	6.4	3.5	-	-	-	-

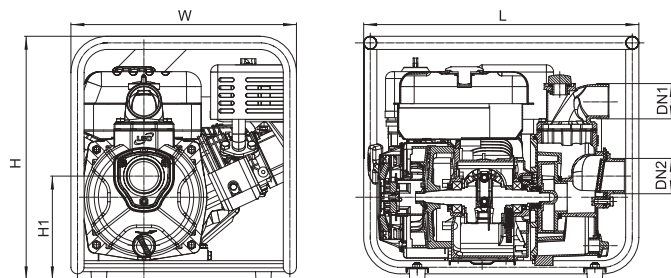

### Dimension

Model	DN1	DN2	L (mm)	W (mm)	H (mm)	H1 (mm)
LGP20-C	2"	2"	460	375	403.5	181
LGP30-C	3"	3"	500	375	425.5	189

### Hydraulic Performance Curves

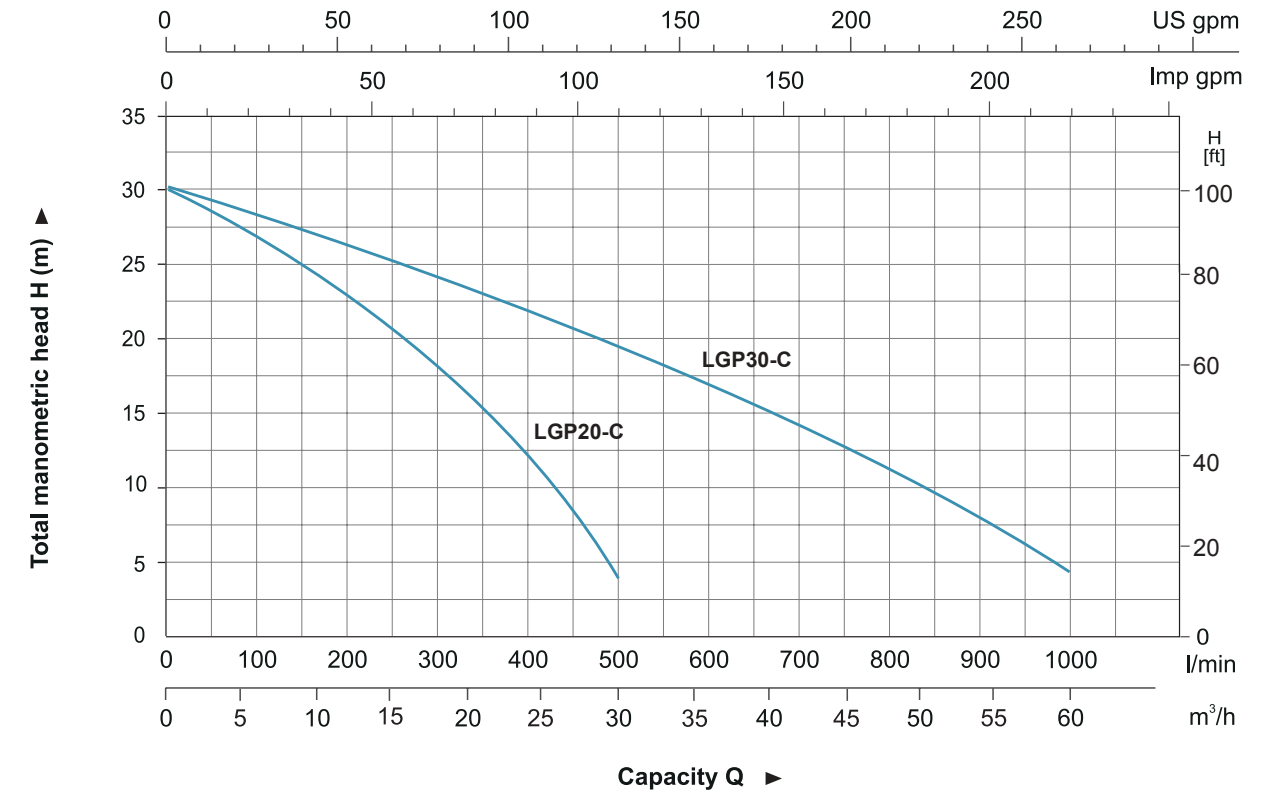

### Materials Table

No.	Part	Material
1	Frame	Steel
2	Gasoline engine	
3	Pump cover	ADC12
4	O-ring	NBR
5	Mechanical seal	Carbon/Ceramic
6	Impeller	Cast iron
7	Diffuser	Cast iron
8	O-ring	NBR
9	Pump body	Aluminum
10	Gasket	NBR
11	Outlet	Aluminum
12	Filling plug	PA6
13	Non-return valve	NBR
14	Inlet	Aluminum

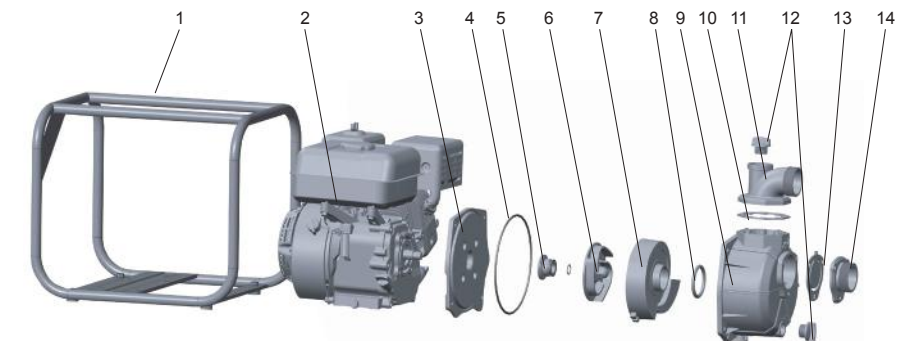

### Package Information

Model	GW (Kgs)	L (mm)	W (mm)	H (mm)	Quantity (PCS/20 TEU)
LGP20-C	21.5	475	390	425	365
LGP30-C	23	515	390	447	335





### Application

- To transfer clean water with liquid temperature between 0 and 40
- Application in water supply and drainage for factories, mines, municipal facilities as well as field irrigation, etc.

### Features

- Flexible multi-directional discharge
- Durable steel frame
- Compact for easy carrying
- Quiet and reliable engine
- Low emission and fuel consumption

### Pump

- Cast iron impeller and cast aluminum housing for long life time
- Max. suction: 8 m, suck 5 m needs 120 s
- Inlet/outlet: 100 mm

### Engine

- Single cylinder, 4-stroke, Air-cooled
- Max. power: 6.5 HP
- Rated speed: 3600 rpm
- Reliable engine equipped with low engine oil shut off system

### Identification Codes

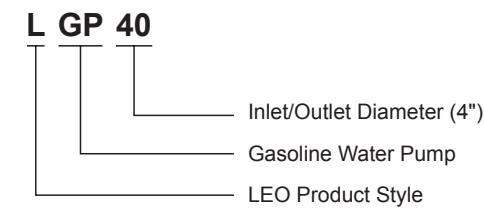

### Technical Data

Model	Power HP	Fuel tank L	Engine Oil L	Displacement cc	Engine	Capacity Q								
						Q (m³/h)	Q (l/min)	0	10	20	30	40	50	60
LGP40	6.5	2.8	0.55	196	G200	<b>H(m)</b>	30	26	22.6	20.1	17.1	13.3	9	3.1

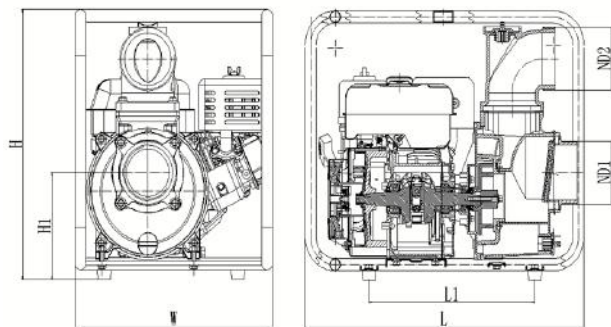

### Dimension

Model	DN1	DN2	L (mm)	W (mm)	H (mm)	H1 (mm)	L1 (mm)
LGP40	4"	4"	555	393	479	190	330

### Hydraulic Performance Curves

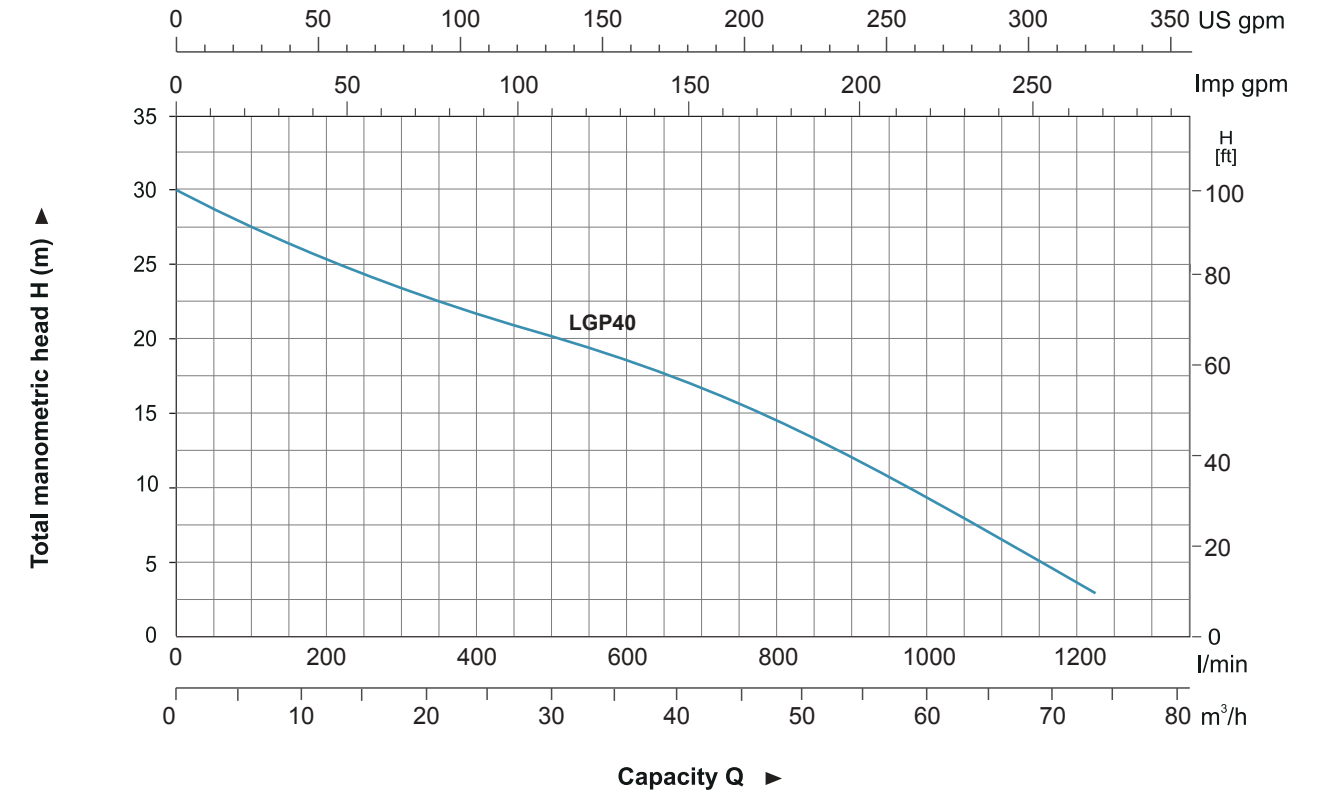

### Materials Table

No.	Part	Material
1	Frame	Steel
2	Gasoline engine	
3	Pump cover	ADC12
4	O-ring	NBR
5	Mechanical seal	Carbon/Ceramic
6	Impeller	Cast iron
7	Diffuser	Cast iron
8	O-ring	NBR
9	Pump body	Aluminum
10	Gasket	NBR
11	Outlet	Aluminum
12	Filling plug	PA6
13	Non-return valve	NBR
14	Inlet	Aluminum

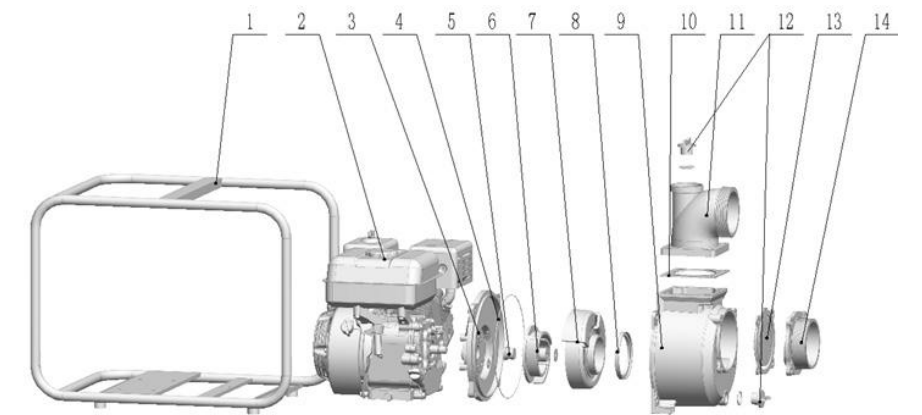

### Package Information

Model	GW (Kgs)	L (mm)	W (mm)	H (mm)	Quantity (PCS/20 TEU)
LGP40	24.3	570	400	490	232







### Application

- To transfer clean water with liquid temperature between 0 and 40
- Application in water supply and drainage for factories, mines, municipal facilities as well as field irrigation, etc.

### Features

- Strengthened pump body ensures more durable and reliable service
- Better sealing effect by using special mechanical seal
- 5-direction outlet for convenient use
- Improved starter handle for easier starting
- 20% increased loading quantity thanks to very compact design
- Less gasoline consumption

### Pump

- Anti-rust cast iron impeller and diffuser
- High quality forged steel crankshaft
- Max.Suction: 8 m , Suck 5 m needs 120 s
- Inlet/outlet: 50 mm/80 mm

### Engine

- Single cylinder, 4-stroke, Air-cooled
- Max.power: 5 HP
- Rated speed: 3600 rpm
- Reliable engine equipped with low engine oil shut off system

### Identification Codes

**L GP 20 - B (2B)**

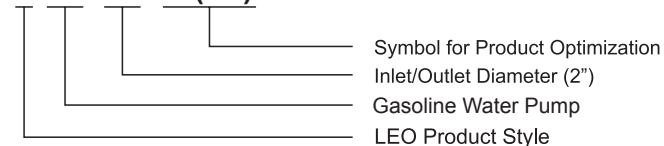

### Technical Data

Model	Power HP	Fuel tank L	Engine Oil L	Displacement cc	Engine	Q (m³/h)															
						0	5	10	15	20	25	30	35	40	45	50	55	60			
LGP20-B	5	2.8	0.58	163	GX160	30	28.5	25	22	18	14	7.5	-	-	-	-	-	-			
LGP20-2B	5	3.1	0.6	163	XR750	30	28.5	25	22	18	14	7.5	-	-	-	-	-	-			
LGP30-B	5	2.8	0.58	163	GX160	30	28.4	27.5	26	24.8	21	19	16.8	14.9	11	9.9	6	5			
LGP30-2B	5	3.1	0.6	163	XR750	30	28.4	27.5	26	24.8	21	19	16.8	14.9	11	9.9	6	5			

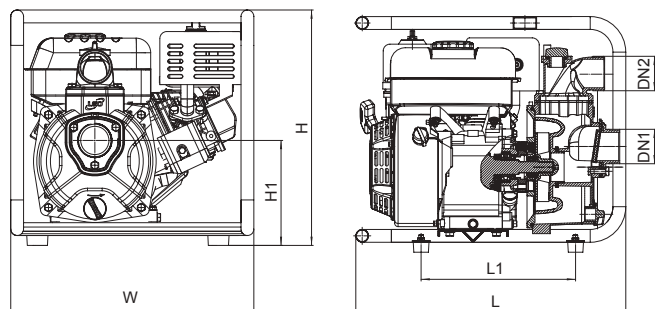

### Dimension

Model	DN1	DN2	L (mm)	W (mm)	H (mm)	H1 (mm)
LGP20-B	2"	2"	530	420	425	181
LGP30-B	3"	3"	530	420	425	190.5
LGP20-2B	2"	2"	530	420	425	183
LGP30-2B	3"	3"	530	420	425	190

### Hydraulic Performance Curves

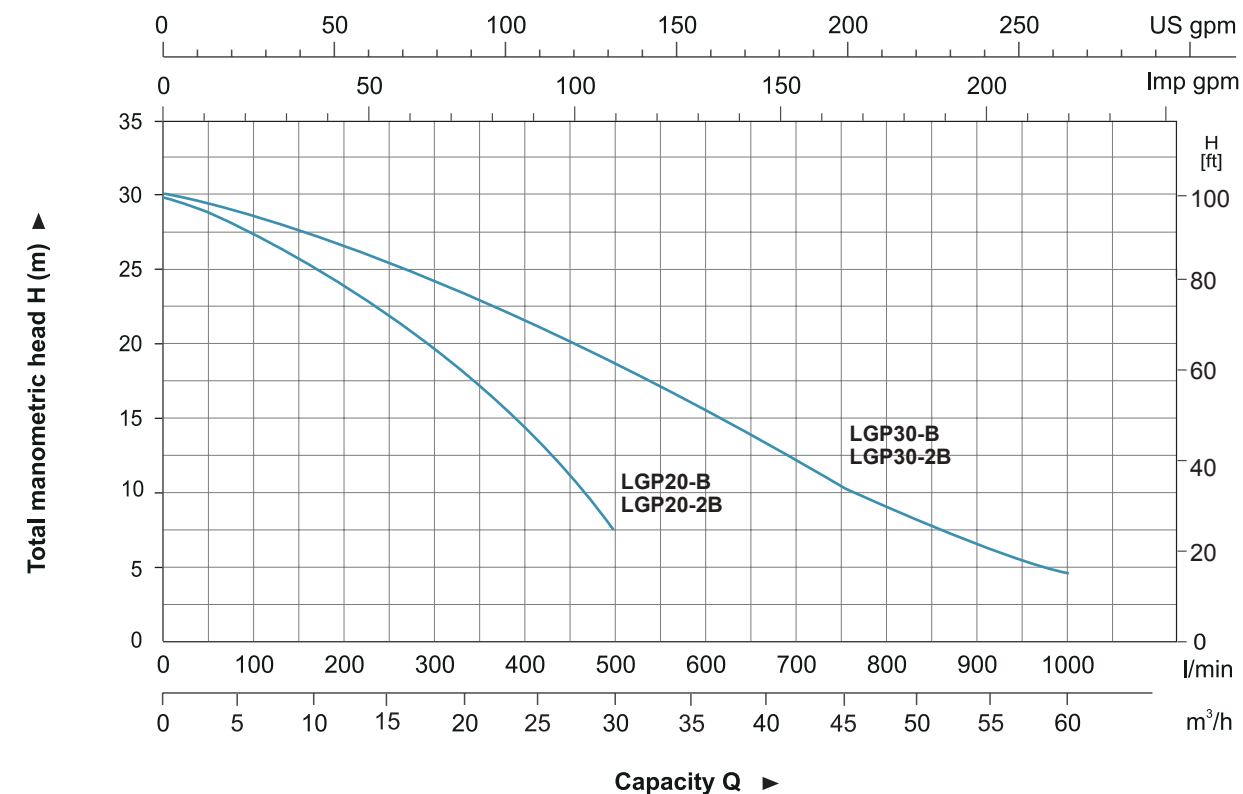

### Materials Table

No.	Part	Material
1	Frame	Steel
2	Gasoline engine	
3	Pump cover	ADC12
4	Mechanical seal	Carbon/Ceramic
5	O-ring	NBR
6	Impeller	Cast iron
7	Diffuser	Cast iron
8	O-ring	NBR
9	Pump body	Aluminum
10	Gasket	NBR
11	Outlet	Aluminum
12	Filling plug	PA6
13	Non-return valve	NBR
14	Inlet	Aluminum

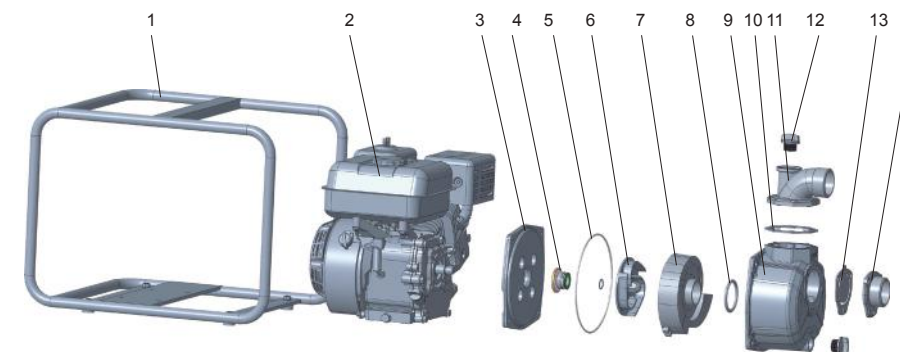

### Package Information

Model	GW (Kgs)	L (mm)	W (mm)	H (mm)	Quantity (PCS/20 TEU)
LGP20-B	24	545	435	435	245
LGP30-B	25	545	435	435	245
LGP20-2B	25.2	545	435	435	245
LGP30-2B	27.2	545	435	435	245





### Application

- To transfer clean water with liquid temperature between 0 and 40
- Application in water supply and drainage for factories, mines, municipal facilities as well as field irrigation, etc.
- Suitable for longer distance and greater height water transfer

### Features

- New unique design with ergonomic feature
- Portable and compact pump frame
- High quality motor with excellent performance and long service life
- Impeller designed with high efficient hydraulic system
- Low fuel consumption
- LEO engine as default, BS/Honda engine is optional

### Pump

- Anti-rust cast iron diffuser
- Max.Suction: 8 m , Suck 5 m needs 120 s
- Inlet/outlet: 50 mm/2 x 38 mm+1 x 50 mm  
38 mm/1 x 38 mm+2 x 25 mm

### Engine

- Single cylinder, 4-stroke, Air-cooled
- Max.power: 6.5 HP
- Rated speed: 3600 rpm
- Reliable engine equipped with low engine oil shut off system

### Identification Codes

**LGP 20 - H(G,2G,3G,4G)**

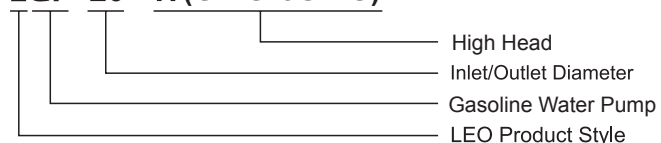

### Technical Data

Model	Power HP	Fuel tank L	Engine Oil L	Displacement cc	Engine	Q (m³/h)								
						0	5	10	15	20	25	30		
LGP20-H	6.5	2.8	0.55	196	G200	55	52.4	47.8	40.6	30.4	20	5		
LGP20-G	6.5	2.8	0.58	196	GX200	55	52.4	47.8	40.6	30.4	20	5		
LGP20-2H	6.5	2.8	0.55	196	G200	80	72.5	60	45	5	-	-		
LGP20-2G	6.5	2.8	0.58	196	GX200	80	72.5	60	45	5	-	-		
LGP20-3G	6.5	3.1	0.6	208	XR950	60	55.2	50	42.8	15	-	-		
LGP20-4G	6.5	3.1	0.6	208	XR950	80	77.6	60.7	40	4.4	-	-		

### Hydraulic Performance Curves

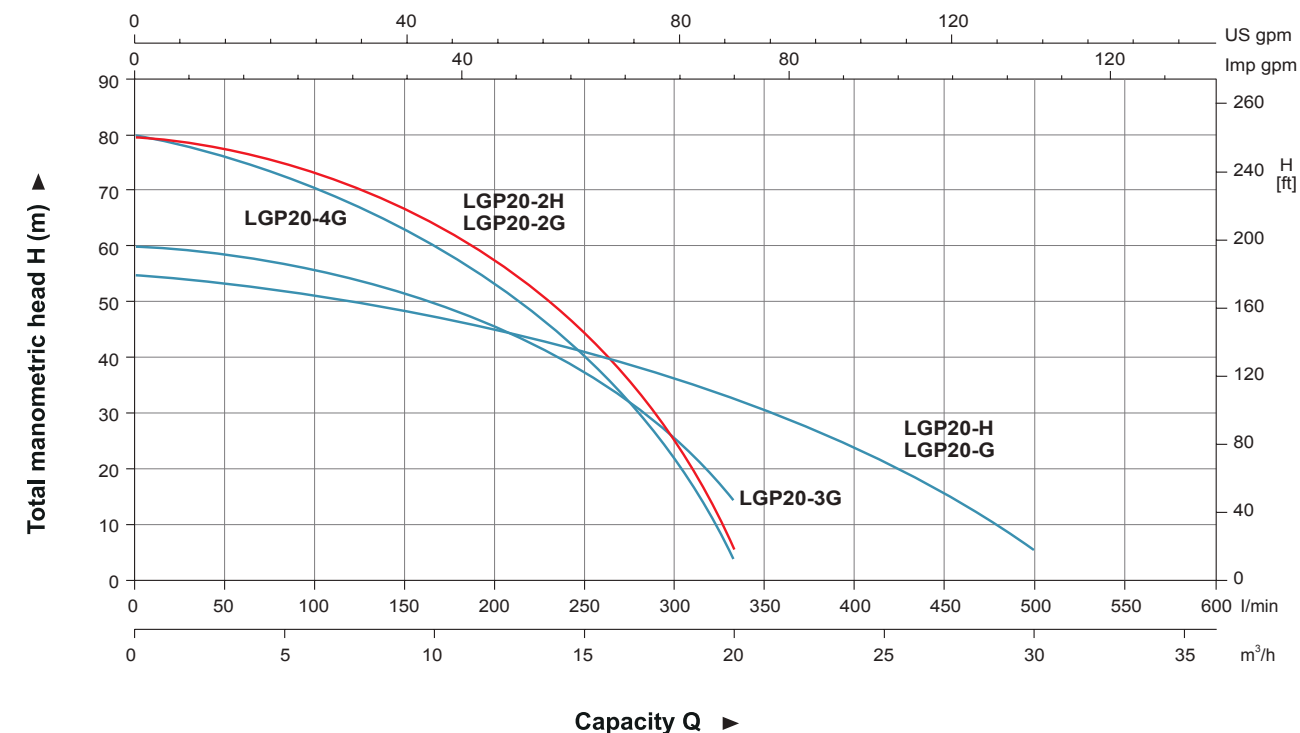

### Materials Table

No.	Part	Material
1	Frame	Steel
2	Engine	
3	Bracket	Aluminum
4	Mechanical seal	Carbon/Ceramic
5	O-ring	NBR
6	Impeller	Aluminum
7	Seal ring	NBR
8	Diffuser	HT200
9	Seal ring	NBR
10	Pipe blanking cap	PP
11	Seal ring	NBR
12	Outlet	Aluminum
13	Gasket	NBR
14	Pump body	Aluminum
15	Non-return valve	NBR
16	Inlet	Aluminum
17	Filling plug	PA6

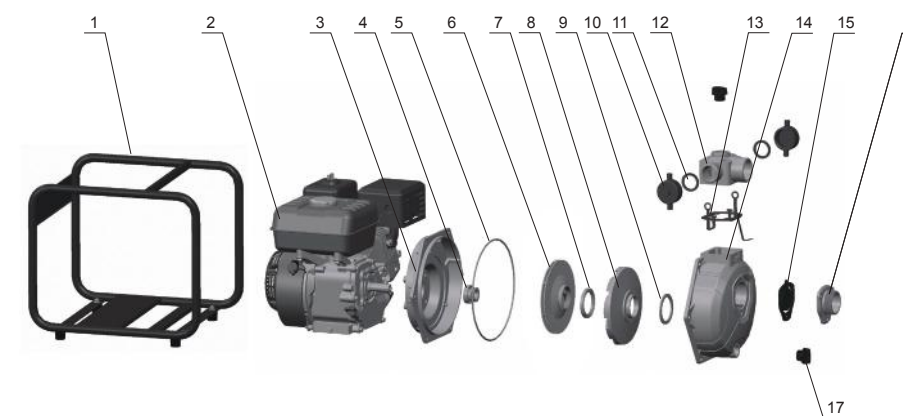

### Dimension

Model	DN1	DN2	2×DN3	L (mm)	W (mm)	H (mm)	H1 (mm)
LGP20-H	2"	2"	1.5"	463	398	406	200
LGP20-G	2"	2"	1.5"	530	420	425	192.2
LGP20-2H	2"	2"	1.5"	463	398	406	200
LGP20-2G	2"	2"	1.5"	530	420	425	192.2
LGP20-3G	2"	2"	1.5"	530	420	425	190
LGP20-4G	2"	2"	1.5"	530	420	425	190

### Package Information

Model	GW (Kgs)	L (mm)	W (mm)	H (mm)	Quantity (PCS/20 TEU)
LGP20-H	23.22	470	412	432	305
LGP20-G	25.5	545	435	465	196
LGP20-2H	23.24	470	412	432	305
LGP20-2G	27	545	435	465	196
LGP20-3G	27.2	545	435	465	196
LGP20-4G	28.2	545	435	465	196

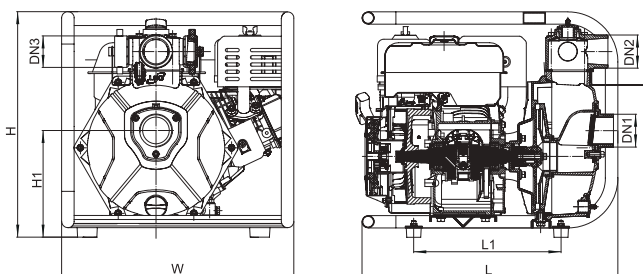





### Application

- To transfer clean water with liquid temperature between 0 and 40
- Application in water supply and drainage for factories, mines, municipal facilities as well as field irrigation, etc.

### Features

- Strengthened cast-iron pump body ensures more durable and reliable service
- Impeller designed with high efficient hydraulic system
- High quality engine with excellent performance and long service life
- Better sealing effect by using special mechanical seal
- Low fuel consumption

### Pump

- Anti -rust cast iron pump body
- Aluminum alloy impeller
- Max.Suction: 8 m , Suck 5 m needs 120 s
- Inlet/outlet: 50 mm

### Engine

- Single cylinder, 4-stroke, Air-cooled
- Max.power: 6.5 HP
- Rated speed: 3600 rpm
- Reliable engine equipped with low engine oil shut off system

### Identification Codes

L GP 20 i - A

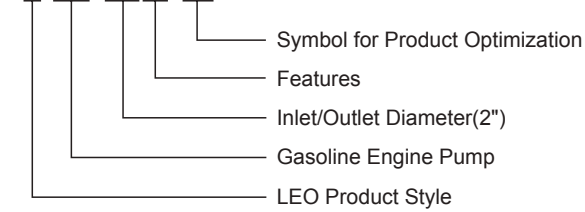

### Technical Data

Model	Power	Fuel tank	Engine Oil	Displacement	Engine	Q (m³/h)							
	HP	L	L	cc		0	5	10	15	20	25	28	
LGP20i-A	6.5	2.8	0.55	196	G200	H (m)	50	48	46	40	28	11.5	5

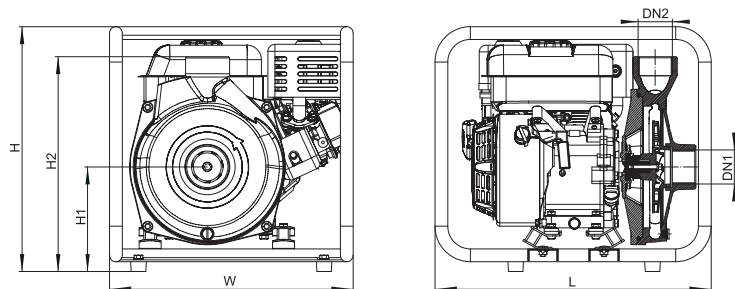

### Dimension

Model	DN1	DN2	L (mm)	W (mm)	H (mm)	H1 (mm)	H2 (mm)
LGP20i-A	2"	2"	476	420	440	180	370

### Hydraulic Performance Curves

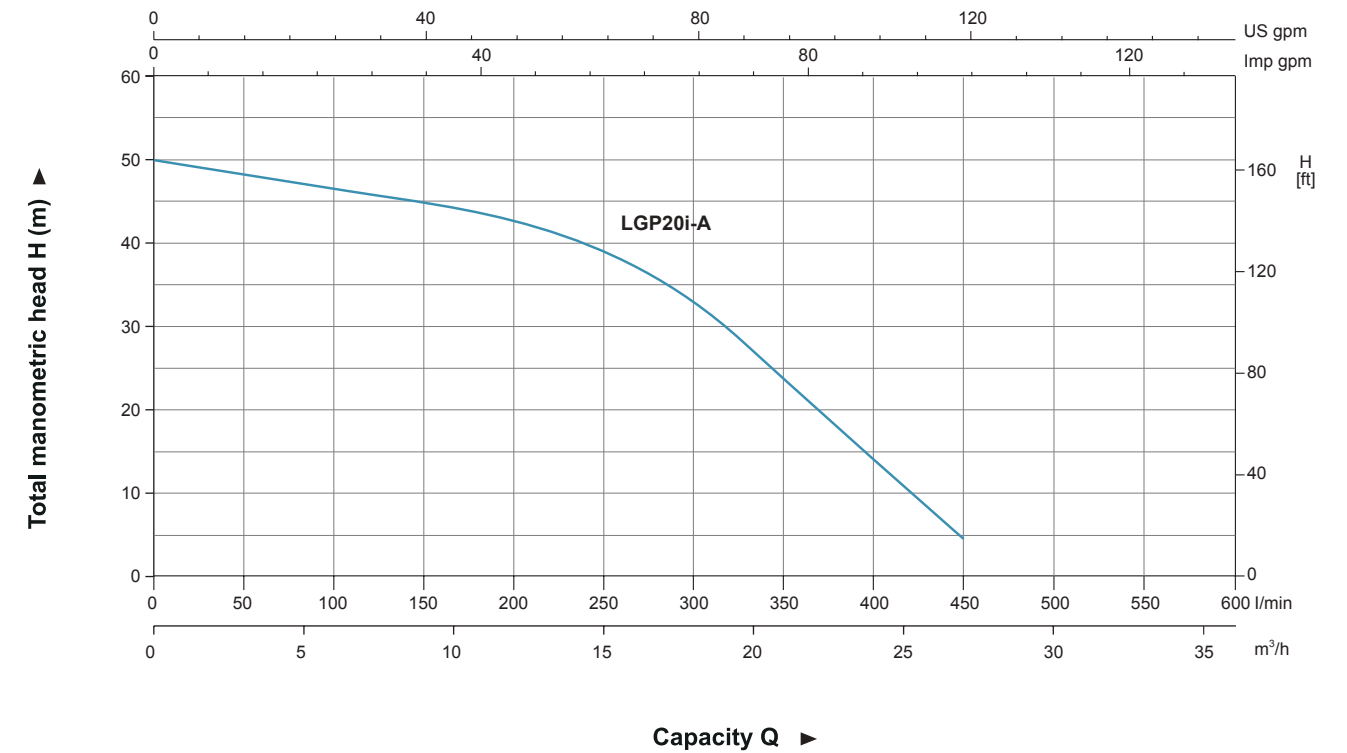

### Materials Table

No.	Part	Material
1	Frame	Steel
2	Engine	
3	Pump cover	HT200
4	O-ring	NBR
5	Mechanical seal	Carbon/Ceramic
6	Impeller	Aluminum
7	Pump body	HT200
8	Plug	HPb59-1
9	O-ring	NBR
10	Plug	HPb59-1

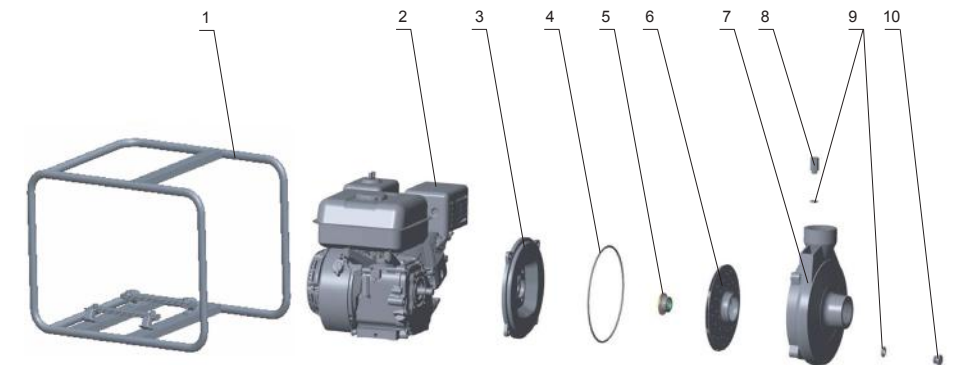

### Package Information

Model	GW (Kgs)	L (mm)	W (mm)	H (mm)	Quantity (PCS/20 TEU)
LGP20i-A	30	470	433	450	325





### Application

- To transfer clean water or trash water with liquid temperature between 0 and 40
- Application in water supply and drainage for factories, mines, municipal facilities as well as field irrigation, etc.

### Features

- Strengthened aluminium alloy pump body ensures more durable and reliable service
- Original design of the pump body for easy cleanout
- Impeller designed with high efficient hydraulic system
- Honda engine with excellent performance and long service life
- Better sealing effect by using special mechanical seal
- Low fuel consumption
- Honda Engine

### Pump

- Aluminum alloy pump body
- Anti -rust cast iron impeller
- Max. suction: 8 m
- Rated suction: 5 m / 120 s
- Inlet/outlet: 50 mm / 50 mm , 80 mm / 80 mm
- Max.diameter of particle: 22 mm
- Liquid temperature range: 0 ~ 40

### Engine

- Single cylinder,4-stroke, Air-cooled
- Max.power: 9 HP
- Displacement: 163 cc , 270 cc
- Rated speed: 3600 rpm

### Identification Codes

#### L GP 20 - T

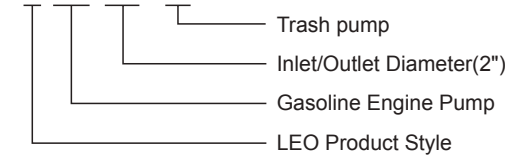

### Technical Data

Model	Power HP	Fuel tank L	Engine Oil L	Displacement cc	Engine	Q (m³/h)																
						0	5	10	15	20	25	30	35	40	45	55	65	75				
LGP20-T	5	2.8	0.55	163	GX160	25	24.1	22.5	20.6	18.6	16.1	13.5	10	6	-	-	-	-				
LGP30-T	9	3.2	1.1	270	GX270	25	24	23	21	19	18	16	15	14	12	9	6	2				

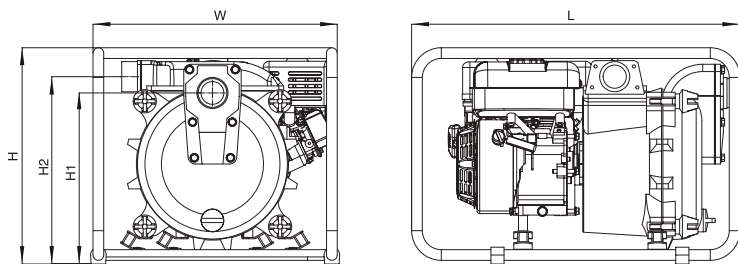

### Dimension

Model	DN1	DN2	L (mm)	W (mm)	H (mm)	H1 (mm)	H2 (mm)
LGP20-T	2"	2"	675	502	446	350	385
LGP30-T	3"	3"	715	502	532.5	380	415

### Hydraulic Performance Curves

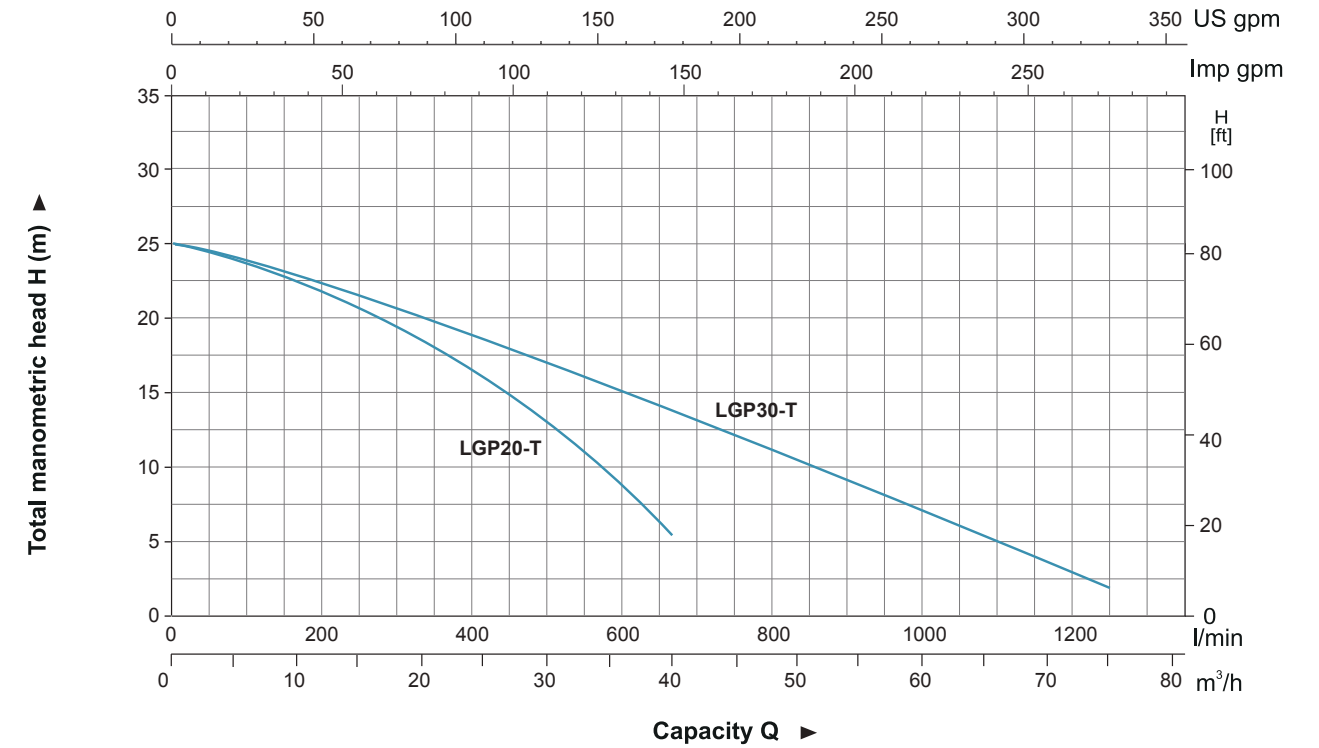

### Materials Table

No.	Part	Material
1	Frame	Steel
2	Engine	
3	Outlet	Aluminum
4	Seal	NBR
5	Outlet cover	Aluminum
6	O-ring	NBR
7	Plug	
8	O-ring	NBR
9	Pump cover	Aluminum
10	O-ring	NBR
11	Mechanical seal	
12	Plug	
13	Impeller	HT200
14	O-ring	NBR
15	Diffuser	HT200
16	O-ring	NBR
17	O-ring	NBR
18	Pump body	Aluminum
19	Seal	
20	Inlet	Aluminum

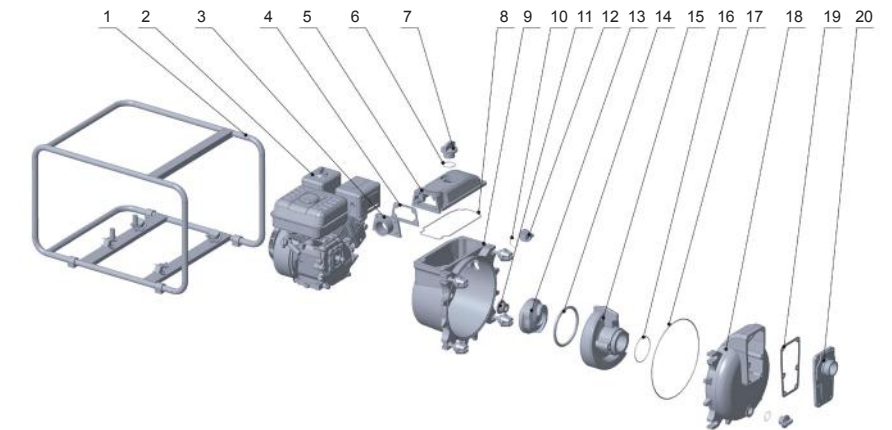

### Package Information

Model	GW (Kgs)	L (mm)	W (mm)	H (mm)
LGP20-T	48.8	675	502	446
LGP30-T	63	745	542	582





### Application

- Can be used to transfer slurry, liquids that containing mud, sand, small rocks and other debris diameter less than 22mm.
- Sewage treatment for civil engineering, mines, quarries and municipal facilities, etc.
- Water supply and drainage for factories, mines, municipal facilities as well as field irrigation, etc.

### Features

- All new design with ergonomic feature
- Reliable 4-stroke gasoline engine with low fuel consumption and high quality crankshaft
- Portable, durable and compact pump frame
- Durable sealing system with special mechanical seal
- Silicon carbide mechanical seal for increased abrasive resistance, longer life and less maintenance
- Pump body can easily disassembled and assembled for cleaning out debris, or pump repair

### Pump

- Anti-rust cast iron impeller and diffuser
- Max. Suction: 8 m, Suck 5 m needs 120 s
- Inlet/outlet: 3"
- Max. diameter of particle: 22 mm
- Liquid temperature range: 0 ~ 40

### Engine

- Single cylinder, 4-stroke, Air-cooled
- Max. power: 6.5 HP
- Rated speed: 3600 rpm
- Reliable engine equipped with low engine oil shut off system

### Identification Codes

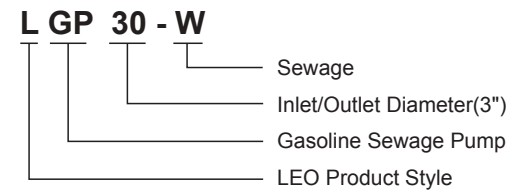

### Technical Data

Model	Power HP	Fuel tank L	Engine Oil L	Displacement cc	Engine	Q (m³/h)															
						0	5	10	15	20	25	30	35	40	45	50	55	60			
LGP30-W	6.5	2.8	0.55	196	G200	<b>H(m)</b>	30	27	25.5	24	22	20.5	18.5	17	15.5	14.5	11.5	9.2	7		

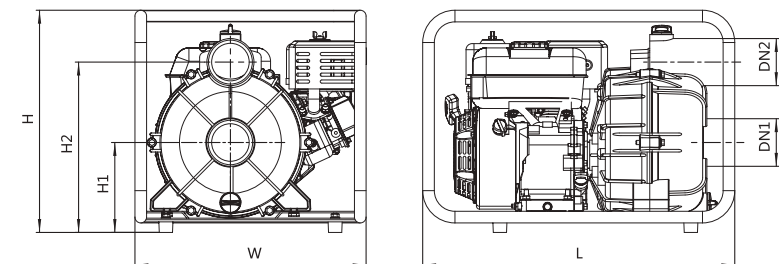

### Dimension

Model	DN1	DN2	L (mm)	W (mm)	H (mm)	H1 (mm)	H2 (mm)
LGP30-W	3"	3"	590	437	431	195	347

### Hydraulic Performance Curves

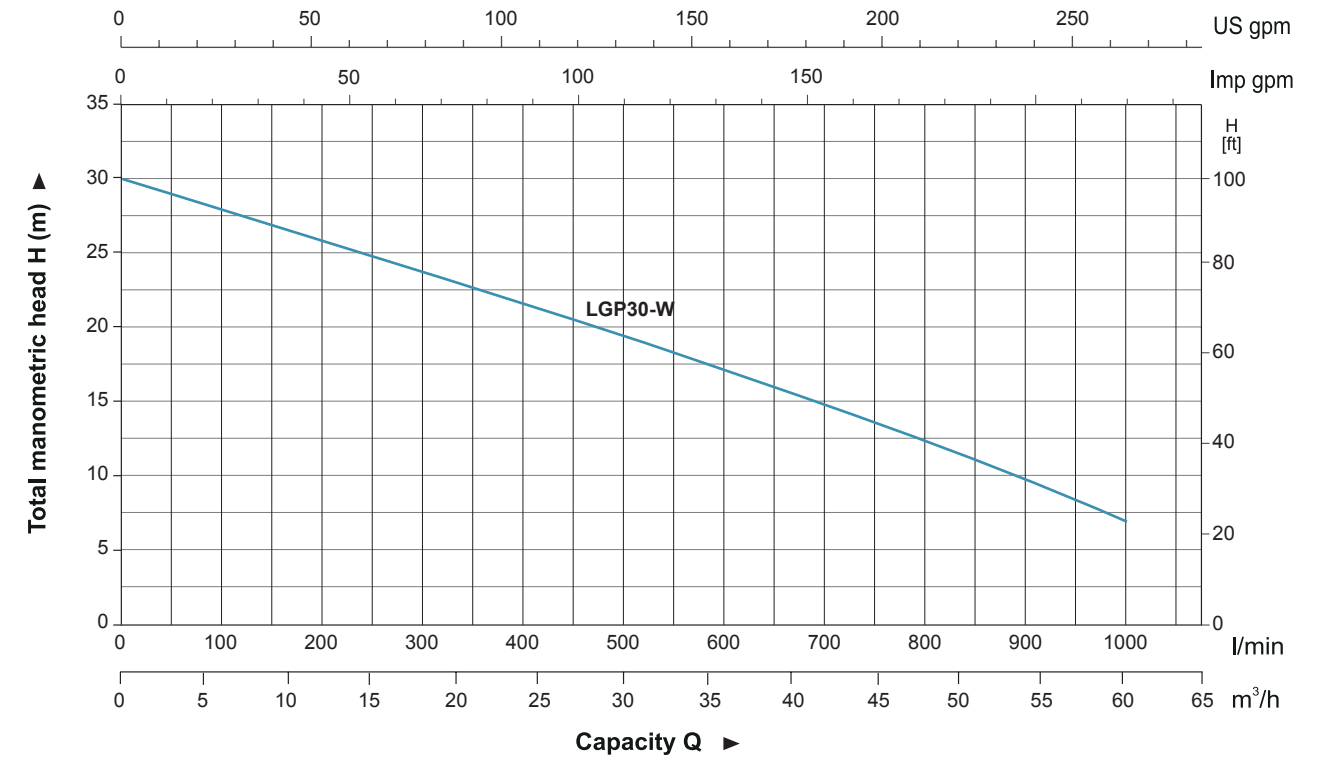

### Materials Table

No.	Part	Material
1	Frame	Steel
2	Engine	
3	Pump cover	Aluminum
4	O-ring	NBR
5	Mechanical seal	Silicon carbide / Silicon carbide
6	Impeller	HT200
7	O-ring	NBR
8	Diffuser	HT200
9	Non-return valve	NBR
10	Pump body	Aluminum
11	Plug	ABS

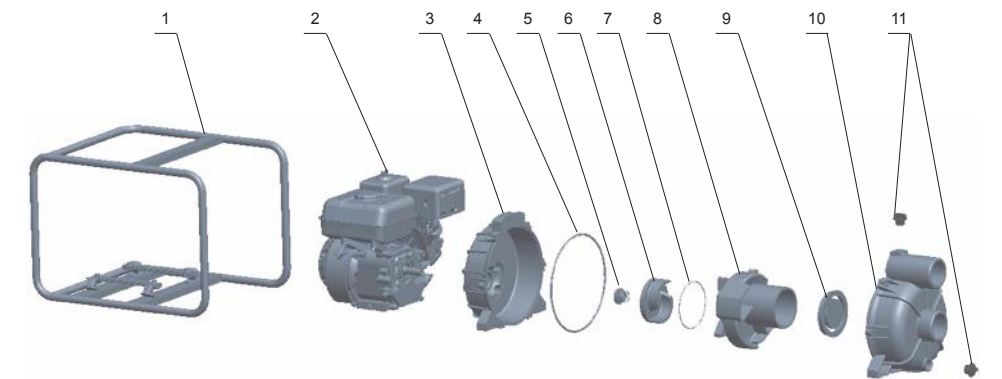

### Package Information

Model	GW (Kgs)	L (mm)	W (mm)	H (mm)	Quantity (PCS/20 TEU)
LGP30-W	34.6	605	450	459	168

